

HOW TO USE THIS MANUAL

GENERAL INFORMATION

IND00-81

1. INDEX

An INDEX is provided on the first page of each section to guide you to the item to be repaired. To assist you in finding your way through the manual, the Section Title and major heading are given at the top of every page.

2. PRECAUTION

At the beginning of each section, a PRECAUTION is given that pertains to all repair operations contained in that section.

Read these precautions before starting any repair task.

3. TROUBLESHOOTING

TROUBLESHOOTING tables are included for each system to help you diagnose the problem and find the cause. The fundamentals of how to proceed with troubleshooting are described on [page IN-27](#).

Be sure to read this before performing troubleshooting.

4. PREPARATION

Preparation lists the SST (Special Service Tools), recommended tools, equipment, lubricant and SSM (Special Service Materials) which should be prepared before beginning the operation and explains the purpose of each one.

5. REPAIR PROCEDURES

Most repair operations begin with an overview illustration. It identifies the components and shows how the parts fit together.

Example:

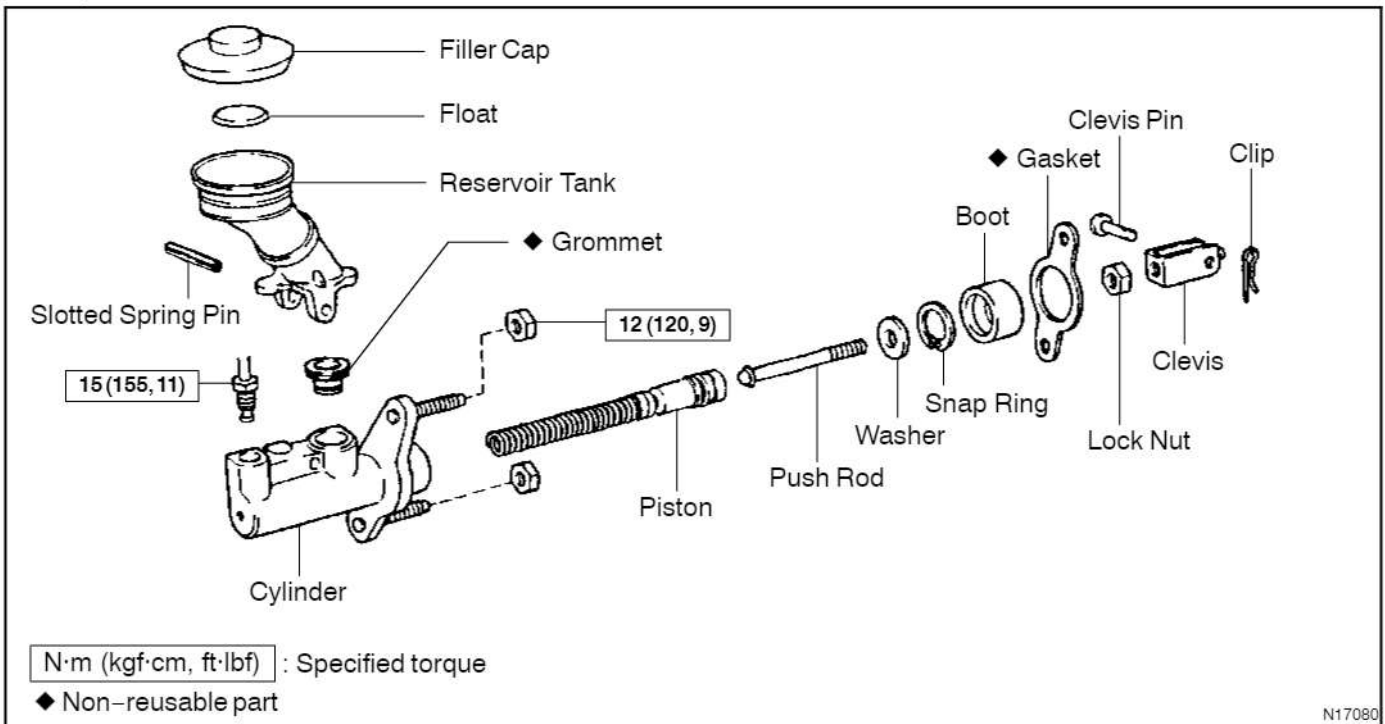

The procedures are presented in a step-by-step format:

- The illustration shows what to do and where to do it.
- The task heading tells what to do.
- The detailed text tells how to perform the task and gives other information such as specifications and warnings.

Example:

Task heading: what to do



21. CHECK PISTON STROKE OF OVERDRIVE BRAKE

- (a) Place SST and a dial indicator onto the overdrive brake piston as shown in the illustration.

SST 09350-30020 (09350-06120)

Set part No.

Component part No.

Detailed text: how to do task

- (b) Measure the stroke applying and releasing the compressed air (392 — 785 kPa, 4 — 8 kgf/cm² or 57 — 114 psi) as shown in the illustration.

Piston stroke: 1.40 — 1.70 mm (0.0551 — 0.0669 in.)

Specification

This format provides the experienced technician with a FAST TRACK to the information needed. The upper case task heading can be read at a glance when necessary, and the text below it provides detailed information. Important specifications and warnings always stand out in bold type.

6. REFERENCES

References have been kept to a minimum. However, when they are required you are given the page to refer to.

7. SPECIFICATIONS

Specifications are presented in bold type throughout the text where needed. You never have to leave the procedure to look up your specifications. They are also found in Service Specifications section for quick reference.

8. CAUTIONS, NOTICES, HINTS:

- CAUTIONS are presented in bold type, and indicate there is a possibility of injury to you or other people.
- NOTICES are also presented in bold type, and indicate the possibility of damage to the components being repaired.
- HINTS are separated from the text but do not appear in bold. They provide additional information to help you perform the repair efficiently.

9. SI UNIT

The UNITS given in this manual are primarily expressed according to the SI UNIT (International System of Unit), and alternately expressed in the metric system and in the English System.

Example:

Torque: 30 N·m (310 kgf·cm, 22 ft·lbf)

IDENTIFICATION INFORMATION

VEHICLE IDENTIFICATION AND ENGINE SERIAL NUMBER

IN08Y-05

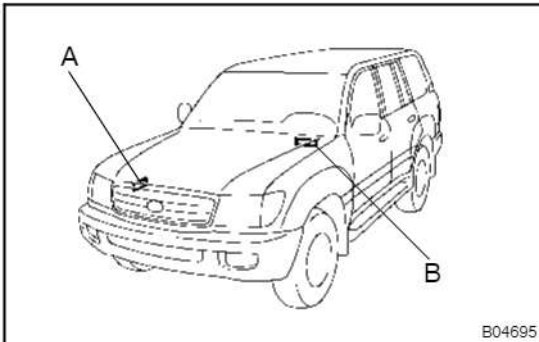

1. VEHICLE IDENTIFICATION NUMBER

The vehicle identification number is stamped on the outer surface of the front right side frame. This number is also stamped on the manufacturer's plate.

A: Vehicle Identification Number

B: Manufacturer's Plate

1FZ-FE Engine:

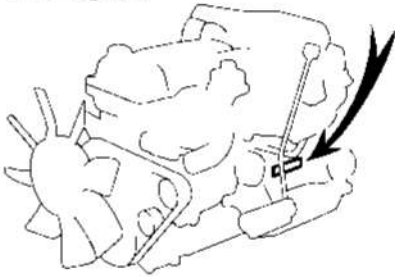

1HZ and 1HD-FTE Engine:

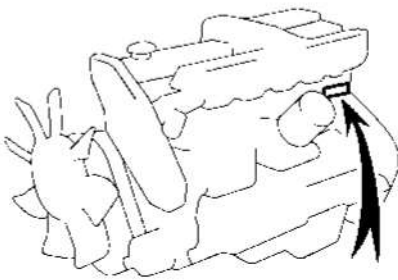

2UZ-FE Engine:

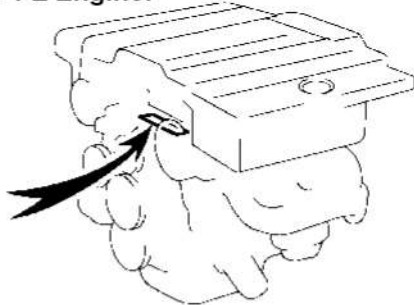

B04691

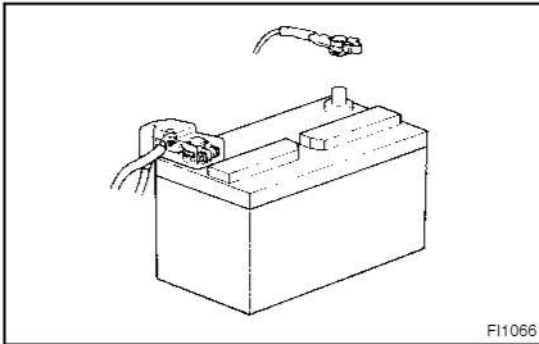

REPAIR INSTRUCTIONS

GENERAL INFORMATION

IN08T-06

BASIC REPAIR HINT

- (a) Use fender, seat and floor covers to keep the vehicle clean and prevent damage.
- (b) During disassembly, keep parts in the appropriate order to facilitate reassembly.
- (c) Installation and removal of battery terminal:
 - (1) Before performing electrical work, disconnect the negative (-) terminal cable from the battery.
 - (2) If it is necessary to disconnect the battery for inspection or repair, first disconnect the negative (-) terminal cable.
 - (3) When disconnecting the terminal cable to prevent damage to battery terminal, loosen the cable nut and raise the cable straight up without twisting or prying it.
 - (4) Clean the battery terminals and cable ends with a clean shop rag. Do not scrape them with a file or other abrasive objects.
 - (5) Install the cable ends to the battery terminals after loosening the nut, and tighten the nut after installation. Do not use a hammer to tap the cable ends onto the terminals.
 - (6) Be sure the cover for the positive (+) terminal is properly in place.
- (d) Check hose and wiring connectors to make sure that they are connected securely and correctly.
- (e) Non-reusable parts
 - (1) Always replace cotter pins, gaskets, O-rings, oil seals, etc. with new ones.
 - (2) Non-reusable parts are indicated in the component illustrations by the "◆" symbol.

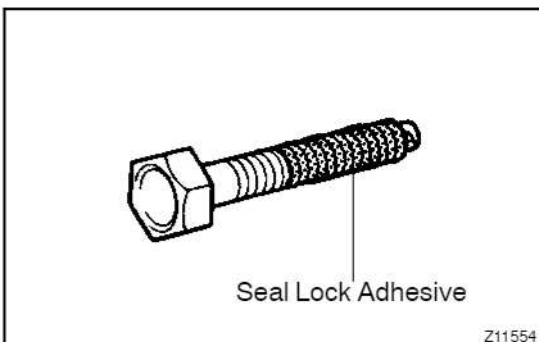

- (f) Precoated parts
Precoated parts are bolts, nuts, etc. that are coated with a seal lock adhesive at the factory.
 - (1) If a precoated part is retightened, loosened or caused to move in any way, it must be recoated with the specified adhesive.
 - (2) When reusing precoated parts, clean off the old adhesive and dry with compressed air. Then apply the specified seal lock adhesive to the bolt, nut or threads.

- (3) Precoated parts are indicated in the component illustrations by the "★" symbol.
- (g) When necessary, use a sealer on gaskets to prevent leaks.
- (h) Carefully observe all specifications for bolt tightening torques. Always use a torque wrench.
- (i) Use of special service tools (SST) and special service materials (SSM) may be required, depending on the nature of the repair. Be sure to use SST and SSM where specified and follow the proper work procedure. A list of SST and SSM can be found in Preparation section in this manual.

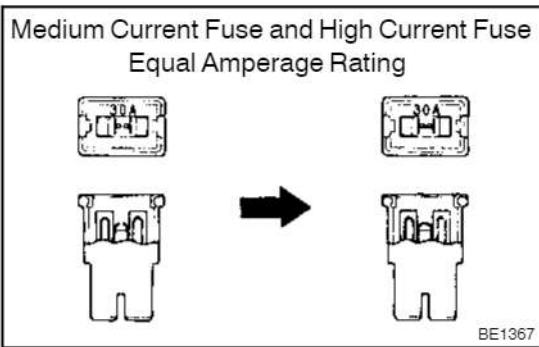

- (j) When replacing fuses, be sure the new fuse has the correct amperage rating. DO NOT exceed the rating or use one with a lower rating.

Illustration	Symbol	Part Name	Abbreviation
<p>BE5594</p>	<p>IN0365</p>	FUSE	FUSE
<p>BE5595</p>	<p>IN0366</p>	MEDIUM CURRENT FUSE	M-FUSE
<p>BE5596</p>	<p>IN0367</p>	HIGH CURRENT FUSE	H-FUSE
<p>BE5597</p>	<p>IN0367</p>	FUSIBLE LINK	FL
<p>BE5598</p>	<p>IN0368</p>	CIRCUIT BREAKER	CB

- (k) Care must be taken when jacking up and supporting the vehicle. Be sure to lift and support the vehicle at the proper locations (See page IN-8).
- Cancel the parking brake on the level place and shift the transmission in Neutral (or N range).
 - When jacking up the front wheels of the vehicle, at first place stoppers behind the rear wheels.
 - When jacking up the rear wheels of the vehicle, at first place stoppers before the front wheels.
 - When either the front or rear wheels only should be jacked up, set rigid racks and place stoppers in front and behind the other wheels on the ground.
 - After the vehicle is jacked up, be sure to support it on rigid racks. It is extremely dangerous to do any work on a vehicle raised on a jack alone, even for a small job that can be finished quickly.
- (l) Observe the following precautions to avoid damage to the following parts:
- (1) Do not open the cover or case of the ECU unless absolutely necessary. (If the IC terminals are touched, the IC may be destroyed by static electricity.)

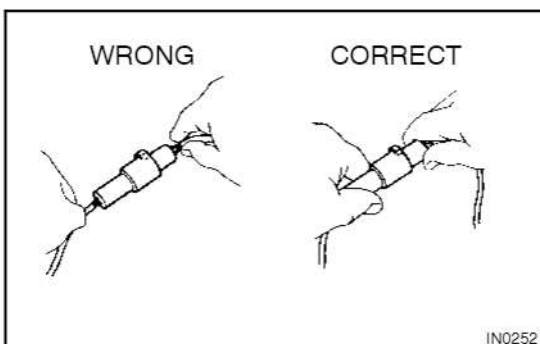
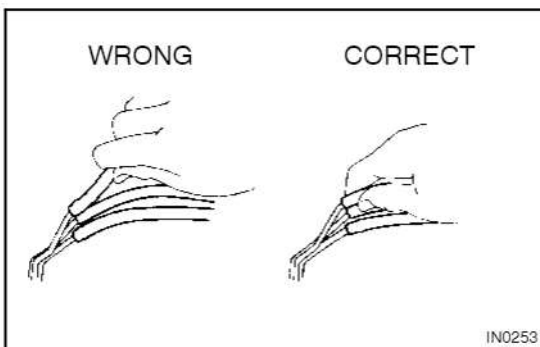

- (2) To disconnect vacuum hoses, pull off the end, not the middle of the hose.
- (3) To pull apart electrical connectors, pull on the connector itself, not the wires.
- (4) Be careful not to drop electrical components, such as sensors or relays. If they are dropped on a hard floor, they should be replaced and not reused.
- (5) When steam cleaning an engine, protect the electronic components, air filter and emission-related components from water.
- (6) Never use an impact wrench to remove or install temperature switches or temperature sensors.
- (7) When checking continuity at the wire connector, insert the tester probe carefully to prevent terminals from bending.
- (8) When using a vacuum gauge, never force the hose onto a connector that is too large. Use a step-down adapter for adjustment. Once the hose has been stretched, it may leak air.

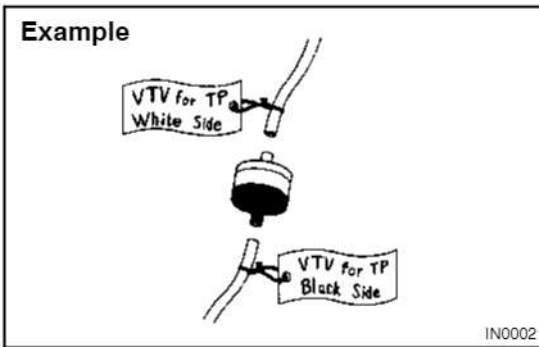

- (m) Installation and removal of vacuum hose:
 - (1) When disconnecting vacuum hoses, use tags to identify how they should be reconnected to.
 - (2) After completing a job, double check that the vacuum hoses are properly connected. A label under the hood shows the proper layout.
- (n) Bleeding of hydraulic brake booster system
When repairing the hydraulic brake booster or ABS, bleeding the air out of the hydraulic brake booster (See Pub No. RM731E, page BR-1.).
- (o) Unless otherwise stated, all resistance is measured at an ambient temperature of 20°C (68°F). Because the resistance may be outside specifications if measured at high temperatures immediately after the vehicle has been running, measurement should be made when the engine has cooled down.

VEHICLE LIFT AND SUPPORT LOCATIONS

RIGID FRONT SUSPENSION (RFS)

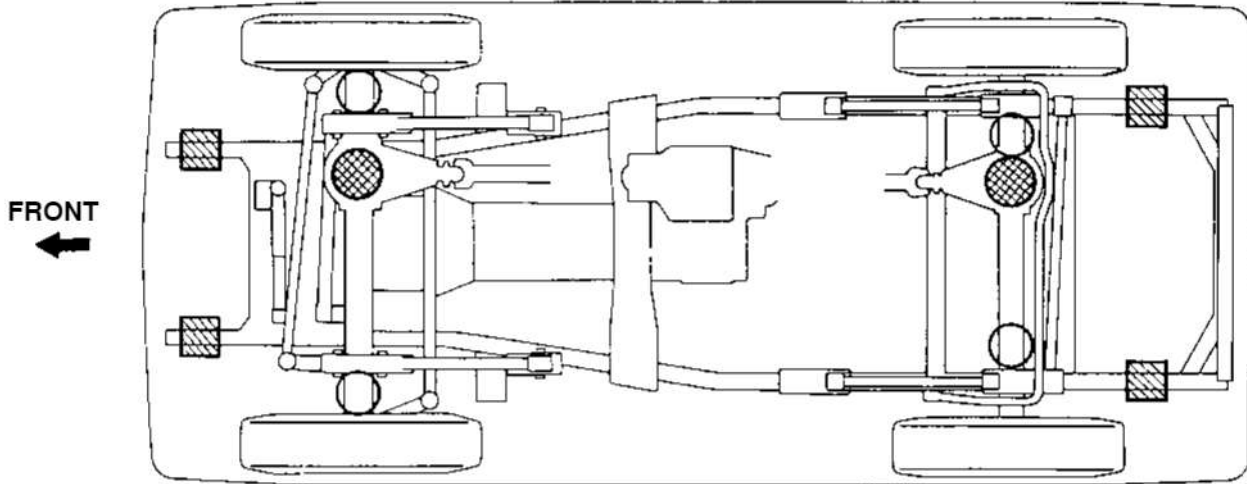

CAUTION : Do not use the swing arm type lift and plate type lift.

JACK POSITION ————— ●

Front Front differential carrier

Rear Rear differential carrier

CAUTION : When jacking-up the front and rear, make sure the car is not carrying any extra weight.

SCREW TYPE JACK POSITION ————— ○

SUPPORT POSITION
Safety stand ▣

INDEPENDENT FRONT SUSPENSION (IFS)

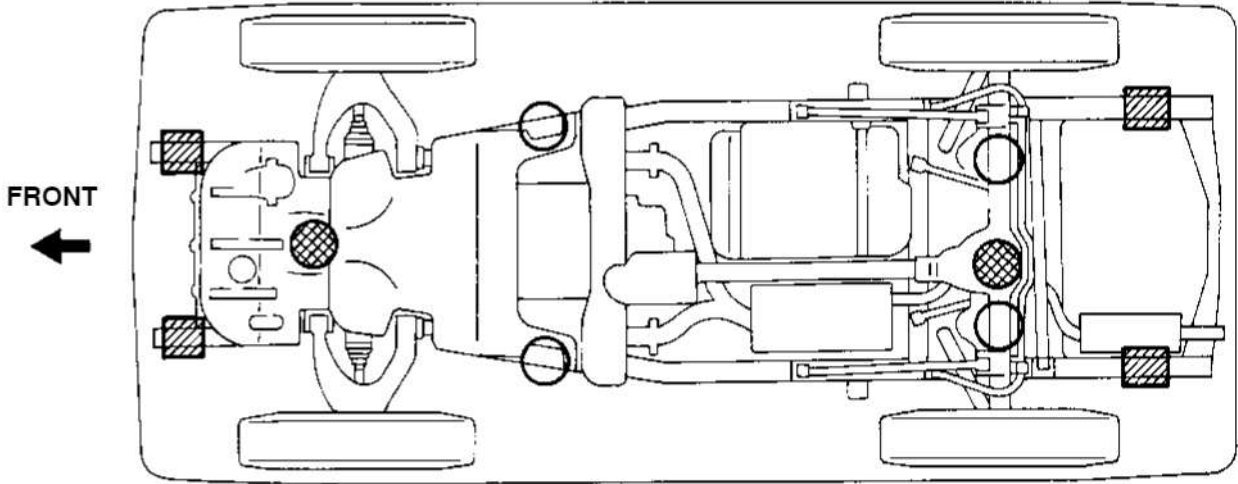

JACK POSITION ————— ●

Front Engine under cover

Rear Rear differential carrier

CAUTION : When jacking-up the front and rear, make sure the car is not carrying any extra weight.

SCREW TYPE JACK POSITION ————— ○

SUPPORT POSITION
Safety stand ▣

NOTICE: (w/ Active Height Control Suspension)
When jacking up the vehicle with the engine running, turn off the active height control suspension with the height control switch pushed.

B04208

cardiagn.com

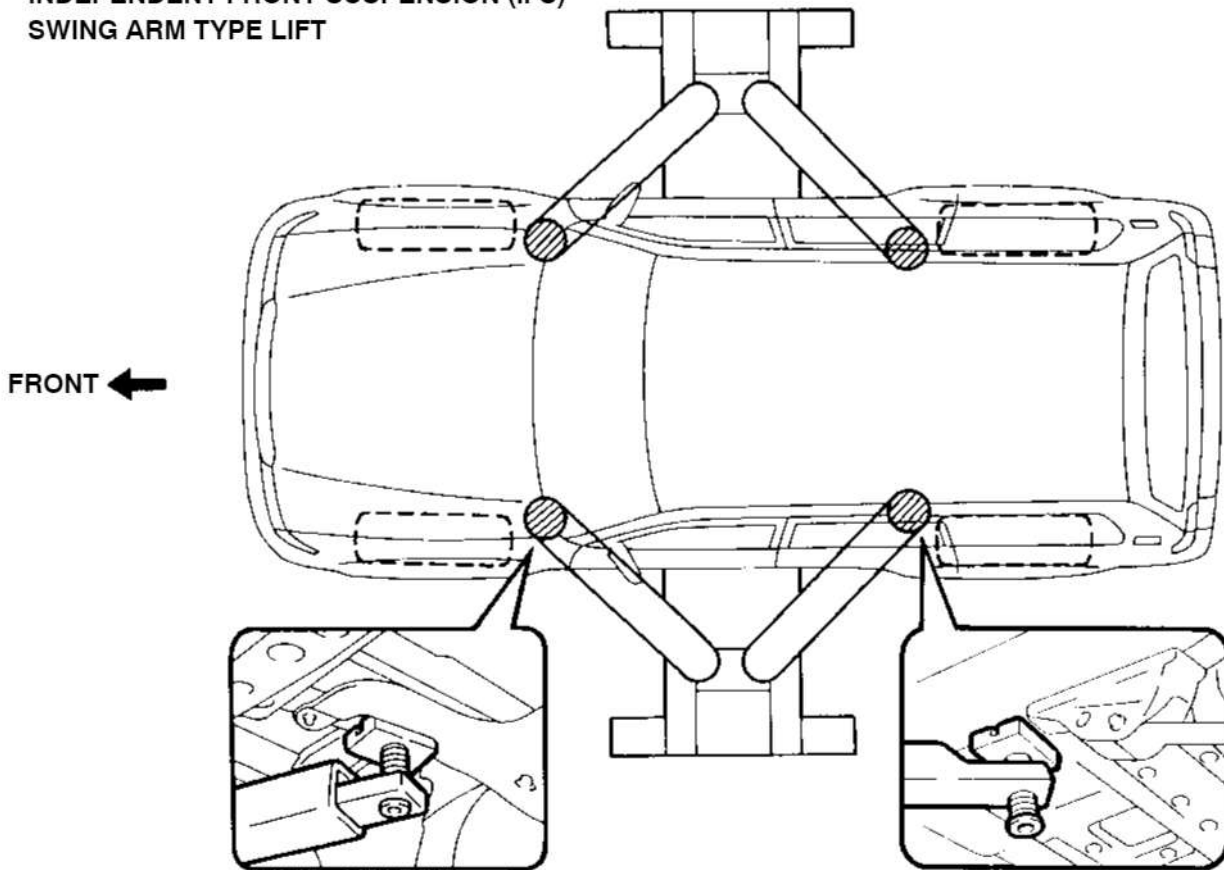
**INDEPENDENT FRONT SUSPENSION (IFS)
SWING ARM TYPE LIFT**

NOTICE: When lifting the vehicle, place the supports correctly at the positions shown above.

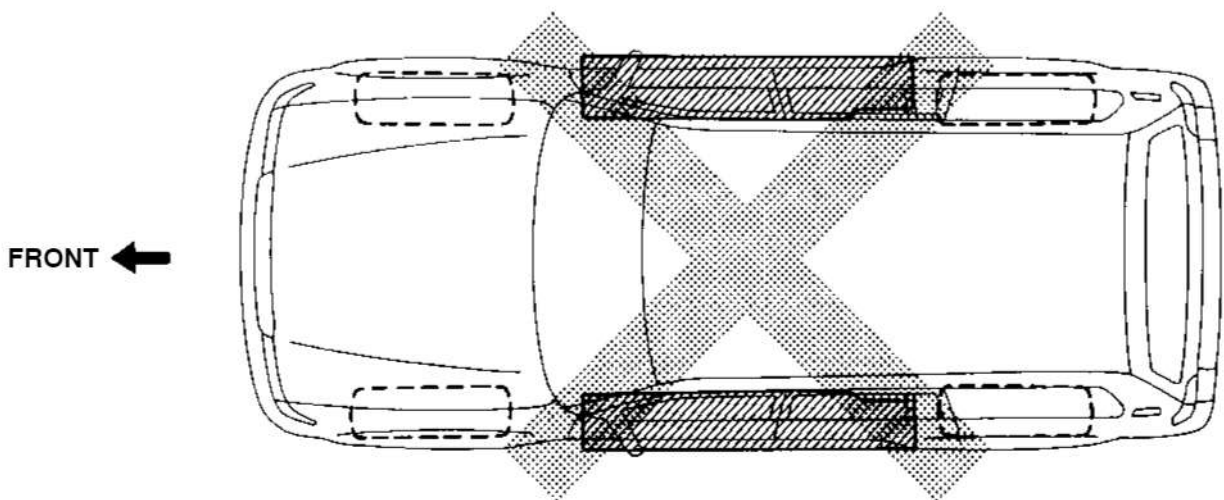
PLATE TYPE LIFT (DO NOT USE.)

NOTICE: Never use the plate type lift—using it to lift up the vehicle will cause the body shape to warp.

B04209

FOR ALL OF VEHICLES PRECAUTION

INQJH-02

1. FOR VEHICLES EQUIPPED WITH SRS AIRBAG AND SEAT BELT PRETENSIONER

- (a) The LAND CRUISER is equipped with an SRS (Supplemental Restraint System), such as the driver airbag, front passenger airbag assembly, side airbag assembly, curtain shield airbag assembly and seat belt pretensioner. Failure to carry out service operations in the correct sequence could cause the supplemental restraint system to unexpectedly deploy during servicing, possibly leading to a serious accident.

Further, if a mistake is made in servicing the supplemental restraint system, it is possible the SRS may fail to operate when required. Before servicing (including removal or installation of parts, inspection or replacement), be sure to read the following items carefully, then follow the correct procedure described in this manual.

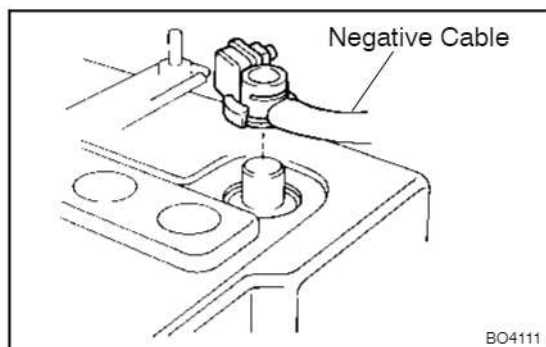

(b) GENERAL NOTICE

- (1) Malfunction symptoms of the supplemental restraint system are difficult to confirm, so the diagnostic trouble codes become the most important source of information when troubleshooting. When troubleshooting the supplemental restraint system, always inspect the diagnostic trouble codes before disconnecting the battery (See Pub. No. RM970E, page DI-421).

- (2) Work must be started after 90 seconds from the time the ignition switch is turned to the "LOCK" position and the negative (-) terminal cable is disconnected from the battery.

(The supplemental restraint system is equipped with a back-up power source so that if work is started within 90 seconds of disconnecting the negative (-) terminal cable from the battery, the SRS may deploy.)

When the negative (-) terminal cable is disconnected from the battery, memory of the clock and audio systems will be cancelled. So before starting work, make a record of the contents memorized by the each memory system. Then when work is finished, reset the clock and audio systems as before. This vehicle has power tilt and power telescopic steering and power seat, which are all equipped with memory function, it is not possible to make a record of the memory contents. So when the work is finished, therefore it will be necessary to explain this fact to the customer, and ask the customer to adjust

the features and reset the memory.

To avoid erasing the memory of each memory system, never use a back-up power supply from another battery.

- (3) Even in cases of a minor collision where the SRS does not deploy, the steering wheel pad, front passenger airbag assembly, side airbag assembly, curtain shield airbag assembly and seat belt pretensioner should be inspected (See Pub. No. RM970E, page RS-18, RS-33, RS-48, RS-63, RS-71 and See Pub. No. RM616E, page BO-213).
- (4) Never use SRS parts from another vehicle. When replacing parts, replace them with new parts.
- (5) Before repairs, remove the airbag sensor if shocks are likely to be applied to the sensor during repairs.
- (6) Never disassemble and repair the airbag sensor assembly, steering wheel pad, front passenger airbag assembly, side airbag assembly, curtain shield airbag assembly or seat belt pretensioner in order to reuse them.
- (7) If the airbag sensor assembly, steering wheel pad, front passenger airbag assembly or seat belt pretensioner have been dropped, or if there are cracks, dents or other defects in the case, bracket or connector, replace them with new ones.
- (8) Do not directly expose the airbag sensor assembly, steering wheel pad, front passenger airbag assembly, side airbag assembly, curtain shield airbag assembly or seat belt pretensioner to hot air or flames.
- (9) Use a volt/ohmmeter with high impedance (10 k Ω /V minimum) for troubleshooting of the electrical circuit.
- (10) Information labels are attached to the periphery of the SRS components. Follow the instructions on the notices.
- (11) After work on the supplemental restraint system is completed, check the SRS warning light (See Pub. No. RM970E, page DI-421).

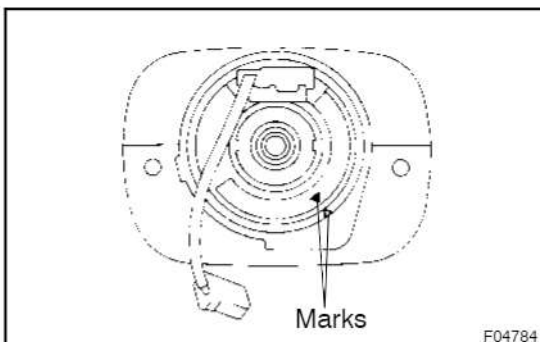

(c) SPIRAL CABLE (in Combination Switch)

The steering wheel must be fitted correctly to the steering column with the spiral cable at the neutral position, otherwise cable disconnection and other troubles may result. Refer to [SR-12](#) of this manual concerning correct steering wheel installation.

(d) STEERING WHEEL PAD (with Airbag)

- (1) When removing the steering wheel pad or handling a new steering wheel pad, it should be placed with the pad top surface facing up.
Storing the pad with its metallic surface facing upward may lead to a serious accident if the airbag inflates for some reason. In addition do not store a steering wheel pad on top of another one.
- (2) Never measure the resistance of the airbag squib. (This may cause the airbag to deploy, which is very dangerous.)
- (3) Grease should not be applied to the steering wheel pad and the pad should not be cleaned with detergents of any kind.
- (4) Store the steering wheel pad where the ambient temperature remains below 93°C (200°F), without high humidity and away from electrical noise.
- (5) When using electric welding, first disconnect the airbag connector (yellow color and 2 pins) under the steering column near the combination switch connector before starting work.
- (6) When disposing of a vehicle or the steering wheel pad alone, the airbag should be deployed using an SST before disposal (See Pub. No. RM970E, page RS-20).
Carry out the operation in a safe place away from electrical noise.

Example:

Correct

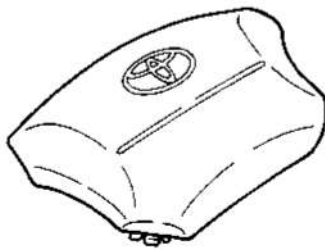

Wrong

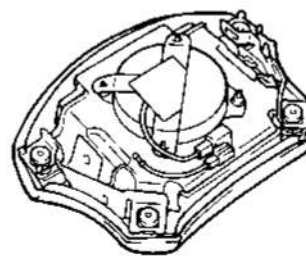

B04199

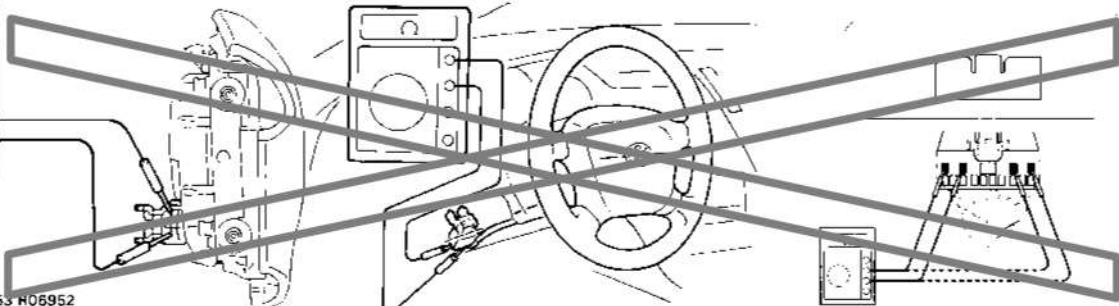
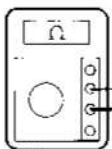
Example:

R05643 R06953 R06952

Z13950

(e) FRONT PASSENGER AIRBAG ASSEMBLY

- (1) Always store a removed or new front passenger airbag assembly with the airbag deployment direction facing up.
Storing the airbag assembly with the airbag deployment direction facing down could cause a serious accident if the airbag inflates.
- (2) Never measure the resistance of the airbag squib. (This may cause the airbag to deploy, which is very dangerous.)
- (3) Grease should not be applied to the front passenger airbag assembly and the airbag door should not be cleaned with detergents of any kind.
- (4) Store the airbag assembly where the ambient temperature remains below 93°C (200°F), without high humidity and away from electrical noise.
- (5) When using electric welding, first disconnect the airbag connector (yellow color and 4 pins) installed on the assembly before starting work.
- (6) When disposing of a vehicle or the airbag assembly alone, the airbag should be deployed using an SST before disposal (See Pub. No. RM970E, page RS-35).
Perform the operation in a safe place away from electrical noise.

Example:

Correct

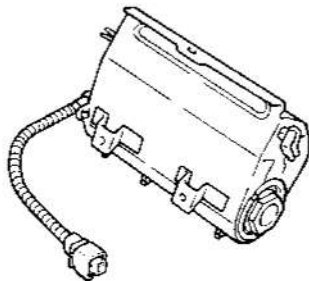

Wrong

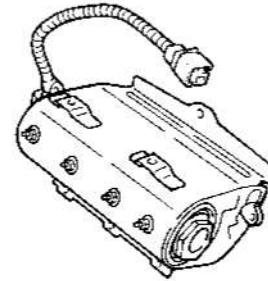

B04717

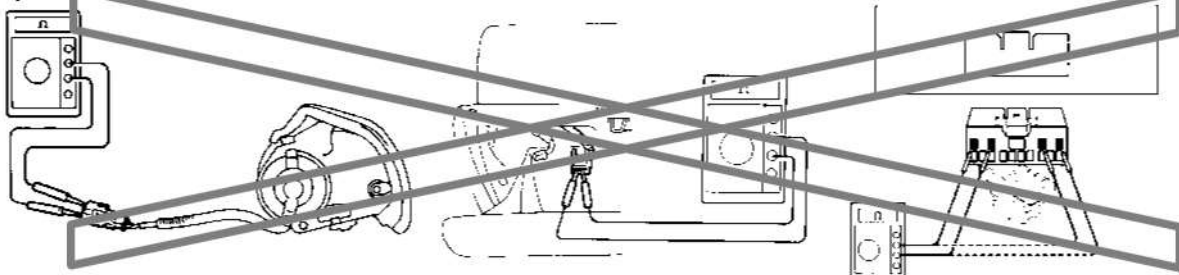
Example:

R05648 R05649 R06952

Z13951

(f) SIDE AIRBAG ASSEMBLY

- (1) Always store a removed or new side airbag assembly with the airbag deployment direction facing up. Storing the airbag assembly with the airbag deployment direction facing downward may lead to a serious accident if the airbag deploys for some.
- (2) Never measure the resistance of the airbag squib reason.
(This may cause the airbag to deploy, which is very dangerous.)
- (3) Grease should not be applied to the side airbag assembly and the surface should not be cleaned with detergents of any kind.
- (4) Store the airbag assembly where the ambient temperature remains below 93°C (200°F), without high humidity and away from electrical noise.
- (5) When using electric welding, first disconnect the air-bag connector (yellow color and 2 pins) under the seat before starting work.
- (6) When disposing of a vehicle or the side airbag assembly alone, the airbag should be deployed using an SST before disposal (See Pub. No. RM970E, page RS-49 or RS-64).
Perform the operation in a safe place away from electrical noise.

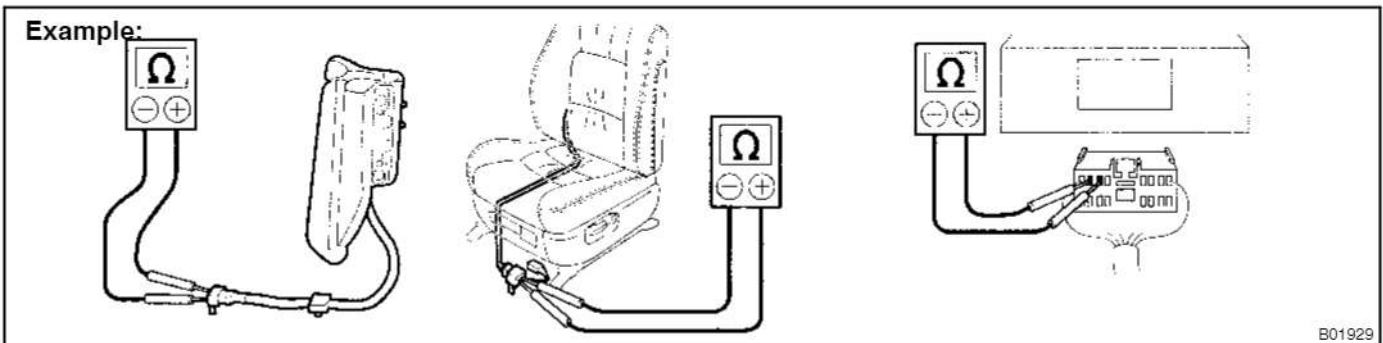
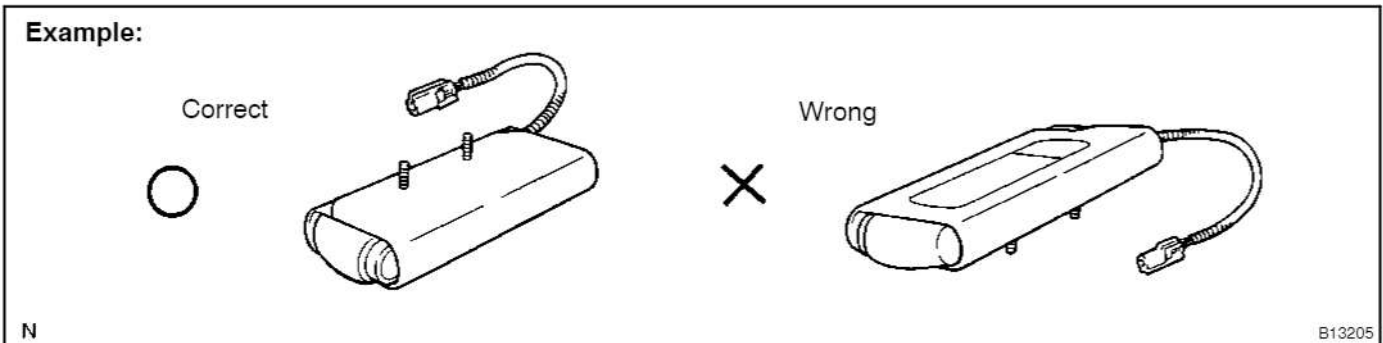

cardiagn.com

(g) CURTAIN SHIELD AIRBAG ASSEMBLY

- (1) Always store a removed or new curtain shield airbag assembly in a clear plastic bag, and keep it in a safe place.

NOTICE:**Protection bag is not reusable.****CAUTION:****Never disassemble the curtain shield airbag assembly.**

- (2) Never measure the resistance of the airbag squib. (This may cause the airbag to deploy, which is very dangerous.)
- (3) Grease should not be attached to the curtain shield airbag assembly and the surface should not be cleaned with detergents of any kind.
- (4) Store the airbag assembly where the ambient temperature remains below 93°C (200°F), without high humidity and away from electrical noise.
- (5) When using electric welding, first disconnect the airbag connector (yellow color and 2 pins) into the instrument panel before starting work.
- (6) When disposing of a vehicle or the curtain shield airbag assembly alone, the airbag should be deployed using an SST before disposal (See Pub. No. RM970E, page RS-72).
Perform the operation in a safe place away from electrical noise.

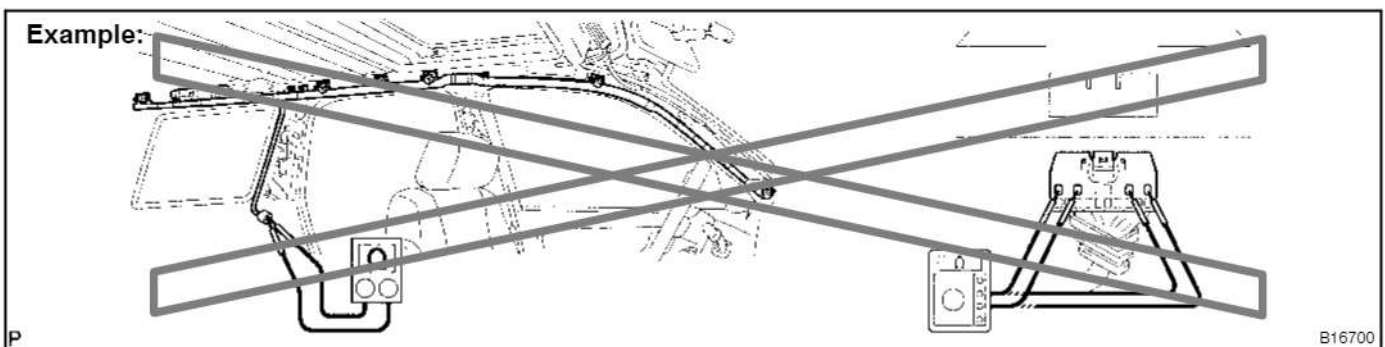
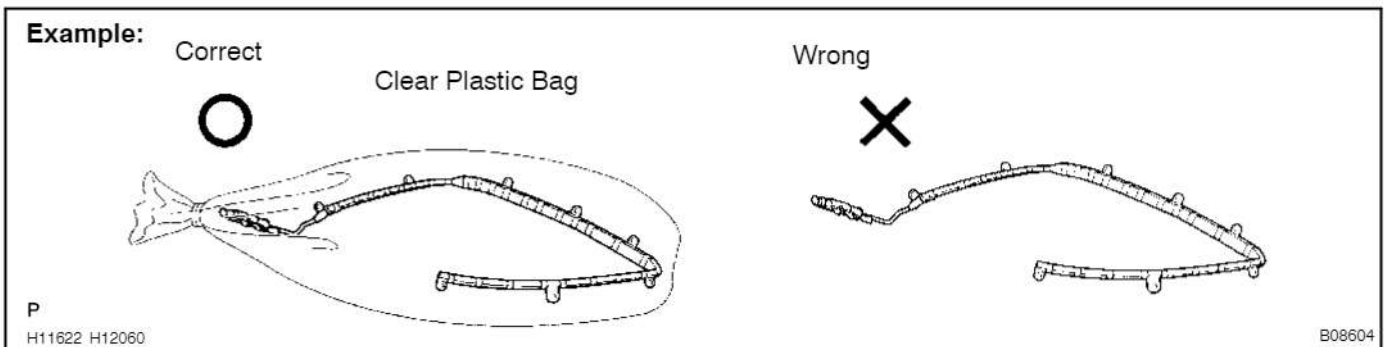

(h) SEAT BELT PRETENSIONER

- (1) Never measure the resistance of the seat belt pretensioner. (This may cause the seat belt pretensioner activation which is very dangerous.)
- (2) Never disassemble the seat belt pretensioner.
- (3) Never install the seat belt pretensioner in another vehicle.
- (4) Store the seat belt pretensioner where the ambient temperature remains below 80°C (176°F) and away from electrical noise without high humidity.
- (5) When using electric welding, first disconnect the connector (yellow color and 2 pins) before starting work.
- (6) When disposing of a vehicle or the seat belt pretensioner alone, the seat belt pretensioner should be activated before disposal (See Pub No. RM616E, page BO-214). Perform the operation in a safe place away from electrical noise.
- (7) The seat belt pretensioner is hot after activation, so let it cool down sufficiently before the disposal. However never apply water to the seat belt pretensioner.

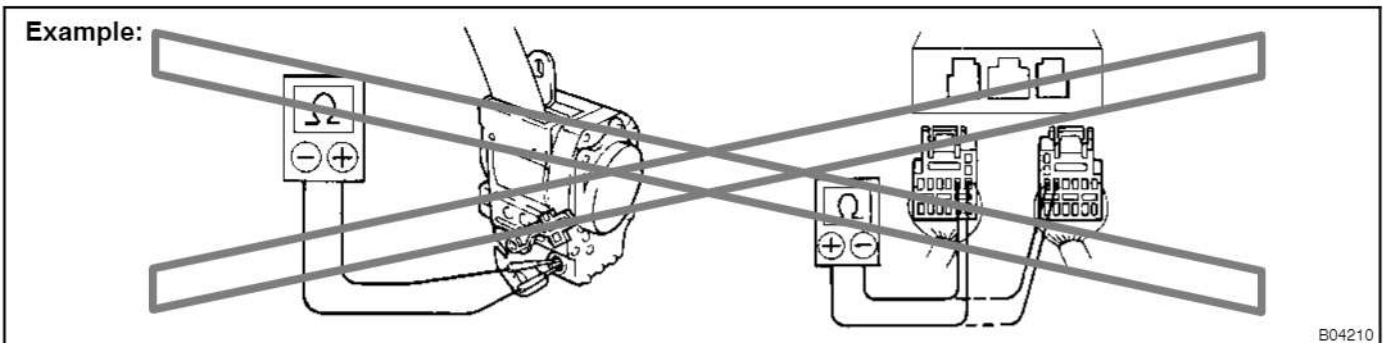

- (i) **AIRBAG SENSOR ASSEMBLY**
 - (1) Never reuse the airbag sensor assembly involved in a collision when the SRS has deployed.
 - (2) The connectors to the airbag sensor assembly should be connected or disconnected with the sensor mounted on the floor. If the connectors are connected or disconnected while the airbag sensor assembly is not mounted to the floor, it could cause undesired ignition of the supplemental restraint system.
 - (3) Work must be started after 90 seconds from the time the ignition switch is turned to the "LOCK" position and the negative (-) terminal cable is disconnected from the battery, even if only loosening the set bolts of the airbag sensor assembly.
- (j) **WIRE HARNESS AND CONNECTOR**

The SRS wire harness is integrated with the instrument panel wire harness assembly. The wires for the SRS wire harness are encased in a yellow corrugated tube and all the connectors in the system are a standard yellow color. If the SRS wire harness becomes disconnected or the connector becomes broken due to an accident, etc., repair or replace it.

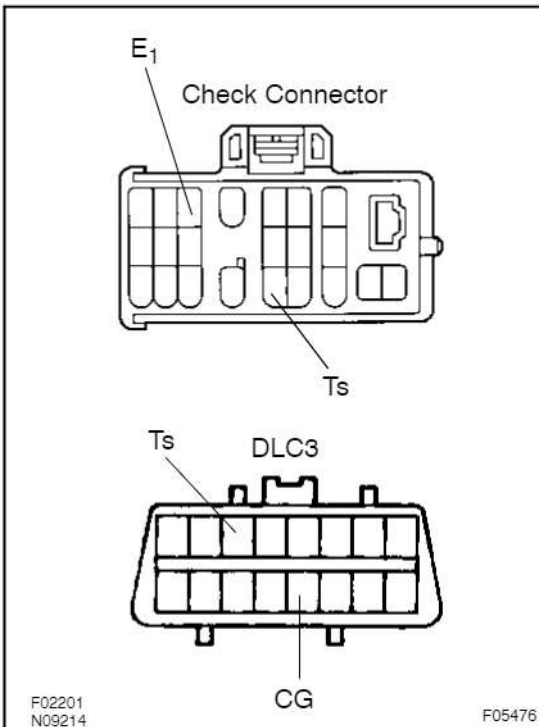

2. FOR VEHICLE EQUIPPED WITH VEHICLE STABILITY CONTROL (VSC) SYSTEM

(a) Precaution when using drum tester:

When using a drum tester, make sure that the ignition switch is OFF, start the engine with the diagnosis connector short-circuited between Ts and E₁ (CG) and take a measurement.

NOTICE:

- Check that VSC warning light is blinking.
- Ensure that the vehicle does not move using wires.
- After the measurement, disconnect the short circuit and check that the VSC warning light is turned off when restarting the engine.

(b) Precaution during VSC operation:

- (1) Since VSC may be affected by the removal/installation of the VSC-related parts, do not remove/install those parts unless absolutely necessary.
- (2) When operating on VSC, follow the instructions in BR section in this manual to surely make preparations or check after operations.

3. WHEN SERVICING FULL-TIME 4WD VEHICLES

The Full-time 4WD LAND CRUISER is equipped with the mechanical lock type center differential system.

During tests using a brake tester or chassis dynamometer, such as braking force tests or speedometer tests, if only the front or rear wheels are to be rotated, it is necessary to set the position of the center differential to FREE or LOCK depending on the type of the test being performed.

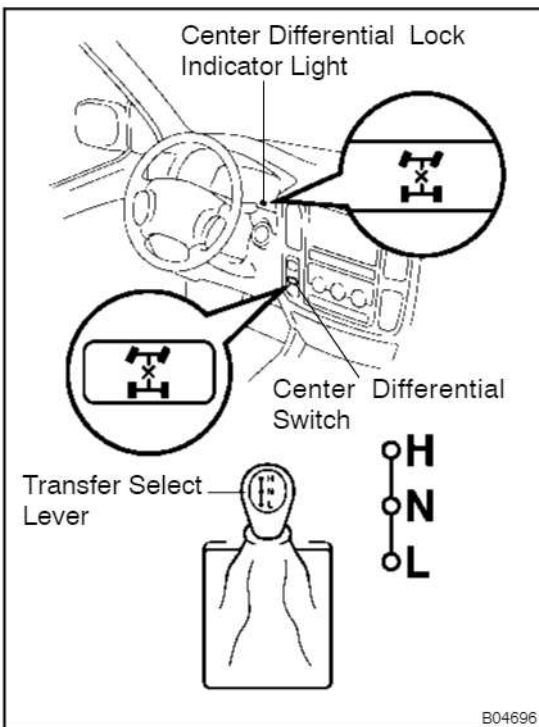

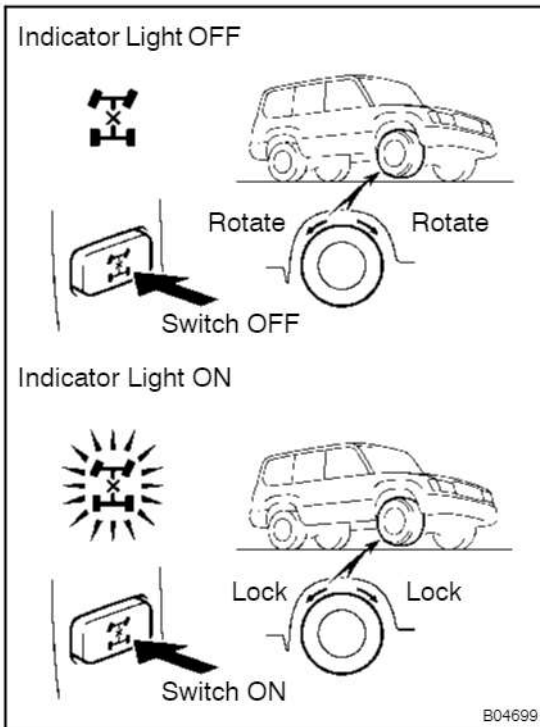

Center differential FREE condition:

	Condition	Wheel
Center differential switch	OFF	A lifted wheel cannot be rotated even if only one wheel is lifted up, as long as transmission is in Neutral (or N range).
Indicator light	OFF	
Transfer select lever (H/L)	w/ VSC: Either will do w/o VSC: H range only	

Center differential LOCK conditions (w/ VSC):

	Condition	Wheel
Center differential switch	ON	A lifted wheel cannot be rotated even if only one wheel is lifted up, as long as transmission is in Neutral (or N range).
Indicator light	ON	
Transfer select lever (H/L)	Either will do	

Center differential LOCK conditions (w/o VSC):

	Condition	Wheel
Center differential switch	ON	A lifted wheel cannot be rotated even if only one wheel is lifted up, as long as transmission is in Neutral (or N range).
Indicator light	ON	
Transfer select lever (H/L)	H position	

	Condition	Wheel
Center differential switch	ON or OFF	A lifted wheel cannot be rotated even if only one wheel is lifted up, as long as transmission is in Neutral (or N range).
Indicator light	ON	
Transfer select lever (H/L)	L position	

HINT:

w/o Vehicle stability control (VSC) system:

When the transfer select lever is put in "L" position, the center differential is put in LOCK condition regardless of the position of the center differential lock switch.

CAUTION:

Center differential "LOCK" ↔ "FREE" selecting procedure:

- Operate the switch only when all of 4 wheels are stopped or driven in a straight line.
- Never operate the switch when any wheel is slipping.
- Never operate the switch when any wheel is spinning freely.
- Never operate the switch when swerving or cornering.

HINT:

- Center differential "LOCK" ↔ "FREE" selecting procedure:
Move the vehicle forward or backward slightly if the indicator light does not operate correctly when the center differential lock switch is turned ON or OFF.

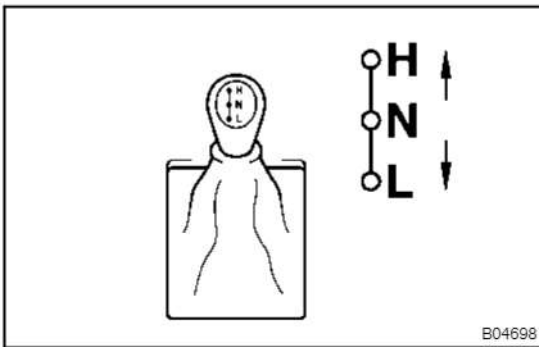

- Transfer gear "H" ↔ "L" gear shifting procedure:
When shifting, always put the shift lever of the transmission in N position. In other positions, the gears of the transfer clash, and switching cannot be performed.

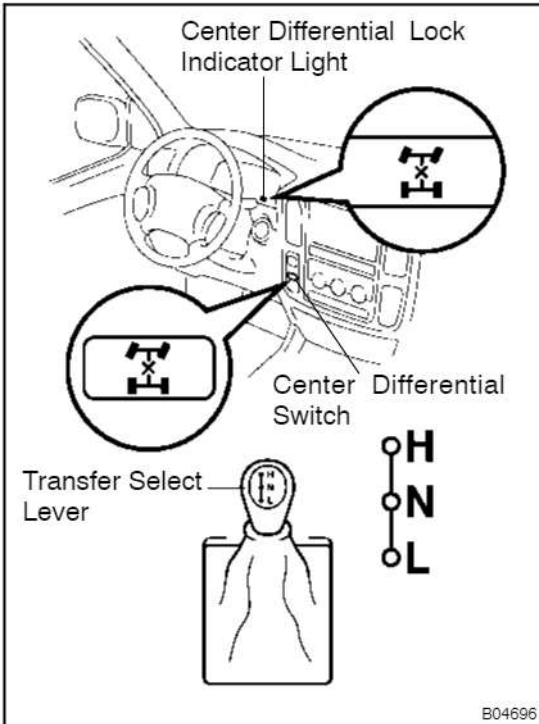

4. WHEN TESTING BRAKES, SPEEDOMETER, ETC.

- (a) When carrying out any kind of servicing or testing on a Full-time 4WD in which the front or rear wheels are to be rotated (braking test, speedometer test), be sure to observe the precautions given below. Incorrect preparations or test procedures may cause danger as well as unsuccessful test results. Before starting any such servicing or test, be sure to check the following items:

- Center differential mode position (FREE or LOCK)

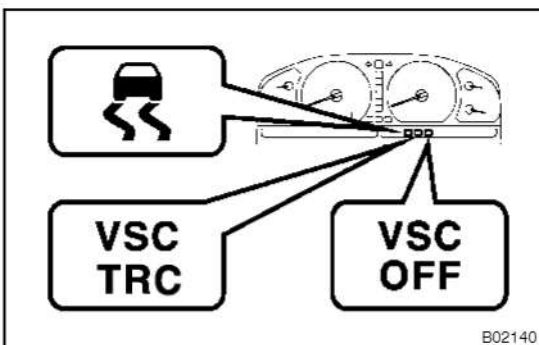

- Vehicle stability control (VSC) system (with or without):
If the vehicle is equipped with the system, the slip indicator light, the VSC/TRC indicator light and the VSC OFF indicator light come on with the ignition key turned to "ON". They will go off after about a few seconds.
- Whether wheels should be touching ground or jacked up
- Transmission gear position (N range)
- Transfer gear position (H or L position)
- Maximum testing vehicle speed
- Maximum testing time

HINT:

w/o Vehicle stability control (VSC) system:

When the transfer select lever is put in "L" position, the center differential is put in LOCK condition regardless of the position of the center differential lock switch.

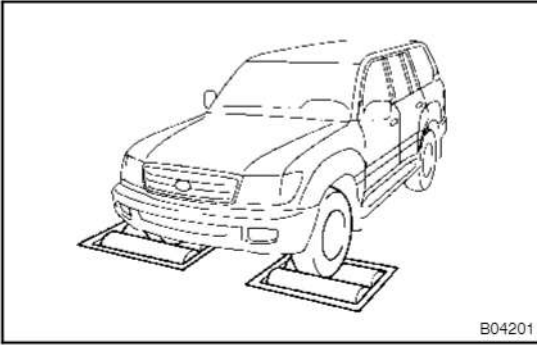

- (b) Using Braking Tester:
 Measure by low-speed type (Vehicle Speed: Below 0.5 km/h or 0.3 mph) brake tester and observe the following instructions before performing the test.
- (1) Position the wheels to be tested (front or rear) on the tester.
 - (2) Put the center differential in FREE position.
 - (3) If the vehicle is equipped with Vehicle Stability Control (VSC) system, prohibit the system from the activation (See step 2.).
 - (4) Shift the transmission shift lever to "N" range.

HINT:

Do not forget to change the Vehicle Stability Control (VSC) & Traction Control (TRC) system to operational condition after the test. Check that the VSC warning indicator light goes off when restarting the engine.

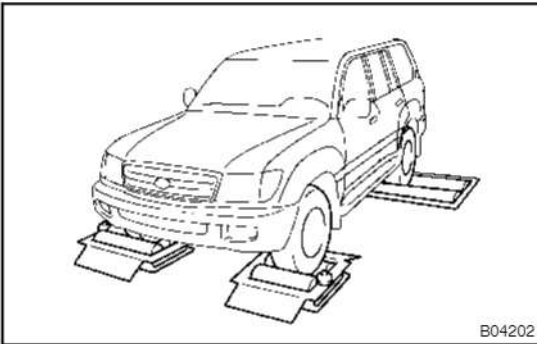

- (c) Using Speedometer Tester:
 Observe the following instructions and then measure with the rear wheels.
- (1) Position the rear wheels on the tester roller.
 - (2) Position the front wheels on the free roller or jack them up.
 - (3) Put the center differential in FREE position.
 - (4) If the vehicle is equipped with Vehicle Stability Control (VSC) & Traction Control (TRC) system, prohibit the system from the activation (See step 2.).
 - (5) Ensure that the vehicle does not move using wires.

CAUTION:

The maximum speed should be less than 60 km/h (37 mph) and maximum driving time should be 1 minute.

HINT:

- Sudden shifting, braking, acceleration or deceleration is not allowed.
- Do not forget to change the Vehicle Stability Control (VSC) & Traction Control (TRC) system to operational condition after the test. Check that the VSC warning indicator light goes off when restarting the engine.

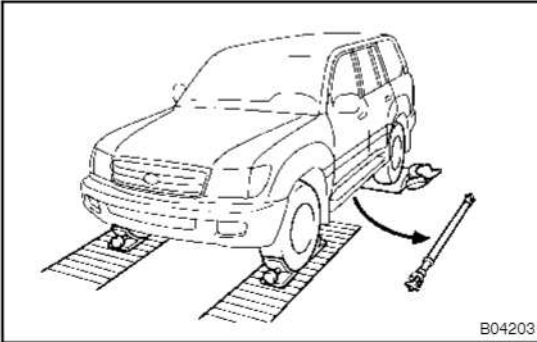

- (d) Using Chassis Dynamometer:
Observe the following instructions and then measure with the rear wheels.
- (1) Remove the front propeller shaft.
 - (2) Put the center differential in LOCK position.
 - (3) If the vehicle is equipped with Vehicle Stability Control (VSC) & Traction Control (TRC) system, prohibit the system from the activation (See step 2.).
 - (4) Ensure that the vehicle is securely fixed.

HINT:

- Sudden shifting, braking, acceleration or deceleration is not allowed.
- Do not forget to change the Vehicle Stability Control (VSC) & Traction Control (TRC) system to operational condition after the test. Check that the VSC warning indicator light goes off when restarting the engine.

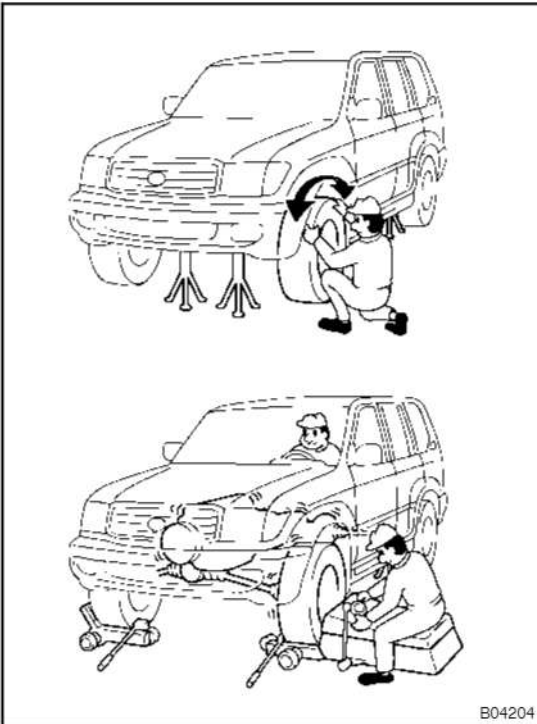

- (e) On-Vehicle Wheel Balancing:
When doing on-vehicle wheel balancing on a full-time 4WD vehicle, to prevent each wheel from being rotated at different speed in different directions (which could damage the center differential), always be sure to observe the following precautions.
- (1) All of 4 wheels should be jacked up, being apart from the ground completely.
 - (2) Put the center differential in LOCK position.
 - (3) If the vehicle is equipped with Vehicle Stability Control (VSC) & Traction Control (TRC) system, prohibit the system from the activation (See step 2.).
 - (4) The parking brake lever should be fully released.
 - (5) None of the brakes should be applied.
 - (6) The wheels should be driven on the wheel balancer with the engine running.
 - (7) Carry out the wheel balancing with the transmission position in D range.

HINT:

- When doing this balancing, pay attention to the other wheels rotating at the same time.
- Sudden acceleration, deceleration or braking is not allowed.
- Do not forget to change the Vehicle Stability Control (VSC) & Traction Control (TRC) system to operational condition after the test. Check that the VSC warning indicator light goes off when restarting the engine.

5. WHEN TOWING FULL-TIME 4WD VEHICLES

- Use one of the methods shown below to tow the vehicle.
- If the vehicle has trouble in the chassis and drive train, use method 1 (flat bed truck).

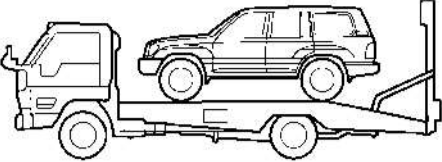
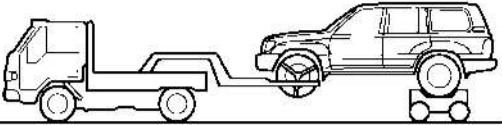
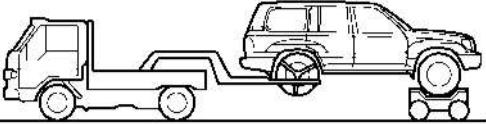
Towing Method	Conditions	Parking Brake	Transmission Shift Lever Position
<p>1. Flat Bed Truck</p> 		Applied	Any Position
<p>2. Wheel Lift Type Truck From Front</p>  <p>From Rear</p> 		Applied	Any Position

B04205

NOTICE:

Do not use any towing method other than those shown above.

- For example, the towing methods shown below are dangerous or damage the vehicle, so do not use them.

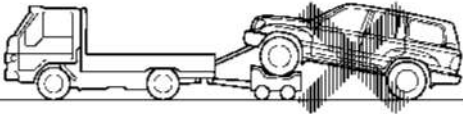
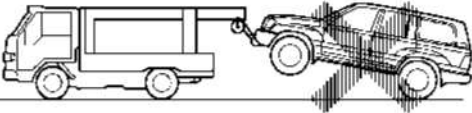
<p style="text-align: center;">NO</p> 	<ul style="list-style-type: none"> • Never tow the vehicle using a method where the lifted-up wheel cannot rotate. • If this towing method is used, either from the front or rear: <ul style="list-style-type: none"> (a) There is a danger of the drive train heating up and causing breakdown, or of the wheels flying off the dolly. (b) In addition, if the vehicle is equipped with the Vehicle Stability Control (VSC) & Traction Control (TRC) system, the system will apply the rotating wheels brake unless the engine isn't shut off.
<p style="text-align: center;">NO</p> 	<p>Do not use the sling type towing method, either from the front or rear, as this method causes damage to the body.</p>

B04206

6. FOR VEHICLES EQUIPPED WITH A CATALYTIC CONVERTER

CAUTION:

If large amount of unburned gasoline flows into the converter, it may overheat and create a fire hazard. To prevent this, observe the following precautions and explain them to your customer.

- (a) Use only unleaded gasoline.
- (b) Avoid prolonged idling.
Avoid running the engine at idle speed for more than 20 minutes.
- (c) Avoid spark jump test.
 - (1) Perform spark jump test only when absolutely necessary. Perform this test as rapidly as possible.
 - (2) While testing, never race the engine.
- (d) Avoid prolonged engine compression measurement.
Engine compression tests must be done as rapidly as possible.
- (e) Do not run engine when fuel tank is nearly empty.
This may cause the engine to misfire and create an extra load on the converter.
- (f) Avoid coasting with ignition turned off and prolonged braking.
- (g) Do not dispose of used catalyst along with parts contaminated with gasoline or oil.

7. IF VEHICLE IS EQUIPPED WITH MOBILE COMMUNICATION SYSTEM

For vehicles with mobile communication systems such as two-way radios and cellular telephones, observe the following precautions.

- (1) Install the antenna as far as possible away from the ECU and sensors of the vehicle's electronic system.
- (2) Install the antenna feeder at least 20 cm (7.87 in.) away from the ECU and sensors of the vehicle's electronic systems. For details about ECU and sensors locations, refer to the section on the applicable component.
- (3) Do not wind the antenna feeder together with the other wiring as much as possible, also avoid running the antenna feeder parallel with other wire harnesses.
- (4) Check that the antenna and feeder are correctly adjusted.
- (5) Do not install powerful mobile communications system.

8. FOR USING HAND-HELD TESTER

CAUTION:

Observe the following items for safety reasons:

- **Before using the hand-held tester, the hand-held tester's operator manual should be read thoroughly.**
- **Be sure to route all cables securely when driving with the hand-held tester connected to the vehicle. (i.e. Keep cables away from feet, pedals, steering wheel and shift lever.)**
- **Two persons are required when test driving with the hand-held tester, one person to drive the vehicle and the other person to operate the hand-held tester.**

HOW TO TROUBLESHOOT ECU CONTROLLED SYSTEMS

IN002-88

GENERAL INFORMATION

A large number of ECU controlled systems are used in the LAND CRUISER (Station Wagon). In general, the ECU controlled system is considered to be a very intricate system requiring a high level of technical knowledge and expert skill to troubleshoot. However, the fact is that if you proceed to inspect the circuits one by one, troubleshooting of these systems is not complex. If you have adequate understanding of the system and a basic knowledge of electricity, accurate diagnosis and necessary repair can be performed to locate and fix the problem. This manual is designed through emphasis of the above standpoint to help service technicians perform accurate and effective troubleshooting, and is compiled for the following major ECU controlled systems:

The troubleshooting procedure and how to make use of it are described on the following pages.

System	Page
1. Automatic Transmission (A750F for 2UZ-FE)	DI-1
2. Automatic Transmission (A750F for 1HD-FTE)	DI-29
3. ABS & Hydraulic Brake Booster Power Supply System	DI-53
4. ABS & Vehicle Stability Control (VSC) & Brake Assist (BA) System	DI-74
5. Variable Gear Ratio Steering	DI-88
6. Navigation System	DI-173
7. Rear View Monitor System	DI-280

FOR USING HAND-HELD TESTER

- Before using the tester, the tester's operator manual should be read thoroughly.
- If the tester cannot communicate with ECU controlled systems when you have connected the cable of the tester to DLC3, turned the ignition switch ON and operated the tester, there is a problem on the vehicle side or tester side.
 - (1) If communication is normal when the tester is connected to another vehicle, inspect the diagnosis data link line (Bus \oplus line) or ECU power circuit of the vehicle.
 - (2) If communication is still not possible when the tester is connected to another vehicle, the problem is probably in the tester itself, so perform the Self Test procedures outline in the Tester Operator's Manual.

HOW TO PROCEED WITH TROUBLESHOOTING

Carry out troubleshooting in accordance with the procedure on the following page. Here, only the basic procedure is shown. Details are provided in Diagnostics section, showing the most effective methods for each circuit. Confirm the troubleshooting procedures first for the relevant circuit before beginning troubleshooting of that circuit.

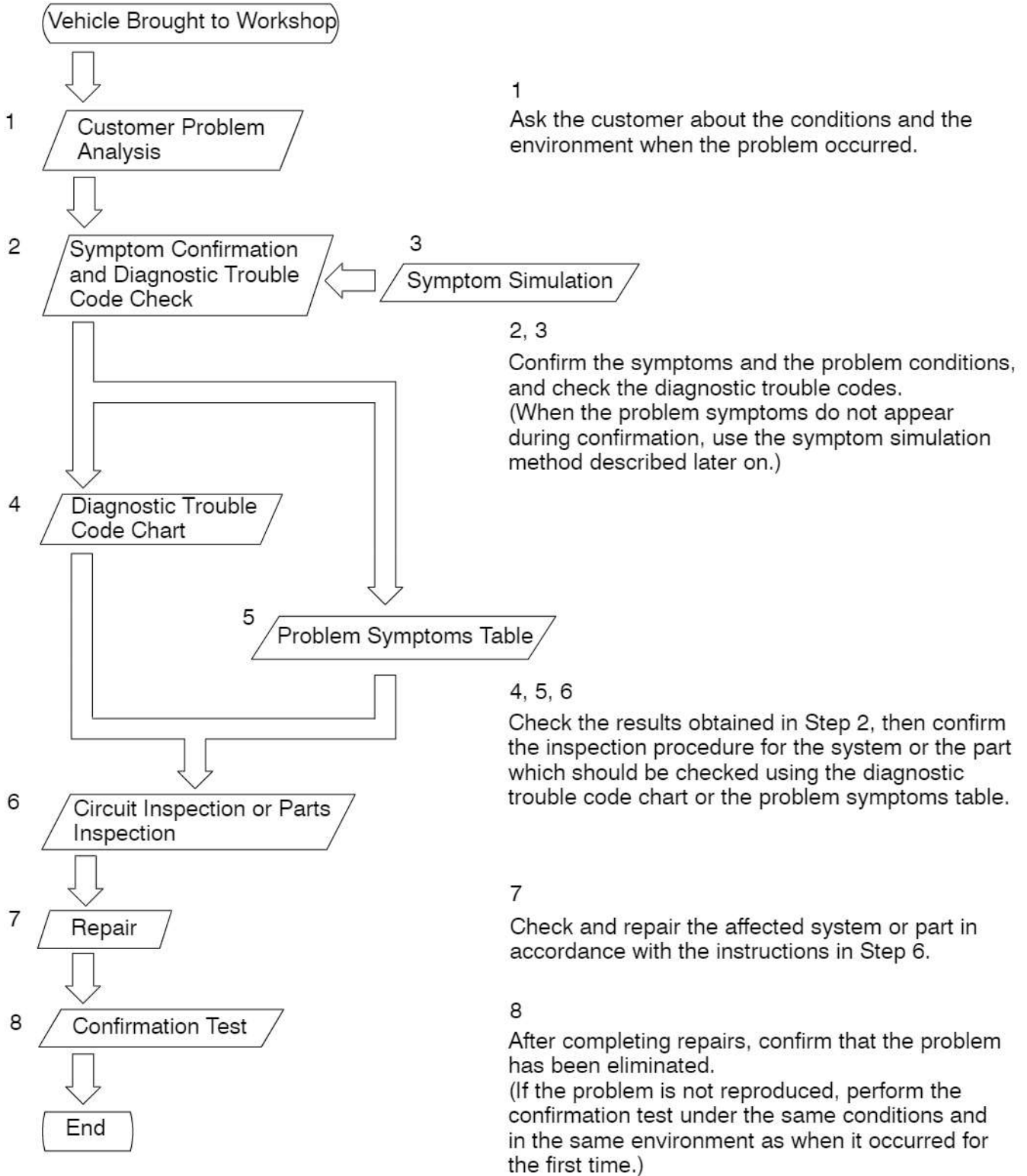

1. CUSTOMER PROBLEM ANALYSIS

In troubleshooting, the problem symptoms must be confirmed accurately and all preconceptions must be cleared away in order to give an accurate judgement. To ascertain just what the problem symptoms are, it is extremely important to ask the customer about the problem and the conditions at the time it occurred.

Important Point in the Problem Analysis:

The following 5 items are important points in the problem analysis. Past problems which are thought to be unrelated and the repair history, etc. may also help in some cases, so as much information as possible should be gathered and its relationship with the problem symptoms should be correctly ascertained for reference in troubleshooting. A customer problem analysis table is provided in Diagnostics section for each system for your use.

Important Points in the Customer Problem Analysis

- What ----- Vehicle model, system name
- When ----- Date, time, occurrence frequency
- Where ----- Road conditions
- Under what conditions? ----- Running conditions, driving conditions, weather conditions
- How did it happen? ----- Problem symptoms

(Sample) Supplemental restraint system check sheet.

CUSTOMER PROBLEM ANALYSIS CHECK			
Supplemental Restraint System Check Sheet		Inspector's Name _____	
Customer's Name		Registration No.	
		Registration Year	/ /
		Frame No.	
Date Vehicle Brought In	/ /	Odometer Reading	km miles
Date Problem First Occurred	/ /		
Weather	<input type="checkbox"/> Fine <input type="checkbox"/> Cloudy <input type="checkbox"/> Rainy <input type="checkbox"/> Snowy <input type="checkbox"/> Other		
Temperature	Approx. _____		
Vehicle Operation	<input type="checkbox"/> Starting <input type="checkbox"/> Idling <input type="checkbox"/> Driving [<input type="checkbox"/> Constant speed <input type="checkbox"/> Acceleration <input type="checkbox"/> Deceleration] <input type="checkbox"/> Other		

2. SYMPTOM CONFIRMATION AND DIAGNOSTIC TROUBLE CODE CHECK

The diagnostic system in the LAND CRUISER Station Wagon fulfills various functions. The first function is the Diagnostic Trouble Code Check in which a malfunction in the signal circuits to the ECU is stored in code in the ECU memory at the time of occurrence, to be output by the technician during troubleshooting. Another function is the Input Signal Check which checks if the signals from various switches are sent to the ECU correctly.

By using these check functions, the problem areas can be narrowed down quickly and troubleshooting can be performed effectively. Diagnostic functions are incorporated in the following systems in the LAND CRUISER Station Wagon.

System	Diagnostic Trouble Code Check	Input Signal Check (Sensor Check)	Diagnosis Test Mode (Active Test)
Automatic Transmission (A750F for 2UZ-FE)	○(with Test Mode)	○	○
Automatic Transmission (A750F for 1HD-FTE)	○(with Test Mode)	○	○
ABS & Hydraulic Brake Booster Power Supply System	○	○	○
ABS & Vehicle Stability Control (VSC) & Brake Assist (BA) System	○	○	○
Variable Gear Ratio Steering	○	○	
Navigation System	○		
Rear View Monitor System	○		

In diagnostic trouble code check, it is very important to determine whether the problem indicated by the diagnostic trouble code is still occurring or occurred in the past but returned to normal at present. In addition, it must be checked in the problem symptom check whether the malfunction indicated by the diagnostic trouble code is directly related to the problem symptom or not. For this reason, the diagnostic trouble codes should be checked before and after the symptom confirmation to determine the current conditions, as shown in the table below. If this is not done, it may, depending on the case, result in unnecessary troubleshooting for normally operating systems, thus making it more difficult to locate the problem, or in repairs not pertinent to the problem. Therefore, always follow the procedure in correct order and perform the diagnostic trouble code check.

DIAGNOSTIC TROUBLE CODE CHECK PROCEDURE

Diagnostic Trouble Code Check (Make a note of and then clear)	Confirmation of Symptoms	Diagnostic Trouble Code Check	Problem Condition
Diagnostic Trouble Code Display	Problem symptoms exist	Same diagnostic trouble code is displayed	Problem is still occurring in the diagnostic circuit
	→	Normal code is displayed	The problem is still occurring in a place other than in the diagnostic circuit (The diagnostic trouble code displayed first is either for a past problem or it is a secondary problem)
	→ No problem symptoms exist		The problem occurred in the diagnostic circuit in the past
Normal Code Display	→ Problem symptoms exist	Normal code is displayed	The problem is still occurring in a place other than in the diagnostic circuit
	→ No problem symptoms exist	Normal code is displayed	The problem occurred in a place other than in the diagnostic circuit in the past

Taking into account the above points, a flow chart showing how to proceed with troubleshooting using the diagnostic trouble code check is shown below. This flow chart shows how to utilize the diagnostic trouble code check effectively, then by carefully checking the results, indicates how to proceed either to diagnostic trouble code troubleshooting or to troubleshooting of problem symptoms table.

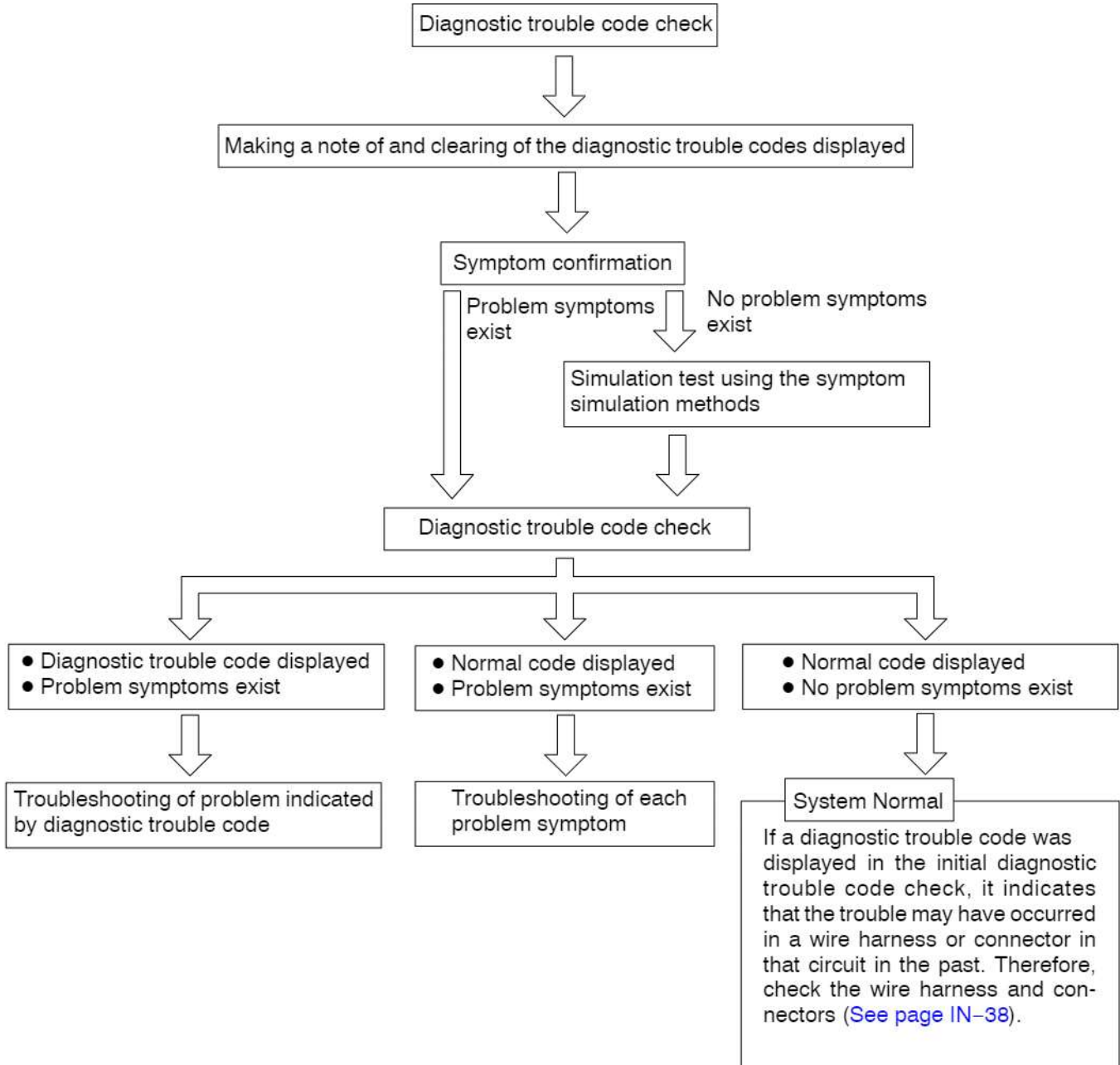

cardiagn.com



3. SYMPTOM SIMULATION

The most difficult case in troubleshooting is when there are no problem symptoms occurring. In such cases, a thorough customer problem analysis must be carried out, then simulate the same or similar conditions and environment in which the problem occurred in the customer's vehicle. No matter how much experience a technician has, or how skilled he or she may be, if he or she proceeds to troubleshoot without confirming the problem symptoms he or she will tend to overlook something important in the repair operation and make a wrong guess somewhere, which will only lead to a standstill. For example, for a problem which only occurs when the engine is cold, or for a problem which occurs due to vibration caused by the road during driving, etc., the problem can never be determined so long as the symptoms are confirmed with the engine hot condition or the vehicle at a standstill. Since vibration, heat or water penetration (moisture) is likely cause for problem which is difficult to reproduce, the symptom simulation tests introduced here are effective measures in that the external causes are applied to the vehicle in a stopped condition.

Important Points in the Symptom Simulation Test:

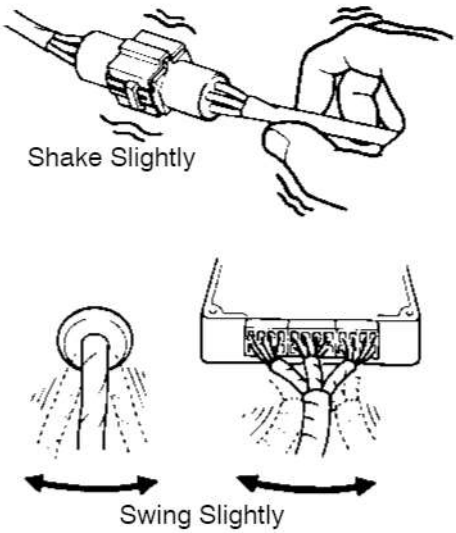
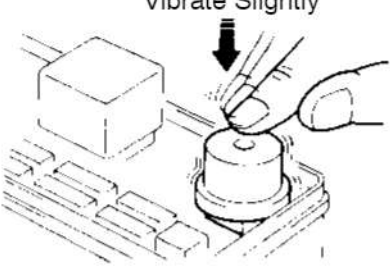
In the symptom simulation test, the problem symptoms should of course be confirmed, but the problem area or parts must also be found out. To do this, narrow down the possible problem circuits according to the symptoms before starting this test and connect a tester beforehand. After that, carry out the symptom simulation test, judging whether the circuit being tested is defective or normal and also confirming the problem symptoms at the same time. Refer to the problem symptoms table for each system to narrow down the possible causes of the symptom.

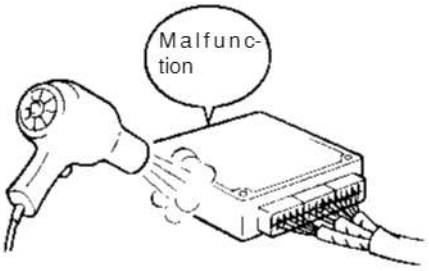
<p>1</p>	<p>VIBRATION METHOD: When vibration seems to be the major cause.</p>
<p>CONNECTORS Slightly shake the connector vertically and horizontally.</p> <p>WIRE HARNESS Slightly shake the wire harness vertically and horizontally. The connector joint, fulcrum of the vibration, and body through portion are the major areas to be checked thoroughly.</p>	 <p>The diagrams illustrate two vibration methods. The top diagram shows a hand holding a connector with the text 'Shake Slightly' and wavy lines indicating movement. The bottom diagram shows a hand holding a wire harness with the text 'Swing Slightly' and arrows indicating swinging motion.</p>
<p>PARTS AND SENSOR Apply slight vibration with a finger to the part of the sensor considered to be the problem cause and check that the malfunction occurs.</p> <p>HINT: Applying strong vibration to relays may result in open relays.</p>	 <p>The diagram shows a hand applying vibration to a sensor component on a circuit board with the text 'Vibrate Slightly' and a downward arrow.</p>

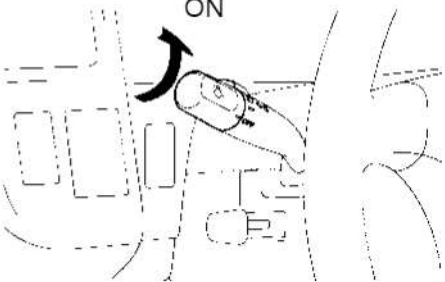
<p>2</p>	<p>HEAT METHOD: When the problem seems to occur when the suspect area is heated.</p>
<p>Heat the component that is the likely cause of the malfunction with a hair dryer or similar object. Check to see if the malfunction occurs.</p> <p>NOTICE:</p> <p>(1) Do not heat to more than 60 °C (140 °F). (Temperature is limited not to damage the components.)</p> <p>(2) Do not apply heat directly to parts in the ECU.</p>	 <p>F12334</p>
<p>3</p>	<p>WATER SPRINKLING METHOD: When the malfunction seems to occur on a rainy day or in a high-humidity condition.</p>
<p>Sprinkle water onto the vehicle and check to see if the malfunction occurs.</p> <p>NOTICE:</p> <p>(1) Never sprinkle water directly into the engine compartment, but indirectly change the temperature and humidity by applying water spray onto the radiator front surface.</p> <p>(2) Never apply water directly onto the electronic components.</p> <p>HINT: If a vehicle is subject to water leakage, the leaked water may contaminate the ECU. When testing a vehicle with a water leakage problem, special caution must be taken.</p>	 <p>F16649</p>
<p>4</p>	<p>OTHER: When a malfunction seems to occur when electrical load is excessive.</p>
<p>Turn on all electrical loads including the heater blower, head lights, rear window defogger, etc. and check to see if the malfunction occurs.</p>	 <p>B02389</p>

cardiagn.com

4. DIAGNOSTIC TROUBLE CODE CHART

The inspection procedure is shown in the table below. This table permits efficient and accurate troubleshooting using the diagnostic trouble codes displayed in the diagnostic trouble code check. Proceed with troubleshooting in accordance with the inspection procedure given in the diagnostic chart corresponding to the diagnostic trouble codes displayed. The Supplemental Restraint System diagnostic trouble code chart is shown below as an example.

● **DTC No.**
Indicates the diagnostic trouble code.

● **Page or Instructions**
Indicates the page where the inspection procedure for each circuit is to be found, or gives instructions for checking and repairs.

● **Trouble Area**
Indicates the suspect area of the problem.

● **Detection Item**
Indicates the system of the problem or contents of the problem.

DIAGNOSTIC TROUBLE CODE CHART
If a malfunction code is displayed during the DTC check, check the circuit for that code listed in the table below. (Proceed to the page given for that circuit).

DTC No. (See page)	Detection Item	Trouble Area	SRS Warming Light
B0100/13 (DI-119)	● Short in D squib circuit	● Steering wheel pad (squib) ● Spiral cable ● Airbag sensor assembly ● Wire harness	ON
B0101/14 (DI-124)	● Open in D squib circuit	● Steering wheel pad (squib) ● Spiral cable ● Airbag sensor assembly ● Wire harness	ON
B0102/11 (DI-128)	● Short in D squib circuit (to ground)	● Steering wheel pad (squib) ● Spiral cable ● Airbag sensor assembly ● Wire harness	ON
B0103/12 (DI-132)	● Short in D squib circuit (to B+)	● Steering wheel pad (squib) ● Spiral cable ● Airbag sensor assembly ● Wire harness	ON
B0105/53 (DI-136)	● Short in P squib circuit	● Front Passenger airbag assembly (squib) ● Airbag sensor assembly ● Wire harness	ON
B0106/54	● Open in P squib circuit	● Front Passenger airbag assembly (squib) ● Airbag sensor assembly ● Wire harness	
	● Short in P squib circuit (to Ground)	● Front Passenger airbag assembly (squib) ● Airbag sensor assembly ● Wire harness	

5. PROBLEM SYMPTOMS TABLE

The suspected circuits or parts for each problem symptom are shown in the table below. Use this table to troubleshoot the problem when a "Normal" code is displayed in the diagnostic trouble code check but the problem is still occurring. Numbers in the table indicate the inspection order in which the circuits or parts should be checked.

HINT:

When the problem is not detected by the diagnostic system even though the problem symptom is present, it is considered that the problem is occurring outside the detection range of the diagnostic system, or that the problem is occurring in a system other than the diagnostic system.

● Page
Indicates the page where the flow chart for each circuit is located.

● Circuit Inspection, Inspection Order
Indicates the circuit which needs to be checked for each problem symptom. Check in the order indicated by the numbers.

● Problem Symptom

● Circuit or Part Name
Indicates the circuit or part which needs to be checked.

PROBLEM SYMPTOMS TABLE
Proceed with troubleshooting of each circuit in the table below.

Symptom	Suspect Area	See page
<ul style="list-style-type: none"> With the ignition switch in the ACC or ON position, the SRS warning light sometimes lights up after approx. 6 seconds have elapsed. SRS warning light is always lit up even when ignition switch is in the LOCK position 	<ul style="list-style-type: none"> SRS warning light circuit (Always lights up when ignition switch is in LOCK position.) 	DI-180
<ul style="list-style-type: none"> With the ignition switch in the ACC or ON position, the SRS warning light does not light up. 	<ul style="list-style-type: none"> SRS warning light circuit (Does not light up when ignition switch is turned to ACC or ON.) 	DI-183
<ul style="list-style-type: none"> DTC is not displayed. SRS warning light is always lit up at the time of DTC check procedure. DTC is displayed without Tc and E1 terminal connection. 	<ul style="list-style-type: none"> Tc terminal circuit 	DI-187

cardiagn.com

6. CIRCUIT INSPECTION

How to read and use each page is shown below.

● Diagnostic Trouble Code No. and Detection Item

● Circuit Description
The major role and operation, etc. of the circuit and its component parts are explained.

DTC	B0100/13	Short in D Squib Circuit
CIRCUIT DESCRIPTION		
The D squib circuit consists of the airbag sensor assembly, spiral cable and steering wheel pad.		
It causes the airbag to deploy when the airbag deployment conditions are satisfied.		
For details of the function of each components, see OPERATION on page RS-2.		
DTC B0100/13 is recorded when a short is detected in the D squib circuit.		
DTC No.	DTC Detecting Condition	Trouble Area
B010013	<ul style="list-style-type: none"> • Short circuit between D+ wire harness and D- wire harness of squib • D squib malfunction • Spiral cable malfunction • Airbag sensor assembly malfunction 	<ul style="list-style-type: none"> • Steering wheel pad (D squib) • Spiral cable • Airbag sensor assembly • Wire harness

● Indicates the diagnostic trouble code, diagnostic trouble code set parameter and suspect area of the problem.

WIRING DIAGRAM

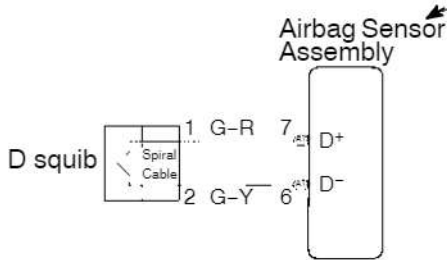

R16015

● Wiring Diagram
This shows a wiring diagram of the circuit. Use this diagram together with ELECTRICAL WIRING DIAGRAM to thoroughly understand the circuit.

Wire colors are indicated by an alphabetical code.
 B = Black, L = Blue, R = Red, BR = Brown,
 LG = Light Green, V = Violet, G = Green,
 O = Orange, W = White, GR = Gray, P = Pink,
 Y = Yellow, SB = Sky Blue

The first letter indicates the basic wire color and the second letter indicates the color of the stripe.

- Indicates the position of the ignition switch during the check.

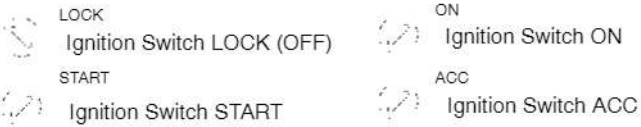

- Inspection Procedure
Use the inspection procedure to determine if the circuit is normal or abnormal, and if it is abnormal, use it to determine whether the problem is located in the sensors, actuators, wire harness or ECU.

INSPECTION PROCEDURE

2 Check voltage at IG2 and ACC of airbag sensor assembly.

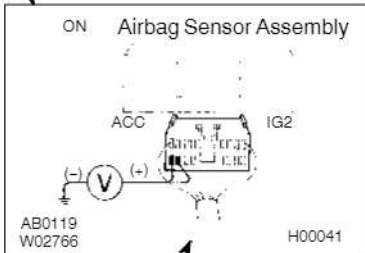

PREPARATION:

Turn ignition switch ON.

CHECK:

Measure voltage between terminals IG2 and ACC of airbag sensor assembly and body ground.

OK:

Voltage: Below 16 V

OK

NG

**Check battery and charging system.
(See charging system section)**

- Indicates the place to check the voltage or resistance.
- Indicates the connector position to be checked, from the front or back side.

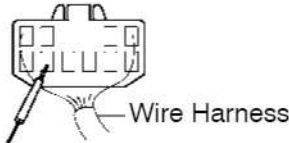

Check from the connector back side.
(with harness)



Check from the connector front side. (without harness)
In this case, care must be taken not to bend the terminals.

- Indicates the condition of the connector of ECU during the check.

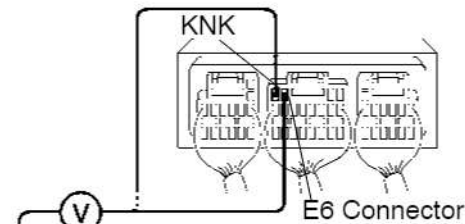

Connector being checked is connected.

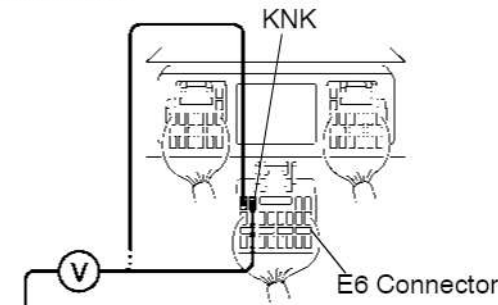

Connector being checked is disconnected.

B00691

B00972

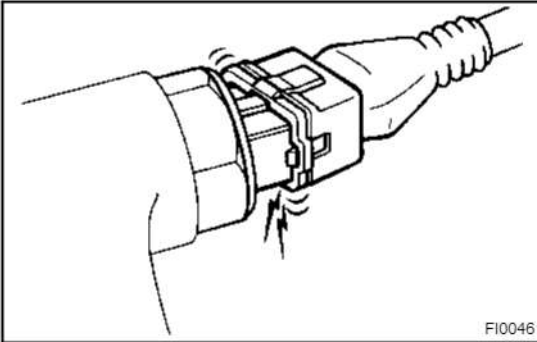

F10046

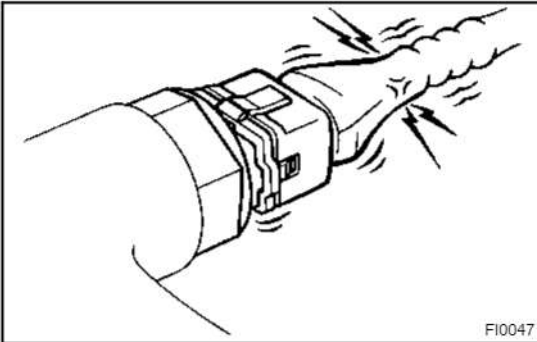

F10047

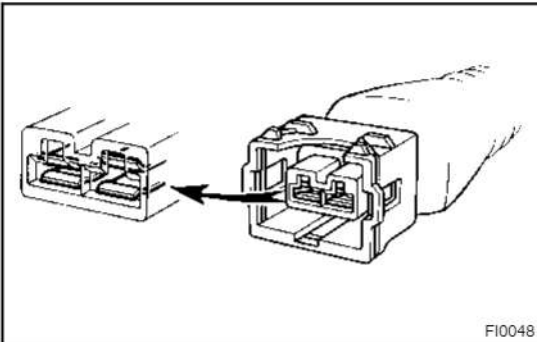

F10048

HOW TO USE THE DIAGNOSTIC CHART AND INSPECTION PROCEDURE

1. CONNECTOR CONNECTION AND TERMINAL INSPECTION

- For troubleshooting, diagnostic trouble code charts or problem symptom table are provided for each circuit with detailed inspection procedures on the following pages.
- When all the component parts, wire harnesses and connectors of each circuit except the ECU are found to be normal in troubleshooting, then it is determined that the problem is in the ECU. Accordingly, if diagnosis is performed without the problem symptoms occurring, refer to Step 8 to replace the ECU. So always confirm that the problem symptoms are occurring, or proceed with inspection while using the symptom simulation method.
- The instructions "Check wire harness and connector" and "Check and replace ECU" which appear in the inspection procedure, are common and applicable to all diagnostic trouble codes. Follow the procedure outlined below whenever these instructions appear.

OPEN CIRCUIT:

This could be due to a disconnected wire harness, faulty contact in the connector, and a connector terminal pulled out, etc.

HINT:

- It is rarely the case that a wire is broken in the middle of it. Most cases occur at the connector. In particular, carefully check the connectors of sensors and actuators
- Faulty contact could be due to rusting of the connector terminals, to foreign materials entering terminals or a deformation of connector terminals. Simply disconnecting and reconnecting the connectors once changes the condition of the connection and may result in a return to normal operation. Therefore, in troubleshooting, if no abnormality is found in the wire harness and connector check, but the problem disappears after the check, then the cause is considered to be in the wire harness or connectors.

SHORT CIRCUIT:

This could be due to a contact between wire harness and the body ground or to a short circuit occurred inside the switch, etc.

HINT:

When there is a short circuit between the wire harness and body ground, check thoroughly whether the wire harness is caught in the body or is clamped properly.

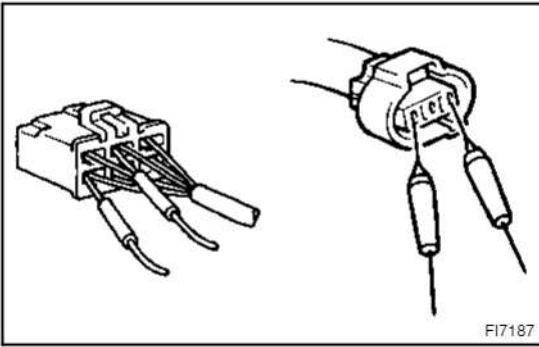

2. CONNECTOR HANDLING

When inserting tester probes into a connector, insert them from the rear of the connector. When necessary, use mini test leads. For water resistant connectors which cannot be accessed from behind, take good care not to deform the connector terminals.

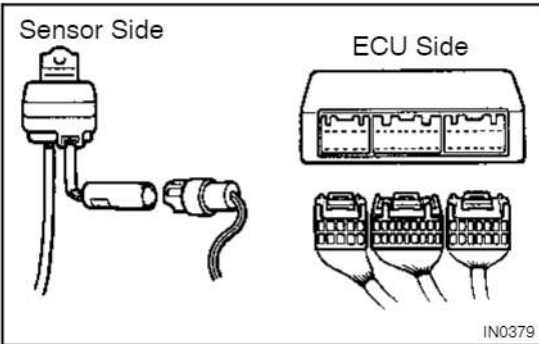

3. CONTINUITY CHECK (OPEN CIRCUIT CHECK)

- (a) Disconnect the connectors at both ECU and sensor sides.
- (b) Measure the resistance between the applicable terminals of the connectors.

Resistance: 1 Ω or less

HINT:

Measure the resistance while lightly shaking the wire harness vertically and horizontally.

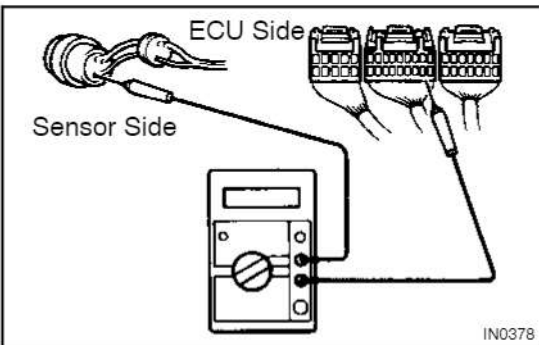

4. RESISTANCE CHECK (SHORT CIRCUIT CHECK)

- (a) Disconnect the connectors on both ends.
- (b) Measure the resistance between the applicable terminals of the connectors and body ground. Be sure to carry out this check on the connectors on both ends.

Resistance: 1 MΩ or higher

HINT:

Measure the resistance while lightly shaking the wire harness vertically and horizontally.

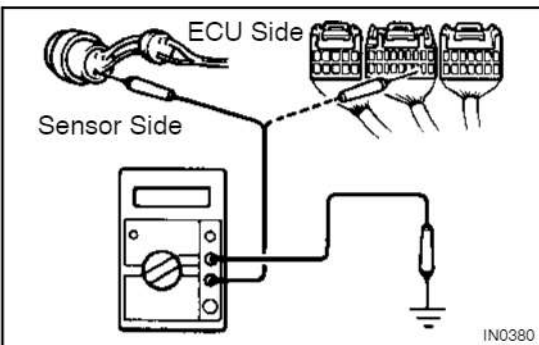

5. VISUAL CHECK AND CONTACT PRESSURE CHECK

- (a) Disconnect the connectors at both ends.
- (b) Check for rust or foreign material, etc. in the terminals of the connectors.
- (c) Check crimped portions for looseness or damage and check that the terminals are secured in lock portion.

HINT:

The terminals should not come out when pulled lightly from the back.

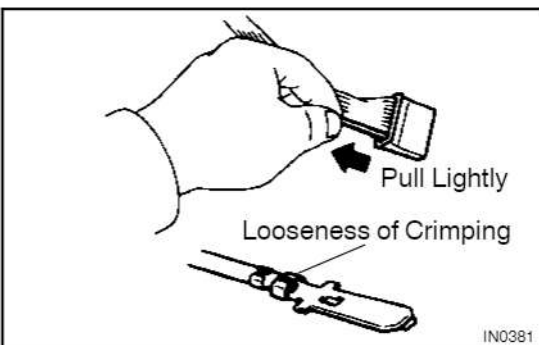

- (d) Prepare a test male terminal and insert it in the female terminal, then pull it out.

NOTICE:

When testing a gold-plated female terminal, always use a gold-plated male terminal.

HINT:

When the test terminal is pulled out more easily than others, there may be poor contact in that section.

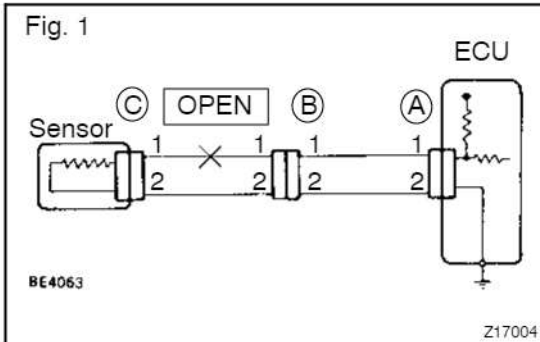
**6. CHECK OPEN CIRCUIT**

For the open circuit in the wire harness in Fig. 1, perform "(a) Continuity Check" or "(b) Voltage Check" to locate the section.

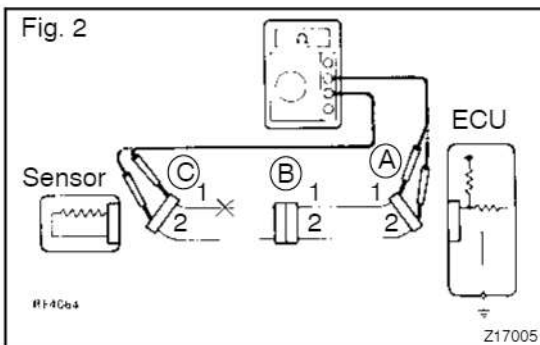

- (a) Check the continuity.

- (1) Disconnect connectors "A" and "C" and measure the resistance between them.

In the case of Fig. 2,

Between terminal 1 of connector "A" and terminal 1 of connector "C" → No continuity (open)

Between terminal 2 of connector "A" and terminal 2 of connector "C" → Continuity

Therefore, it is found out that there is an open circuit between terminal 1 of connector "A" and terminal 1 of connector "C".

- (2) Disconnect connector "B" and measure the resistance between the connectors.

In the case of Fig. 3,

Between terminal 1 of connector "A" and terminal 1 of connector "B1" → Continuity

Between terminal 1 of connector "B2" and terminal 1 of connector "C" → No continuity (open)

Therefore, it is found out that there is an open circuit between terminal 1 of connector "B2" and terminal 1 of connector "C".

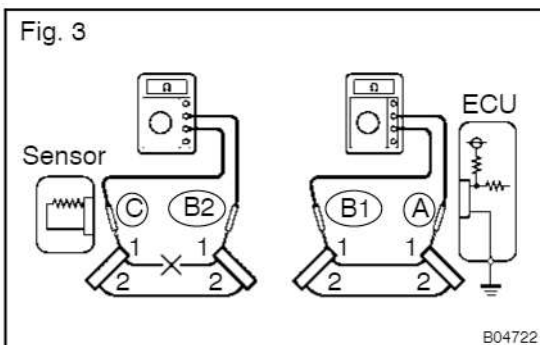

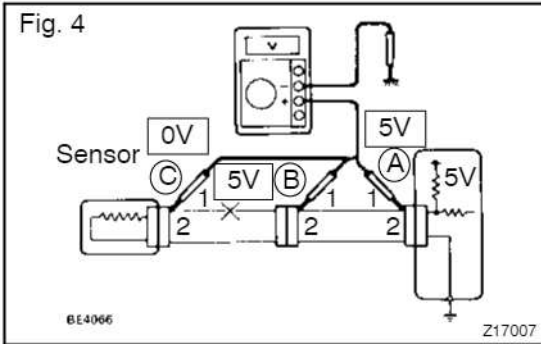

(b) Check the voltage.

In a circuit in which voltage is applied (to the ECU connector terminal), an open circuit can be checked for by conducting a voltage check.

As shown in Fig. 4, with each connector still connected, measure the voltage between body ground and terminal 1 of connector "A" at the ECU 5V output terminal, terminal 1 of connector "B", and terminal 1 of connector "C", in that order.

If the results are:

- 5V: Between Terminal 1 of connector "A" and Body Ground
 - 5V: Between Terminal 1 of connector "B" and Body Ground
 - 0V: Between Terminal 1 of connector "C" and Body Ground
- Then it is found out that there is an open circuit in the wire harness between terminal 1 of "B" and terminal 1 of "C".

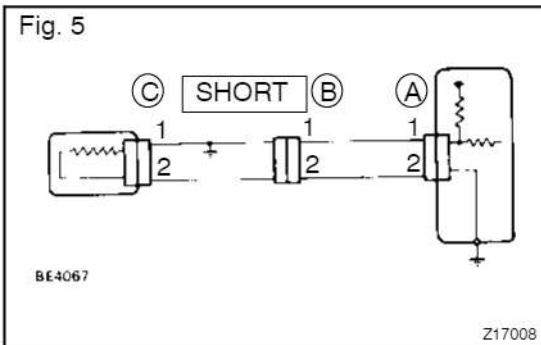

7. CHECK SHORT CIRCUIT

If the wire harness is ground shorted as in Fig. 5, locate the section by conducting a "continuity check with ground".

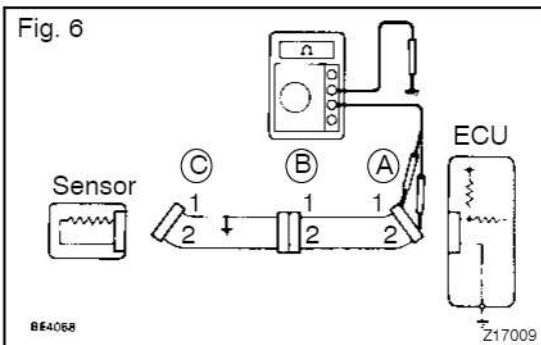

Check the continuity with ground.

- (1) Disconnect connectors "A" and "C" and measure the resistance between terminal 1 and 2 of connector "A" and body ground.

In the case of Fig. 6

Between terminal 1 of connector "A" and body ground → Continuity (short)

Between terminal 2 of connector "A" and body ground → No continuity

Therefore, it is found out that there is a short circuit between terminal 1 of connector "A" and terminal 1 of connector "C".

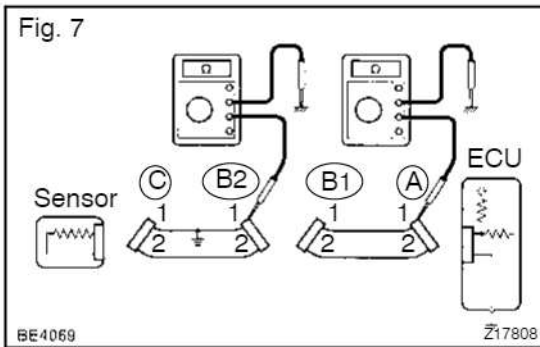

- (2) Disconnect connector "B" and measure the resistance between terminal 1 of connector "A" and body ground, and terminal 1 of connector "B2" and body ground.

Between terminal 1 of connector "A" and body ground → No continuity

Between terminal 1 of connector "B2" and body ground → Continuity (short)

Therefore, it is found out that there is a short circuit between terminal 1 of connector "B2" and terminal 1 of connector "C".

8. CHECK AND REPLACE ECU

First check the ECU ground circuit. If it is faulty, repair it. If it is normal, the ECU could be faulty, so replace the ECU with a normal functioning one and check that the symptoms appear.

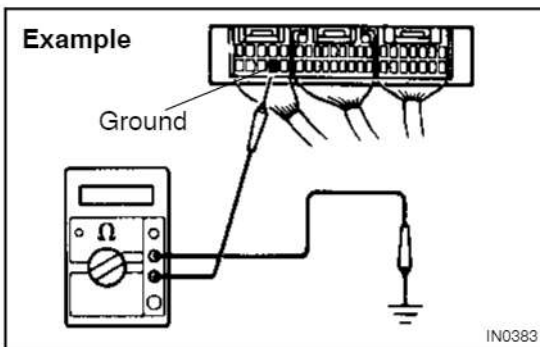

- (1) Measure the resistance between the ECU ground terminal and the body ground.

Resistance: 1 Ω or less

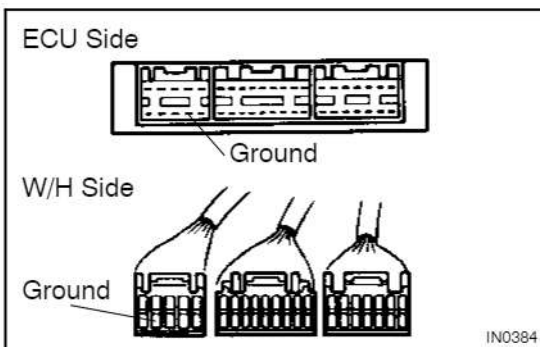

- (2) Disconnect the ECU connector, check the ground terminals on the ECU side and the wire harness side for bend and check the contact pressure.

TERMS**ABBREVIATIONS USED IN THIS MANUAL**

IN08X-02

Abbreviations	Meaning
ABS	Anti-Lock Brake System
A/C	Air Conditioner
AC	Alternating Current
ACC	Accessory
ACIS	Acoustic Control Induction System
ACSD	Automatic Cold Start Device
A.D.D.	Automatic Disconnecting Differential
AHC	Active Height Control Suspension
ALR	Automatic Locking Retractor
ALT	Alternator
AMP	Amplifier
ANT	Antenna
APPROX.	Approximately
A/T	Automatic Transmission (Transaxle)
ATF	Automatic Transmission Fluid
AUTO	Automatic
BA	Brake Assist
BACS	Boost Altitude Compensation System
BAT	Battery
B/L	Bi-Level
BVSV	Bimetallic Vacuum Switching Valve
CB	Circuit Breaker
CD	Compact Disc
CH	Channel
CKD	Complete Knock Down
COMB.	Combination
CPE	Coupe
CRS	Child Restraint System
CTR	Center
DC	Direct Current
DIFF.	Differential
DIFF. LOCK	Differential Lock
DLC	Data Link Connector
DSP	Digital Signal Processor
DTC	Diagnostic Trouble Code
EBD	Electronic Brake Force Distribution
ECT	Electronic Control Transmission
ECU	Electronic Control Unit
EDU	Electronic Driving Unit
EFI	Electronic Fuel Injection
E/G	Engine
ELR	Emergency Locking Retractor

FF	Front-Engine Front-Wheel-Drive
FIPG	Formed In Place Gasket
FL	Fusible Link
Fr	Front
FR	Front-Engine Rear-Wheel-Drive
FWD	Front-Wheel-Drive
GND	Ground
H/B	Hatchback
HI	High
HID	High Intensity Discharge (Head Lamp)
HT	Hard Top
HWS	Heated Windshield System
IAC	Idle Air Control
IFS	Independent Front Suspension
IG	Ignition
INT	Intermittent
I/P	Instrument Panel
IRS	Independent Rear Suspension
J/B	Junction Block
J/C	Junction Connector
LAN	Local Area Network
LB	Liftback
LCD	Liquid Crystal Display
LED	Light Emitting Diode
LH	Left-Hand
LHD	Left-Hand Drive
LO	Low
LSD	Limited Slip Differential
LSP & PV	Load Sensing Proportioning And Bypass Valve
LSPV	Load Sensing Proportioning Valve
MAP	Manifold Absolute Pressure
MAX.	Maximum
MIC	Microphone
MIL	Malfunction Indicator Lamp
MIN.	Minimum
MP	Multipurpose
MPI	Multipoint Electronic Fuel Injection
MPX	Multiplex Communication System
MS	Manual Steering
M/T	Manual Transmission
N	Neutral
No.	Number
O2S	Oxygen Sensor
O/D	Overdrive
OPT	Option
P & BV	Proportioning And Bypass Valve

INTRODUCTION - TERMS

PCS	Power Control System
PKB	Parking Brake
PPS	Progressive Power Steering
PS	Power Steering
PTO	Power Take-Off
RAM	Random Access Memory
R/B	Relay Block
RBS	Recirculating Ball Type Steering
R/F	Reinforcement
RFS	Rigid Front Suspension
RH	Right-Hand
RHD	Right-Hand Drive
RLY	Relay
ROM	Read Only Memory
Rr	Rear
RR	Rear-Engine Rear-Wheel Drive
RRS	Rigid Rear Suspension
RSCA	Rollover Sensing Curtain shield Airbag
RWD	Rear-Wheel Drive
SDN	Sedan
SEN	Sensor
SICS	Starting Injection Control System
SPEC	Specification
SRS	Supplemental Restraint System
SSM	Special Service Materials
SST	Special Service Tools
STD	Standard
SW	Switch
SYS	System
T/A	Transaxle
TACH	Tachometer
TDC	Top Dead Center
TEMP.	Temperature
TEMS	TOYOTA Electronic Modulated Suspension
TFT	Toyota Free-Tronic
T/M	Transmission
TMC	TOYOTA Motor Corporation
TRC	Traction Control System
U/D	Underdrive
VENT	Ventilator
VGRS	Variable Gear Ratio Steering
VIN	Vehicle Identification Number
VSC	Vehicle Stability Control
w/	With
WGN	Wagon
W/H	Wire Harness

w/o	Without
1st	First
2nd	Second
2WD	Two Wheel Drive Vehicle (4x2)
4WD	Four Wheel Drive Vehicle (4x4)

AUTOMATIC TRANSMISSION (A750F)









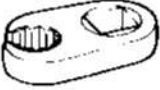

LUBRICANT

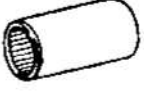
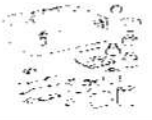
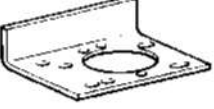
PF1GN-04





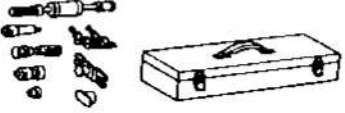

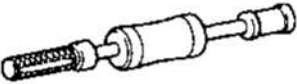
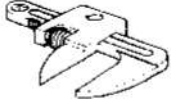

Item	Capacity	Classification
Automatic transmission fluid		
Dry fill	10.6 liters (11.2 US qts, 9.3 Imp qts)	ATF WS
Drain and refill	3.0 liters (3.2 US qts, 2.6 Imp qts)	

STEERING**SST (Special Service Tools)**

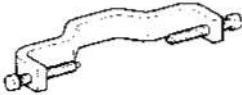
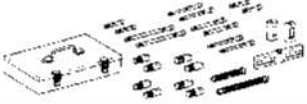
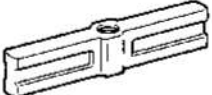
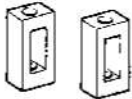





PF41Y-01

	09023-38200	Union Nut Wrench 12mm	POWER STEERING GEAR
	09023-38400	Union Nut Wrench 14mm	POWER STEERING GEAR
	09616-00011	Steering Worm Bearing Adjusting Socket	POWER STEERING GEAR
	09630-00014	Power Steering Gear Housing Overhaul Tool Set	POWER STEERING GEAR
	(09631-00142)	Overhaul Stand	POWER STEERING GEAR
	09631-00230	Rack Seal Guide No.5	POWER STEERING GEAR
	09631-00350	Steering Rack Cover 35	POWER STEERING GEAR
	09631-12071	Steering Rack Oil Seal Test Tool	POWER STEERING GEAR
	09631-20060	Bearing Guide Nut Wrench	POWER STEERING GEAR
	09631-20081	Seal Ring Tool	POWER STEERING GEAR
	09910-00015	Puller Set	POWER TILT AND POWER TELESCOPIC STEERING COLUMN
	(09911-00011)	Puller Clamp	POWER TILT AND POWER TELESCOPIC STEERING COLUMN

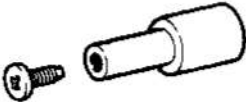
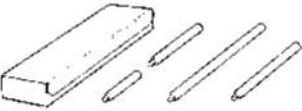

PREPARATION - STEERING

	<p>(09912-00010) Puller Slide Hammer</p>	<p>POWER TILT AND POWER TELESCOPIC STEERING COLUMN</p>
	<p>09922-10010 Variable Open Wrench</p>	<p>POWER STEERING GEAR</p>
	<p>09950-40011 Puller B Set</p>	<p>POWER TILT AND POWER TELESCOPIC STEERING COLUMN</p>
	<p>(09958-04011) Holder</p>	<p>POWER TILT AND POWER TELESCOPIC STEERING COLUMN</p>
	<p>09950-50013 Puller C Set</p>	<p>POWER TILT AND POWER TELESCOPIC STEERING COLUMN</p>
	<p>(09951-05010) Hanger 150</p>	<p>POWER TILT AND POWER TELESCOPIC STEERING COLUMN</p>
	<p>(09952-05010) Slide Arm</p>	<p>POWER TILT AND POWER TELESCOPIC STEERING COLUMN</p>
	<p>(09953-05020) Center Bolt 150</p>	<p>POWER TILT AND POWER TELESCOPIC STEERING COLUMN</p>
	<p>(09954-05021) Claw No.2</p>	<p>POWER TILT AND POWER TELESCOPIC STEERING COLUMN</p>
	<p>09950-60010 Replacer Set</p>	<p>POWER STEERING GEAR</p>
	<p>(09951-00180) Replacer 18</p>	<p>POWER STEERING GEAR</p>
	<p>(09951-00260) Replacer 26</p>	<p>POWER STEERING GEAR</p>
	<p>(09951-00280) Replacer 28</p>	<p>POWER STEERING GEAR</p>

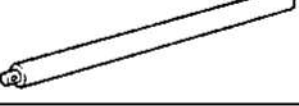
cardiagn.com

	(09951-00320) Replacer 32	POWER STEERING GEAR
	(09951-00330) Replacer 33	POWER STEERING GEAR
	(09951-00360) Replacer 36	POWER STEERING GEAR
	(09952-06010) Adapter	POWER STEERING GEAR
	09950-70010 Handle Set	POWER STEERING GEAR
	(09951-07100) Handle 100	POWER STEERING GEAR
	(09951-07150) Handle 150	POWER STEERING GEAR
	(09951-07200) Handle 200	POWER STEERING GEAR
	(09951-07360) Handle 360	POWER STEERING GEAR

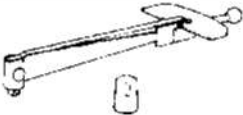
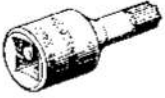
RECOMMENDED TOOLS

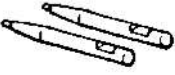
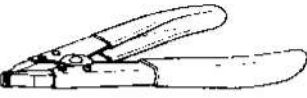
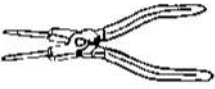
	<p>09025-00010 Small Torque Wrench (30 kgf-cm)</p>	<p>PS gear</p>
	<p>09042-00010 Torx Socket T30 .</p>	<p>Steering column</p>
	<p>09904-00010 Expander Set .</p>	
	<p>(09904-00050) No. 4 Claw</p>	
	<p>09905-00012 Snap Ring No.1 Expander .</p>	
	<p>09905-00013 Snap Ring Pliers .</p>	

cardiagn.com

EQUIPMENT

Dial indicator	PS gear
Torque wrench	

cardiagn.com

SSM (Special Service Materials)

08833-00080 Adhesive 1344 THREE BOND 1344 LOCTITE 242 or equivalent	PS gear (IFS)
--	---------------











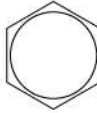

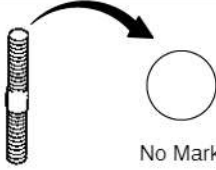
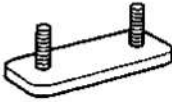















cardiagn.com

STANDARD BOLT

HOW TO DETERMINE BOLT STRENGTH

SS028-01

Bolt Type				Class
Hexagon Head Bolt		Stud Bolt	Weld Bolt	
Normal Recess Bolt	Deep Recess Bolt			
  No Mark	 No Mark	 No Mark		4T
 				5T
  w/ Washer	 w/ Washer			6T
 	 			7T
		 		8T
				9T
	 			10T
	 			11T

cardiagn.com











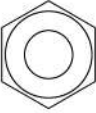
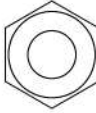
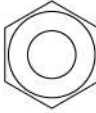



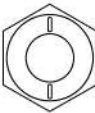

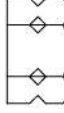
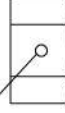
B06431

SPECIFIED TORQUE FOR STANDARD BOLTS

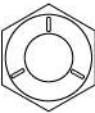
Class	Diameter mm	Pitch mm	Specified torque					
			Hexagon head bolt			Hexagon flange bolt		
			N·m	kgf·cm	ft·lbf	N·m	kgf·cm	ft·lbf
4T	6	1	5	55	48 in.·lbf	6	60	52 in.·lbf
	8	1.25	12.5	130	9	14	145	10
	10	1.25	26	260	19	29	290	21
	12	1.25	47	480	35	53	540	39
	14	1.5	74	760	55	84	850	61
	16	1.5	115	1,150	83	-	-	-
5T	6	1	6.5	65	56 in.·lbf	7.5	75	65 in.·lbf
	8	1.25	15.5	160	12	17.5	175	13
	10	1.25	32	330	24	36	360	26
	12	1.25	59	600	43	65	670	48
	14	1.5	91	930	67	100	1,050	76
	16	1.5	140	1,400	101	-	-	-
6T	6	1	8	80	69 in.·lbf	9	90	78 in.·lbf
	8	1.25	19	195	14	21	210	15
	10	1.25	39	400	29	44	440	32
	12	1.25	71	730	53	80	810	59
	14	1.5	110	1,100	80	125	1,250	90
	16	1.5	170	1,750	127	-	-	-
7T	6	1	10.5	110	8	12	120	9
	8	1.25	25	260	19	28	290	21
	10	1.25	52	530	38	58	590	43
	12	1.25	95	970	70	105	1,050	76
	14	1.5	145	1,500	108	165	1,700	123
	16	1.5	230	2,300	166	-	-	-
8T	8	1.25	29	300	22	33	330	24
	10	1.25	61	620	45	68	690	50
	12	1.25	110	1,100	80	120	1,250	90
9T	8	1.25	34	340	25	37	380	27
	10	1.25	70	710	51	78	790	57
	12	1.25	125	1,300	94	140	1,450	105
10T	8	1.25	38	390	28	42	430	31
	10	1.25	78	800	58	88	890	64
	12	1.25	140	1,450	105	155	1,600	116
11T	8	1.25	42	430	31	47	480	35
	10	1.25	87	890	64	97	990	72
	12	1.25	155	1,600	116	175	1,800	130

cardiagn.com

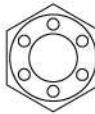
HOW TO DETERMINE NUT STRENGTH

Present Standard Hexagon Nut	Nut Type		Class
	Old Standard Hexagon Nut		
	Cold Forging Nut	Cutting Processed Nut	
 No Mark			4N
 No Mark (w/ Washer)	 No Mark (w/ Washer)	 No Mark	5N (4T)
  			6N
	 	  *	7N (5T)
 			8N
 	 	 No Mark	10N (7T)
 			11N
 			12N

*: Nut with 1 or more marks on one side surface of the nut.

HINT:

Use the nut with the same number of the nut strength classification or the greater than the bolt strength classification number when tightening parts with a bolt and nut.

Example: Bolt = 4T

Nut = 4N or more

LAND CRUISER (W/G) SUP (RM1072E)

AUTOMATIC TRANSMISSION (A750F)

SS028-03

TORQUE SPECIFICATION

Part tightened		N·m	kgf·cm	ft·lbf
No.1 vehicle speed sensor x Transfer case		16	160	12
No.2 vehicle speed sensor x Transmission case	NT	5.4	55	48 in.·lbf
	SP2	5.4	55	48 in.·lbf
ATF temperature sensor (for linear control) x Valve body		11	112	8
ATF temperature sensor (for oil temp warning lamp) x Valve body		10	100	7
ATF temperature sensor x Transmission case		5.4	55	48 in.·lbf
Park/neutral position switch	Bolt	13	130	9
	Nut	3.9	40	35 in.·lbf
Transmission control shaft lever x Transmission control rod		13	130	9
Shift solenoid lock plate x Valve body		6.4	65	57 in.·lbf
Shift solenoid S1 S2 x Valve body		10	102	7
Shift solenoid SR x Valve body		6.4	65	57 in.·lbf
Valve body x Transmission case		11	110	8
Oil stainer x Valve body		10	100	7
Oil pan x Transmission case		4.4	55	39 in.·lbf
Drain plug x Oil pan		20	204	15
Overflow plug x Oil pan		20	204	15
Refill plug x Transmission case		39	400	29
Parking lock pawl bracket x Transmission case		7.4	75	65 in.·lbf
Shift lever assembly x Body		8.3	85	73 in.·lbf
Control lever x Shift lever plate		13	130	9
Transmission control rod x Shift lever assembly		13	130	9
Shift lever guide housing x Shift lever plate		4.9	50	43 in.·lbf
Power steering oil cooler sub-assy x Body		7.5	76	66 in.·lbf
Oil cooler bracket x Body		12	117	8
Oil cooler bracket x Oil cooler		5.0	51	44 in.·lbf
Oil cooler pipe x Body		5.0	51	44 in.·lbf
Engine No. 1 and No. 2 under cover x Body		29	296	21
Transfer shift lever x Transfer shift lever rod assembly		12	122	9
Transfer shift lever boot x Body		5.4	55	48 in.·lbf
Hole plug x Transmission housing		18	185	13
Drive plate x Torque converter clutch		48	490	35
Oil cooler pipe union nut		34	347	25
Crossmember	Bolt	50	510	37
	Nut	74	750	54
Engine mounting insulator rear x Transmission case		59	600	43
Transmission housing x Engine	Bolt A	71	724	52
	Bolt B	37	377	27
Drive plate x Crankshaft	1st	49	500	36
	2nd	Turn 90°	Turn 90°	Turn 90°
Starter x Engine block	(1HD Only)	37	380	27
Front exhaust pipe x Exhaust manifold	(1HD Only)	62	630	46
Front exhaust pipe x Center exhaust pipe	(1HD Only)	40	408	29

SERVICE SPECIFICATIONS - AUTOMATIC TRANSMISSION (A750F)

Stiffener plate x Engine block	(1HD Only)	68	693	50
Oil cooler tube clamp x Clamp	(1HD Only)	12	122	9
LH and RH front exhaust pipe x Exhaust manifold	(2UZ Only)	62	630	46
LH and RH front exhaust pipe x Center exhaust pipe	(2UZ Only)	40	408	29



SUSPENSION AND AXLE

SS00J-19

SERVICE DATA

Front wheel alignment (RFS)	Vehicle height		Clearance*1
	G.C.C.	Front	36.8 mm (1.45 in.)
		Rear	86.7 mm (3.41 in.)
	AUSTRALIA	Front	47.1 mm (1.85 in.)
		Rear	110.0 mm (4.33 in.)
	OTHERS	Front	34.8 mm (1.37 in.)
		Rear	113.0 mm (4.45 in.)
	Camber		$1^{\circ} \pm 45'$ ($1^{\circ} \pm 0.75^{\circ}$)
		Left-right error	45' (0.75°) or less
	Caster (G.C.C.)		$2^{\circ}30' \pm 45'$ ($2.5^{\circ} \pm 0.75^{\circ}$)
		Left-right error	45' (0.75°) or less
Caster (AUSTRALIA)		$1^{\circ}40' \pm 45'$ ($1.67^{\circ} \pm 0.75^{\circ}$)	
	Left-right error	45' (0.75°) or less	
Caster (OTHERS)		$2^{\circ}10' \pm 45'$ ($2.17^{\circ} \pm 0.75^{\circ}$)	
	Left-right error	45' (0.75°) or less	
Steering axis inclination		$13^{\circ} \pm 45'$ ($13^{\circ} \pm 0.75^{\circ}$)	
	Left-right error	45' (0.75°) or less	
Toe-in (total)		$0^{\circ}12' \pm 12'$ ($0.2^{\circ} \pm 0.2^{\circ}$, 2 ± 2 mm, 0.08 ± 0.08 in.)	
Wheel angle	Inside wheel	$32^{\circ} - 35^{\circ}$	
	Outside wheel: Reference	31°	

*Clearance:

Front: Distance from the front axle housing to the following spring

Rear: Distance from the rear axle housing to the bumper stopper

SERVICE SPECIFICATIONS - SUSPENSION AND AXLE

Front wheel alignment (IFS)	Vehicle height (EUROPE)		
	Engine: 2UZ-FE		
	Front	A - B	75.0 mm (2.953 in.)
	Rear	C - D	40.0 mm (1.575 in.)
	Engine: 1HD-FT		
	Front	A - B	76.0 mm (2.992 in.)
	Rear	C - D	41.0 mm (1.614 in.)
	Vehicle height (GENERAL)		
	Engine: 2UZ-FE		
	Front	A - B	76.0 mm (2.992 in.)
	Rear	C - D	31.0 mm (1.220 in.)
	Engine: 1HD-T		
	Front	A - B	76.0 mm (2.992 in.)
	Rear	C - D	34.0 mm (1.339 in.)
Vehicle height (G.C.C.)			
Engine: 2UZ-FE			
Front	A - B	72.0 mm (2.835 in.)	
Rear	C - D	53.0 mm (2.087 in.)	
Engine: 1FZ-FE			
Front	A - B	71.0 mm (2.795 in.)	
Rear	C - D	64.0 mm (2.520 in.)	
Vehicle height (AUSTRALIA)			
Front	A - B	75.0 mm (2.953 in.)	
Rear	C - D	39.0 mm (1.535 in.)	
Vehicle height (w/ AHC System)			
Front	A - B	83.0 mm (3.268 in.)	
Rear	C - D	71.0 mm (2.795 in.)	

- A: Ground clearance of spindle center
- B: Ground clearance of lower suspension arm front bolt center
- C: Ground clearance of rear axle shaft center
- D: Ground clearance of lower control arm front bolt center

EUROPE AND GENERAL (2UZ-FE)		
Camber		0°05' ± 45' (0.08° ± 0.75°)
	Left-right error	30' (0.5°) or less
Caster		2°10' ± 45' (2.17° ± 0.75°)
	Left-right error	30' (0.5°) or less
Steering axis inclination		12°10' ± 45' (12.17° ± 0.75°)
	Left-right error	30' (0.5°) or less
GENERAL (1HD-T)		
Camber		0°05' ± 45' (0.08° ± 0.75°)
	Left-right error	30' (0.5°) or less
Caster		2°25' ± 45' (2.42° ± 0.75°)
	Left-right error	30' (0.5°) or less
Steering axis inclination		12°10' ± 45' (12.17° ± 0.75°)
	Left-right error	30' (0.5°) or less
G.C.C. (2UZ-FE)		
Camber		0°05' ± 45' (0.08° ± 0.75°)
	Left-right error	30' (0.5°) or less
Caster		2°15' ± 45' (2.25° ± 0.75°)
	Left-right error	30' (0.5°) or less

cardiagn.com

Front wheel alignment (IFS)	Steering axis inclination		$12^{\circ}10' \pm 45'$ ($12.17^{\circ} \pm 0.75^{\circ}$)	
		Left-right error	30' (0.5°) or less	
	G.C.C. (1FZ-FE)			
	Camber		$0^{\circ}05' \pm 45'$ ($0.08^{\circ} \pm 0.75^{\circ}$)	
		Left-right error	30' (0.5°) or less	
	Caster		$2^{\circ}50' \pm 45'$ ($2.83^{\circ} \pm 0.75^{\circ}$)	
		Left-right error	30' (0.5°) or less	
	Steering axis inclination		$12^{\circ}10' \pm 45'$ ($12.17^{\circ} \pm 0.75^{\circ}$)	
		Left-right error	30' (0.5°) or less	
	AUSTRALIA			
	Camber		$0^{\circ}05' \pm 45'$ ($0.08^{\circ} \pm 0.75^{\circ}$)	
		Left-right error	30' (0.5°) or less	
	Caster		$2^{\circ}10' \pm 45'$ ($2.17^{\circ} \pm 0.75^{\circ}$)	
		Left-right error	30' (0.5°) or less	
	Steering axis inclination		$12^{\circ}10' \pm 45'$ ($12.17^{\circ} \pm 0.75^{\circ}$)	
	Left-right error	30' (0.5°) or less		
w/ AHC System				
Camber		$0^{\circ}00' \pm 45'$ ($0^{\circ} \pm 0.75^{\circ}$)		
	Left-right error	30' (0.5°) or less		
Caster		$3^{\circ}05' \pm 45'$ ($3.08^{\circ} \pm 0.75^{\circ}$)		
	Left-right error	30' (0.5°) or less		
Steering axis inclination		$12^{\circ}15' \pm 45'$ ($12.25^{\circ} \pm 0.75^{\circ}$)		
	Left-right error	30' (0.5°) or less		
w/ AHC System				
Toe-in (total)		$0^{\circ}00' \pm 12'$ ($0^{\circ} \pm 0.2^{\circ}$, 0 ± 2 mm, 0 ± 0.08 in.)		
	Rack end length difference	3.0 mm (0.118 in.) or less		
OTHERS				
Toe-in (total)		$0^{\circ}06' \pm 12'$ ($0.1^{\circ} \pm 0.2^{\circ}$, 1 ± 2 mm, 0.04 ± 0.08 in.)		
	Rack end length difference	3.0 mm (0.118 in.) or less		
Front wheel alignment (IFS)	Wheel angle	Inside wheel	$36^{\circ}42'$ ($33^{\circ}42' - 36^{\circ}42'$) 36.7° ($33.7^{\circ} - 36.7^{\circ}$)	
		Outside wheel: Reference	$32^{\circ}36'$ 32.6°	

STEERING

SERVICE DATA

SS020-03

POWER STEERING GEAR (IFS)		
Steering rack runout	Maximum	0.30 mm (0.0118 in.)
Total preload	Center area	1.8 – 2.2 N·m (18.4 – 22.4 kgf·cm, 16.0 – 19.5 in.·lbf)
	End area	1.3 – 1.7 N·m (13.3 – 17.3 kgf·cm, 11.5 – 15.0 in.·lbf)



TORQUE SPECIFICATION

Part tightened	N·m	kgf·cm	ft·lbf
POWER TILT AND POWER TELESCOPIC STEERING COLUMN			
Steering column protector No. 1 set bolt	15	150	11
Power tilt motor set bolt	20	210	15
Power telescopic motor set bolt	8.8	90	78 in.·lbf
Column tube stopper	19	190	14
Tube attachment x Column tube	15	150	11
Telescopic steering slider support set bolt	11	110	8
Telescopic steering screw set nut	2.0	20	17 in.·lbf
No. 2 lower cover set nut	25	260	19
Column upper tube sub-assembly x Column upper tube assembly	20	210	15
Telesco lever lock bolt	10	100	7
POWER STEERING GEAR (IFS)			
Cylinder end stopper	110 (145)	1,122 (1,480)	81 (107)
Bearing guide nut	24.5	250	19
Control valve housing set bolt	18	180	13
Rack guide spring cap	25	250	18
Rack guide spring cap lock nut	51 (70)	520 (700)	38 (51)
Rack x Rack end	99 (132)	1,014 (1,350)	74 (98)
Tie rod end lock nut	55	560	41
Turn pressure tube union nut	23 (24.5)	230 (250)	17 (18)
PS gear assembly set bolt and nut	120	1,250	89
Return tube x Control valve housing	40 (44)	409 (450)	29 (29)
Pressure feed tube x Control valve housing	42	430	31
Tube clamp set bolt	18	180	13

(): For use without SST

AUTOMATIC TRANSMISSION (A750F for 2UZ-FE)

DIAUB-02

HOW TO PROCEED WITH TROUBLESHOOTING

When using hand-held tester, troubleshoot in accordance with the procedure on the following pages.

Vehicle Brought to Workshop

Items inside  are titles of pages in this manual, with the page number indicated in the bottom portion. See the indicated pages for detailed explanations.

1 Customer Problem Analysis
P. DI-4

2 Connect the hand-held tester to DLC3.
If the display shows "UNABLE TO CONNECT TO VEHICLE" when you have connected the hand-held tester, inspect DLC3 P. DI-5

3 Check DTC and Freeze Frame Data (Precheck)
Record or Print DTC and Freeze Frame Data P. DI-5

4 Clear DTC and Freeze Frame Data P. DI-5

5 Visual Inspection

★: Refer LAND CRUISER Chassis and Body Repair Manual Supplement (Pub. No. RM970E).

6 Setting the Check Mode Diagnosis P. DI-5

7 Problem Symptom Confirmation
Symptom does not occur → 8 Symptom Simulation P. IN-27
Symptom occur → 9

9 DTC Check P. DI-5
OK Code → 11 Basic Inspection P. DI-5
NG → 10

10 DTC Chart ★

11 Basic Inspection P. DI-5
OK → 12 Mechanical System Test P. DI-5
NG → 10

12 Mechanical System Test P. DI-5
OK → 13 Manual Shifting Test P. DI-5
NG → 10

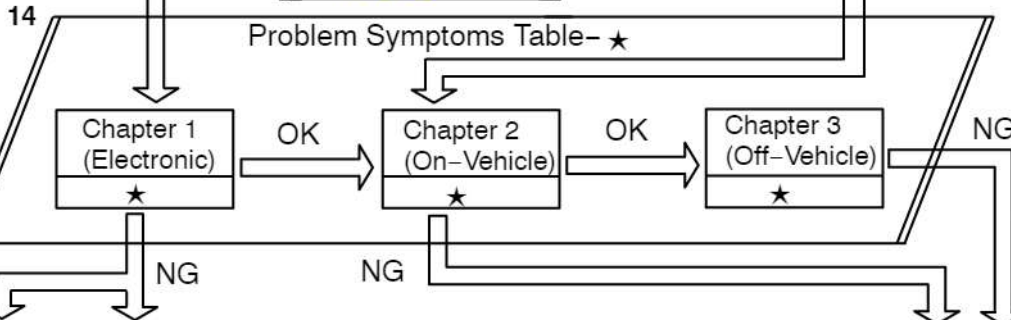

15 Circuit Inspection ★
• Pattern Select Switch Circuit Check
• A/T.P. Indicator Circuit Check

16 Parts Inspection

17 Identification of Problem → 18 Repair → Confirmation Test → End

cardiagn.com

When using hand-held tester, troubleshoot in accordance with the procedure on the following pages.

Items inside  are titles of pages in this manual, with the page number indicated in the bottom portion. See the indicated pages for detailed explanations.

★: Refer LAND CRUISER Chassis and Body Repair Manual Supplement (Pub. No. RM970E).

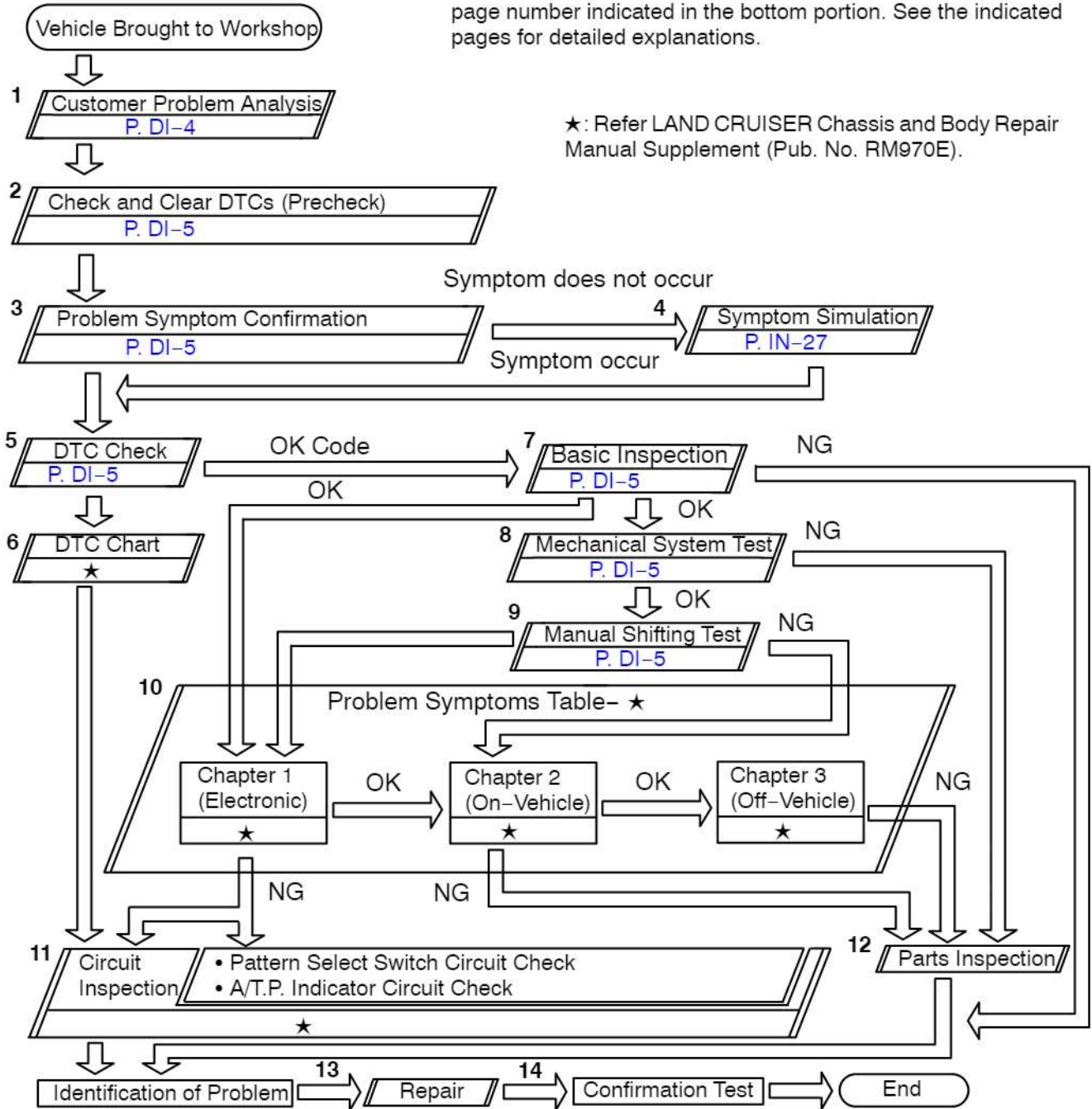

PRECAUTION

NOTICE:

Perform the **RESET MEMORY (AT initialization)** when replacing the automatic transmission assy, engine assy or the ECM (See page DI-5).

HINT:

Initialization can not be completed by only disconnecting the battery terminal.



CUSTOMER PROBLEM ANALYSIS CHECK

Automatic Transmission
System Check Sheet

Inspector's
Name _____

Customer's Name		Registration No.	
		Registration Year	/ /
		Frame No.	
Date Vehicle Brought In	/ /	Odometer Reading	km mile

Date Problem Occurred	/ /
How Often Does Problem Occur?	<input type="checkbox"/> Continuous <input type="checkbox"/> Intermittent (_____ times a day)

Symptoms	<input type="checkbox"/> Vehicle does not move (<input type="checkbox"/> Any range <input type="checkbox"/> particular range)
	<input type="checkbox"/> No up-shift (<input type="checkbox"/> 1st → 2nd <input type="checkbox"/> 2nd → 3rd <input type="checkbox"/> 3rd → 4th <input type="checkbox"/> 4th → 5th)
	<input type="checkbox"/> No down-shift (<input type="checkbox"/> 5th → 4th <input type="checkbox"/> 4th → 3rd <input type="checkbox"/> 3rd → 2nd <input type="checkbox"/> 2nd → 1st)
	<input type="checkbox"/> Lock-up malfunction
	<input type="checkbox"/> Shift point too high or too low
	<input type="checkbox"/> Harsh engagement (<input type="checkbox"/> N → D <input type="checkbox"/> Lock-up <input type="checkbox"/> Any drive range)
	<input type="checkbox"/> Slip or shudder
	<input type="checkbox"/> No kick-down
<input type="checkbox"/> Others (_____)	

Check Item	Malfunction Indicator Lamp	<input type="checkbox"/> Normal <input type="checkbox"/> Remains ON
------------	----------------------------	---

DTC Check	1st Time	<input type="checkbox"/> Normal code <input type="checkbox"/> Malfunction code (DTC _____)
	2nd Time	<input type="checkbox"/> Normal code <input type="checkbox"/> Malfunction code (DTC _____)

PRE-CHECK

1. DIAGNOSIS SYSTEM

(a) Description for Euro-OBD

- When troubleshooting Euro-OBD vehicles, the only difference from the usual troubleshooting procedure is that you connect the vehicle to the OBD scan tool complying with ISO 15031-4 or hand-held tester, and read off various data output from the vehicle's Engine and ECT ECU.
- Euro-OBD regulations require that the vehicle's on-board computer lights up the Check Engine Warning Light (Malfunction Indicator Lamp)/CHK ENG (MIL) on the instrument panel when the computer detects a malfunction in the emission control system/components or in the powertrain control components which affect vehicle emissions, or a malfunction in the computer. In addition to CHK ENG (MIL) lighting up when a malfunction is detected, the applicable Diagnostic Trouble Codes (DTCs) prescribed by ISO15031-6 are recorded in the Engine and ECT ECU memory (See Pub. No. RM970E, page DI-20).

If the malfunction code is not detected in 3 consecutive trips, CHK ENG (MIL) goes off automatically but the DTCs remain recorded in the Engine and ECT ECU memory.

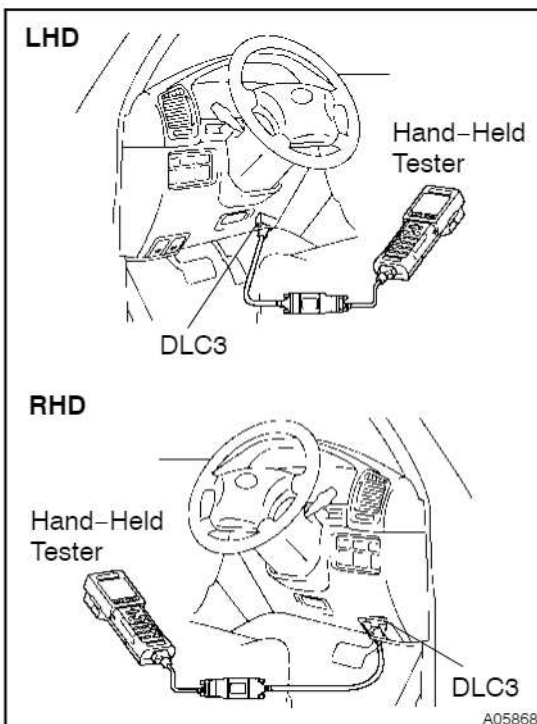

- To check the DTCs, connect the OBD scan tool or hand-held tester to the Data Link Connector 3 (DLC3) on the vehicle. The OBD scan tool or hand-held tester also enables you to erase the DTCs and check frozen frame data and various forms of engine data (For operating instructions, see the OBD scan tool's instruction book.).
- DTCs include ISO controlled codes and manufacturer controlled codes. ISO controlled codes must be set as prescribed by the ISO, while manufacturer controlled codes can be set freely by the manufacturer within the prescribed limits (See Pub. No. RM970E, page DI-20).

- The diagnosis system operates in normal mode during normal vehicle use. It also has a check mode for technicians to simulate malfunction symptoms and troubleshoot. Most DTCs use 2 trip detection logic* to prevent erroneous detection, and ensure thorough malfunction detection. By switching the Engine and ECT ECU to check mode when troubleshooting, the technician can cause the CHK ENG (MIL) to light up for a malfunction that is only detected once or momentarily (Hand-held tester only) (See step 2).
 - *2 trip detection logic:
When a malfunction is first detected, the malfunction code is temporarily stored in the Engine and ECT ECU memory (1st trip). If the same malfunction is detected again during the second drive test, this second detection causes the CHK ENG (MIL) to light up (2nd trip) (However, the ignition switch must be turned OFF between the 1st trip and the 2nd trip.).
- (b) Description for M-OBD
- When troubleshoot Multiplex OBD (M-OBD) vehicles, the only difference from the usual troubleshooting procedure is that you connect the vehicle to the hand-held tester, and read off various data output from the vehicle's Engine and ECT ECU.
 - The vehicle's on-board computer indicates the check engine light (CHK ENG) on the instrument panel when the computer detects a malfunction in the computer itself or in drive system components. In addition to an indication of the CHK ENG when a malfunction is detected, the applicable Diagnostic Trouble Codes (DTCs) are recorded in the Engine and ECT ECU memory (See Pub. No. RM970E, page DI-20).

If the malfunction code is not detected in 3 consecutive trips, CHK ENG (MIL) goes off automatically but the DTCs remain recorded in the Engine and ECT ECU memory.

- To check the DTCs, connect the hand-held tester to Data Link Connector 3 (DLC3) on the vehicle. or read the number of blinks of the check engine warning light when TC and CG terminals on the DLC3 are connected. The hand-held tester also enables you to erase the DTCs and activate the several actuators and check frozen frame data and various forms of engine data. (For operating instructions, see the hand-held tester instruction book.)

- The diagnosis system operates in the normal mode during normal vehicle use. It also has a check (test) mode for technicians to simulate malfunction symptoms and troubleshoot. Most DTCs use 2 trip detection logic* to prevent erroneous detection, and ensure thorough malfunction detection. By switching the Engine and ECT ECU to the check (test) mode using hand-held tester when troubleshooting, the technician can cause the CHK ENG on the light up for a malfunction that is only detected once or momentarily (Hand-held tester only) (See step 2).
- * 2 trip detection logic
When a logic malfunction is first detected, the malfunction is temporarily stored in the Engine and ECT ECU memory. If the same malfunction is detected again during the second drive test, this second detection causes the CHK ENG to light up.
The 2 trip repeats the same mode for 2 times (However, the ignition switch must be turned OFF between the 1st trip and 2nd trip).

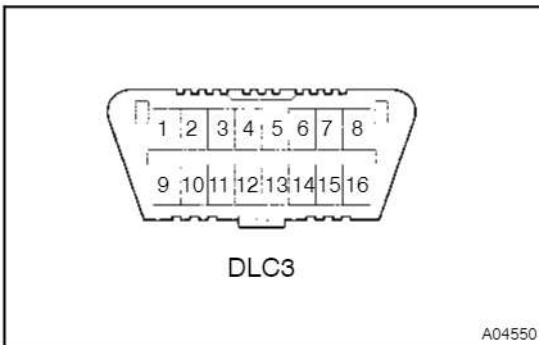

(c) Check the DLC3.

The vehicle's Engine and ECT ECU uses the ISO 9141-2 (Euro-OBD)/ISO 14230 (M-OBD) communication protocol. The terminal arrangement of DLC3 complies with ISO 15031-3 and matches the ISO 9141-2/ISO 14230 format.

Terminal No.	Connection/Voltage or Resistance	Condition
7	Bus + Line/Pulse generation	During communication
4	Chassis Ground \leftrightarrow Body Ground/1 Ω or less	Always
5	Signal Ground - Body Ground/1 Ω or less	Always
16	Battery Positive \leftrightarrow Body Ground/9 - 14 V	Always

HINT:

If your display shows UNABLE TO CONNECT TO VEHICLE when you have connected the cable of the hand-held tester to the DLC3, turned the ignition switch ON and operated the scan tool, there is a problem on the vehicle side or tool side.

If communication is normal when the tool is connected to another vehicle, inspect the DLC3 on the original vehicle.

If communication is still not possible when the tool is connected to another vehicle, the problem is probably in the tool itself, so consult the Service Department listed in the tool's instruction manual.

2. INSPECT DIAGNOSIS (Normal Mode)

(a) Check the DTC using hand-held tester.

NOTICE:**Hand-held tester only:**

When the diagnosis system is switched from the normal mode to the check mode, it erases all DTCs and frozen frame data recorded in the normal mode. So before switching modes, always check the DTCs and frozen frame data, and note them down.

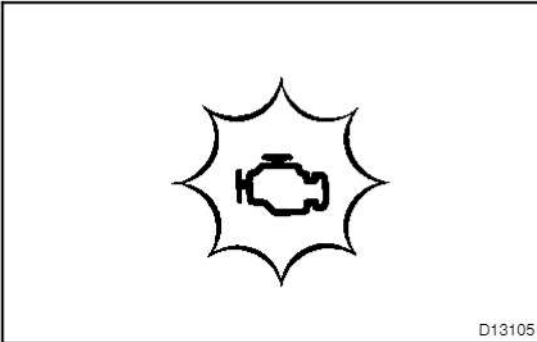

- (1) The CHK ENG (MIL) comes on when the ignition switch is turned ON and the engine is not running.
- (2) Prepare the hand-held tester.
- (3) Connect the hand-held tester to the DLC3.
- (4) Turn the ignition switch ON and push the hand-held tester main switch ON.
- (5) Use the hand-held tester to check the DTCs and frozen frame data, note them down (For operating instructions, see the hand-held tester instruction book.).
- (6) See Pub. No. RM970E, page DI-20 to confirm the details of the DTCs.

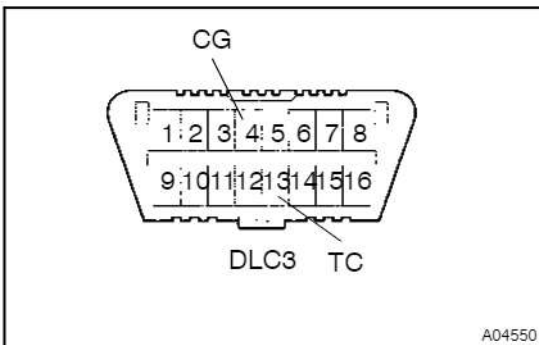

(b) Check the DTC when not using hand-held tester (M-OBD).

HINT:

Middle East leaded gasoline type only

- (1) Turn the ignition switch ON, but do not start the engine.
 - (2) Using SST, connect terminals 13 (TC) and 4 (CG) of DLC3.
- SST 09843-18040

- (3) Read the DTC indicated by the number of times the MIL blinks.

HINT:

If the system is operating normally, the light will blink 2 times per second.

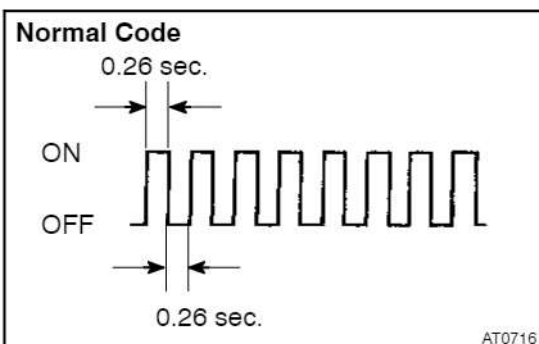

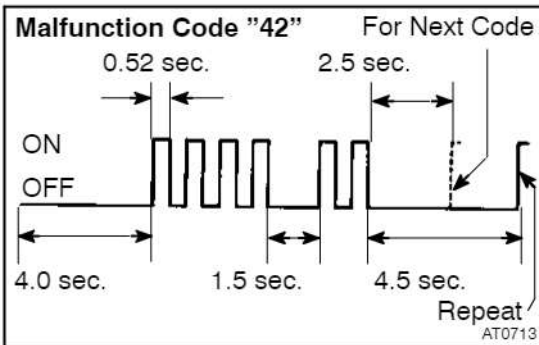

- (4) The malfunction code is indicated, as shown in the chart on the left (DTC "42" is shown as an example).

HINT:

When 2 or more malfunction codes are stored in memory, the lower-numbered code is displayed first.

3. INSPECT DIAGNOSIS (Check (Test) Mode)

HINT:

Hand-held tester only:

Compared to the normal mode, the check mode has an increased sensitivity to detect malfunctions.

Furthermore, the same diagnostic items which are detected in the normal mode can also be detected in the check (test) mode.

- (a) Check the DTC.
- (1) Initial conditions
 - Battery voltage 11 V or more
 - Throttle valve fully closed
 - Transmission in P or N range
 - A/C switched OFF
 - (2) Turn the ignition switch OFF.
 - (3) Prepare the hand-held tester.

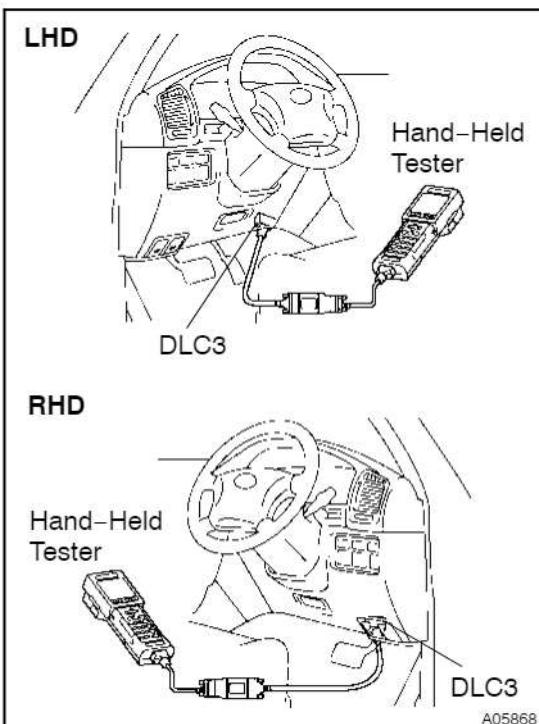

- (4) Connect the hand-held tester to the DLC3.
- (5) Turn the ignition switch ON and push the hand-held tester main switch ON.

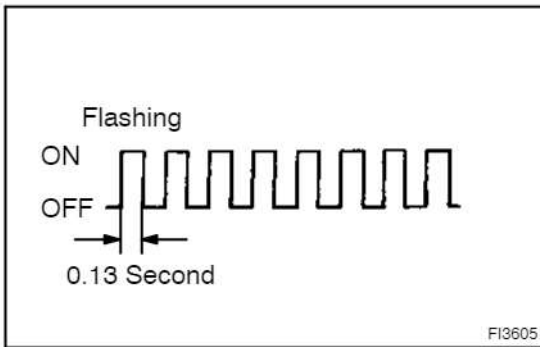

- (6) Switch the hand-held tester from the normal mode to the check (test) mode.
- (7) Check if the CHK ENG (MIL) blinks.

NOTICE:

If the hand-held tester switches the Engine and ECT ECU from the normal mode to the check mode or vice-versa, or if the ignition switch is turned from ON to ACC or OFF during the check mode, the DTCs and freeze frame data will be erased.

- (8) Start the engine (MIL goes out after the engine starts).
- (9) Simulate the conditions of the malfunction described by the customer.

NOTICE:

Leave the ignition switch ON until you have checked the DTCs, etc.

- (10) After simulating the malfunction conditions, use the hand-held tester diagnosis selector to check the DTCs and freeze frame data, etc.

HINT:

Take care not to turn the ignition switch OFF. Turning the ignition switch OFF switches the diagnosis system from the check (test) mode to the normal mode. so all DTCs, etc. are erased.

- (11) After checking the DTC, inspect the applicable circuit.
- (b) Clear the DTC.
The DTCs and freeze frame data will be erased by either actions.
- (1) Operating the hand-held tester to erase the codes. (See the hand-held tester's instruction book for operating instructions.)
 - (2) Disconnecting the battery terminals or EFI fuse and ETCS fuse more than 60 second.

4. DATA LIST

HINT:

According to the DATA LIST displayed by the Hand-held tester, you can read the value of the switch, sensor, actuator and so on without parts removal. Reading the DATA LIST as a first step of troubleshooting is one of the method to shorten the labor time.

- (a) Warm up the engine.
- (b) Turn the ignition switch OFF.
- (c) Connect the Hand-held tester to the DLC3.
- (d) Turn the ignition switch ON.
- (e) Push the "ON" button of Hand-held tester.
- (f) Select the item "/ DIAGNOSIS / OBD/MOBD / DATA LIST / ALL (or ATM)".
- (g) According to the display on tester, read the "DATA LIST".

Item	Measurement Item/ Display (Range)	Normal Condition	Diagnostic Note
STOP LIGHT SW	Stop light SW Status/ ON or OFF	<ul style="list-style-type: none"> • Brake Pedal is depressed: ON • Brake Pedal is released: OFF 	←
SHIFT	Actual Gear range/ 1st, 2nd, 3rd, 4th or 5th	Shift Lever range is; <ul style="list-style-type: none"> • L: 1st • 2: 1st or 2nd • 3: 1st, 2nd or 3rd • 4: 1st, 2nd, 3rd or 4th • D: 1st, 2nd, 3rd, 4th or 5th 	←
PNP SW [NSW]	PNP SW Status/ ON or OFF	Shift lever range is; P or N: ON Except P or N: OFF	The shift lever range and these values are different, there are failures of the PNP switch or shift cable adjustment.
REVERSE	PNP SW Status/ ON or OFF	Shift lever range is; R: ON Except R: OFF	
DRIVE	PNP SW Status/ ON or OFF	Shift lever range is; D and 4: ON Except D and 4: OFF	
4th/DRIVE	PNP SW Status/ ON or OFF	Shift lever range is; 4: ON Except 4: OFF	
3RD	PNP SW Status/ ON or OFF	Shift lever range is; 3: ON Except 3: OFF	
2ND	PNP SW Status/ ON or OFF	Shift lever range is; 2 and L: ON Except 2 and L: OFF	
LOW	PNP SW Status/ ON or OFF	Shift lever range is; L: ON Except L: OFF	
LOCK UP SOL	Lock Up Solenoid Status/ ON or OFF	<ul style="list-style-type: none"> • Lock Up: ON • Except Lock Up: OFF 	←
PATTERN SW (M)	Pattern SW (PWR) Status/ ON or OFF	Pattern SW (PWR) is; Pushed in: ON Pushed once again: OFF	←
SNOW SW	Pattern SW (2nd) Status/ ON or OFF	<ul style="list-style-type: none"> • IG SW ON: OFF <li style="text-align: center;">↓ • Pattern SW (2nd) Push: ON <li style="text-align: center;">↓ • Pattern SW (2nd) Push: OFF 	←
SOLENOID (SLT)	Shift Solenoid SLT Status/ ON or OFF	IG SW ON: ON	←

SOLENOID (SLU)	Shift Solenoid SLU Status/ ON or OFF	• Lock Up: ON • Except Lock Up: OFF	←
SPD (SP2)	Counter Gear Speed display/ min.: 0 km/h (0 mph) max.: 255 km/h (158 mph)	Vehicle stopped: 0 km/h (0 mph)	←
AT FLUID TEMP	ATF Temp. Sensor No. 1 Value/ min.: -40°C (-40°F) max.: 215°C (419°F)	80°C (176°F) (After Stall Test)	If the value is "-40°C (-40°F)" or "215°C (419°F)", ATF temp. sensor No. 1 circuit is opened or shorted.

5. ACTIVE TEST

HINT:

Performing the ACTIVE TEST using the Hand-held tester allows the relay, VSV, actuator and so on to operate without parts removal. Performing the ACTIVE TEST as a first step of troubleshooting is one of the method to shorten the labor time.

It is possible to display the DATA LIST during the ACTIVE TEST.

- Warm up the engine.
- Turn the ignition switch OFF.
- Connect the Hand-held tester to the DLC3.
- Turn the ignition switch ON.
- Push the "ON" button of Hand-held tester.
- Select the item "/ DIAGNOSIS / OBD/MOBD / ACTIVE TEST".
- According to the display on tester, perform the "ACTIVE TEST".

Item	Test Details	Diagnostic Note
SHIFT	[Test Details] Operate the shift solenoid valve and set the each shift range by yourself. [Vehicle Condition] Less than 50 km/h (31 mph) [Others] • Press → button: Shift up • Press ← button: Shift down	Possible to check the operation of the shift solenoid values. HINT: Shifting to the 5th gear is possible only when the vehicle stops or idle is ON.
LOCK UP	[Test Details] Control the shift solenoid SLU to set the ATM to the lock-up condition. [Vehicle Condition] Vehicle Speed: 58 km/h (36 mph) or more	Possible to check the SLU operation.
LINE PRESS UP	[Test Details] Operate the shift solenoid SLT and raise the line pressure. [Vehicle Condition] • Vehicle Stopped. • IDL: ON [Others] ON: Line pressure up. OFF: No action (normal operation)	-

6. PROBLEM SYMPTOM CONFIRMATION

Taking into consideration the results of the customer problem analysis, try to reproduce the symptoms of the trouble. If the problem is that the transmission does not up-shift, down-shift, or the shift point is too high or too low, conduct the following road test to confirm the automatic shift schedule and simulate the problem symptoms.

7. ROAD TEST

NOTICE:

Perform the test at normal operating ATF temperature 50 – 80 °C (122 – 176 °F).

(a) D range test (NORM and PWR pattern):

Shift into the D range and fully depress the accelerator pedal and check the following points.

(1) Check up-shift operation.

Check that 1 → 2, 2 → 3, 3 → 4 and 4 → 5th up-shifts take place, and that the shift points conform to the automatic shift schedule (See Pub. No. RM970E, page SS-4).

HINT:

- 5th Gear Up-shift Prohibition Control (1. Coolant temp. is 55 °C (131 °F) or less. 2. Vehicle speed is 51 km/h (32 mph) or less.)
- 4th Gear Up-shift Prohibition Control (1. Coolant temp. is 40 °C (104 °F) or less. 2. Vehicle speed is 45 km/h (28 mph) or less.)
- 5th Gear Lock-up Prohibition Control (1. Brake pedal is depressed. 2. Coolant temp. is 60 °C (140 °F) or less.)
- When the 2nd start switch is on, there is no 1→2 up-shift and 2→1 down-shift.
 - (2) Check for shift shock and slip.
Check for shock and slip at the 1 → 2, 2 → 3, 3 → 4 and 4 → 5th up-shifts.
 - (3) Check for abnormal noises and vibration.
Drive in the D range lock-up or 5th gear and check for abnormal noises and vibration.

HINT:

The check for the cause of abnormal noises and vibration must be done very thoroughly as it could also be due to loss of balance in the differential, torque converter clutch, etc.

(4) Check kick-down operation.

While running in the D range, 2nd, 3rd, 4th and 5th gears, check that the possible kick-down vehicle speed limits for 2 → 1, 3 → 2, 4 → 3 and 5th → 4 kick-downs conform to those indicated on the automatic shift schedule (See Pub. No. RM970E, page SS-4).

(5) Check abnormal shock and slip at kick-down.

(6) Check the lock-up mechanism.

- Drive in D range 5th gear, at a steady speed (lock-up ON) of about 70 km/h (43 mph).
- Lightly depress the accelerator pedal and check that the engine speed does not change abruptly.

If there is a big jump in engine speed, there is no lock-up.

(b) 4 range test:

Shift into the 4 range and fully depress the accelerator pedal and check the following points.

(1) Check up-shift operation.

Check that the 1 → 2, 2 → 3 and 3 → 4 up-shift takes place and that the shift point conforms to the automatic shift schedule (See Pub. No. RM970E, page SS-4).

HINT:

- There is no 5th up-shift in the 4 range.
- 4th Gear Lock-up Prohibition Control (1. Brake pedal is depressed. 2. Coolant temp. is 60 °C (140 °F) or less.)
 - (2) Check engine braking.
While driving in the 4 range and 4th gear, release the accelerator pedal and check the engine braking effect.
 - (3) Check for abnormal noises during acceleration and deceleration, and for shock at up-shift and down-shift.

- (4) Check the lock-up mechanism.
 - Drive in 4 range 4th gear, at a steady speed (lock-up ON) of about 64 km/h (40 mph).
 - Lightly depress the accelerator pedal and check that the engine speed does not change abruptly.

If there is a big jump in engine speed, there is no lock-up.

(c) 3 range test:

Shift into the 3 range and fully depress the accelerator pedal and check the following points.

- (1) Check up-shift operation.
Check that the 1 → 2 and 2 → 3 up-shift takes place and that the shift point conforms to the automatic shift schedule (See Pub. No. RM970E, page SS-4).
- (2) Check engine braking.
While running in the 3 range and 3rd gear, release the accelerator pedal and check the engine braking effect.
- (3) Check for abnormal noises during acceleration and deceleration, and for shock at up-shift and down-shift.

(d) 2 range test:

Shift into the 2 range and fully depress the accelerator pedal and check the following points.

- (1) Check up-shift operation.
Check that the 1 → 2 up-shift takes place and that the shift point conforms to the automatic shift schedule (See Pub. No. RM970E, page SS-4).

HINT:

When the 2nd start switch is ON, there is no 1 → 2 up-shift and 2 → 1 down-shift.

- (2) Check engine braking.
While running in the 2 range and 2nd gear, release the accelerator pedal and check the engine braking effect.
- (3) Check for abnormal noises during acceleration and deceleration, and for shock at up-shift and down-shift.

(e) L range test:

Shift into the L range and fully depress the accelerator pedal and check the following points.

- (1) Check no up-shift.
While running in the L range, check that there is no up-shift to 2nd gear.
- (2) Check engine braking.
While running in the L range, release the accelerator pedal and check the engine braking effect.
- (3) Check for abnormal noises during acceleration and deceleration.

(f) R range test:

Shift into the R range and fully depress the accelerator pedal and check for slipping.

CAUTION:

Before conducting this test ensure that the test area is free from people and obstruction.

(g) P range test:

Stop the vehicle on a grade (more than 5°) and after shifting into the P range, release the parking brake. Then, check that the parking lock pawl holds the vehicle in place.

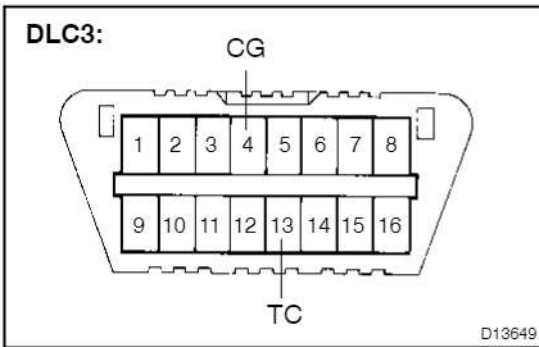

8. BASIC INSPECTION

- (a) Check the fluid level.
- (1) Using an SST, short-circuit between terminals TC and CG of the DLC3.
- SST 09843-18040
- (2) Start the engine and run at idle.
 - A/C switch must be turned off.
 - On the model with the active height control suspension & adaptive variable suspension, turn the height control switch off.
 - (3) Slowly move the shift lever through all the ranges from P to L, and move it back to the P range.
 - (4) Move the shift lever from the N to the D range, or from D to N, within 1.5 seconds. Perform the above procedure for 6 seconds or more. This will activate the oil temperature detection mode.

Standard: The A/T OIL TEMP warning light comes on for 2 seconds and then goes off.

- (5) Return the shift lever to the P range and disconnect terminal TC and CG.
- (6) Idle the engine to raise the oil temperature.
- (7) Lift up the vehicle right after the meter indicator light "ATF temperature warning light" comes on.
 - The A/T OIL TEMP warning light indicates the ATF temperature according to the following table.

ATF Temp.	Less than optimized temperature	Optimized temperature	More than optimized temperature
A/T OIL TEMP warning light	OFF	ON	Blinking

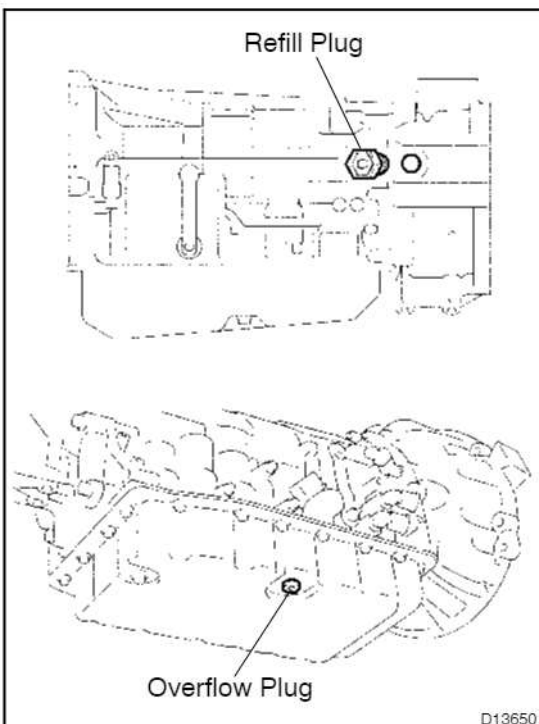

- (8) Remove the overflow plug and check the fluid level.

Standard:

When ATF overflows *	ATF level is higher than the specification (Go to step (11))
When ATF does not overflow	ATF level is equal to or lower than specification (Go to step (9))

*: Since the overflow capacity is 3 cc, check if the drained ATF is 3 cc or more.

- (9) Remove the refill plug.
- Fluid type: AUTO FLUID WS**
- (10) Fill ATF to the refill plug until it flows out from the overflow plug.
 - (11) When the draining ATF becomes a trickle, install the overflow plug through a new gasket.
 - (12) Install the refill plug (only if the refill plug has been removed).
 - (13) Lower the vehicle down.
 - (14) Turn the ignition switch off to stop the engine.

- (b) Check the fluid condition.
If the fluid smells burnt or is black, replace it (see step 9.).

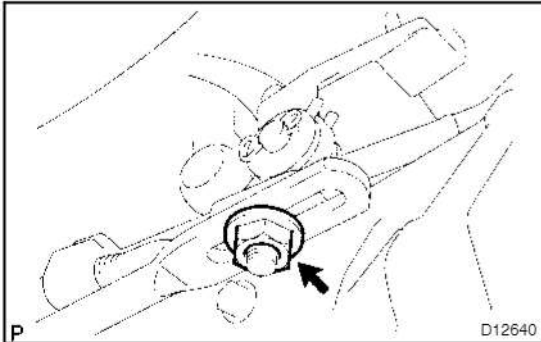

- (c) Inspect and adjust the shift lever range.
When shifting the shift lever from the N range to other ranges, check that the lever can be shifted smoothly and accurately to each range and that the range indicator is not aligned with the correct range.

If the indicator is not aligned with the correct range, carry out the following adjustment procedures.

- (1) Loosen the nut on the shift lever.
- (2) Push the control shaft fully rearward.
- (3) Return the control shaft lever 2 notches to N range.
- (4) Set the shift lever to N range.
- (5) While holding the shift lever lightly toward the R range side, tighten the shift lever nut.

Torque: 13 N·m (130 kgf·cm, 9 ft·lbf)

- (6) Start the engine and make sure that the vehicle moves forward when shifting the lever from the N to D range and reverses when shifting it to the R range.

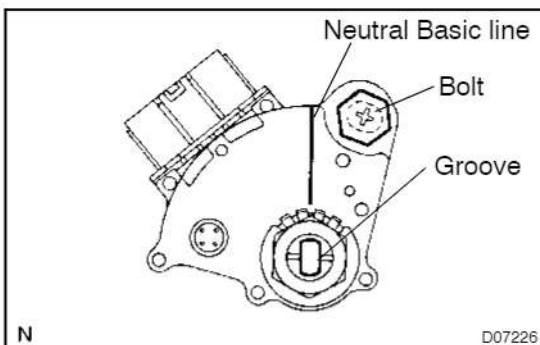
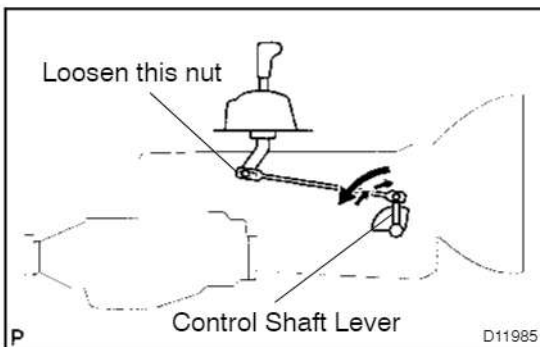

- (d) Inspect and adjust the neutral start switch.
- Check that the engine can be started with the shift lever only in the N or P range, but not in other ranges.

If it is not as stated above, carry out the following adjustment procedures.

- Loosen the neutral start switch bolt and set the shift lever to the N range.
- Align the groove with neutral basic line.
- Hold in range and tighten the bolt.

Torque: 13 N·m (130 kgf·cm, 9 ft·lbf)

- For continuity inspection of the neutral start switch, (See Pub. No. RM970E, page DI-32).

- (e) Check the idle speed.

Idle speed (In N range and air conditioner OFF):

700 ± 50 rpm

9. ADD AUTOMATIC TRANSMISSION FLUID

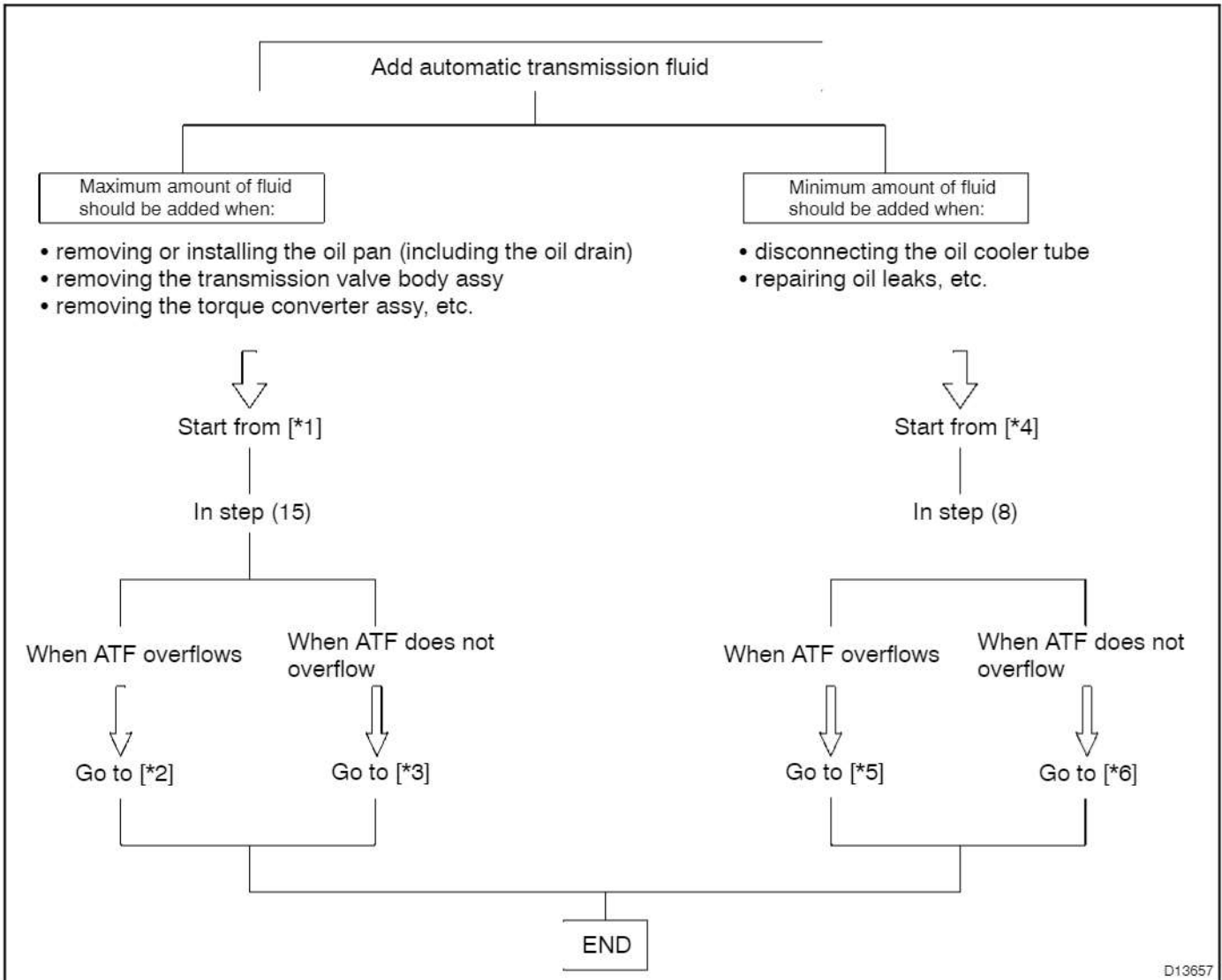

- (a) When adding a maximum amount of fluid: [*1]
 (1) Lift the vehicle while keeping it level.

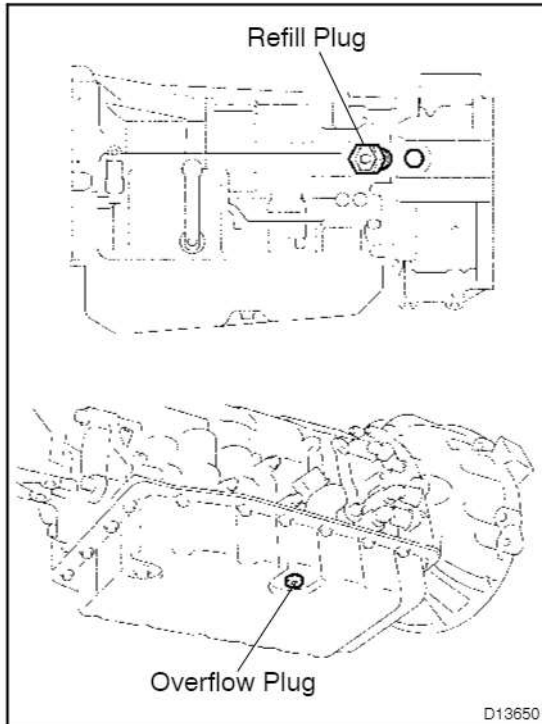

- (2) Remove the refill plug and overflow plug.

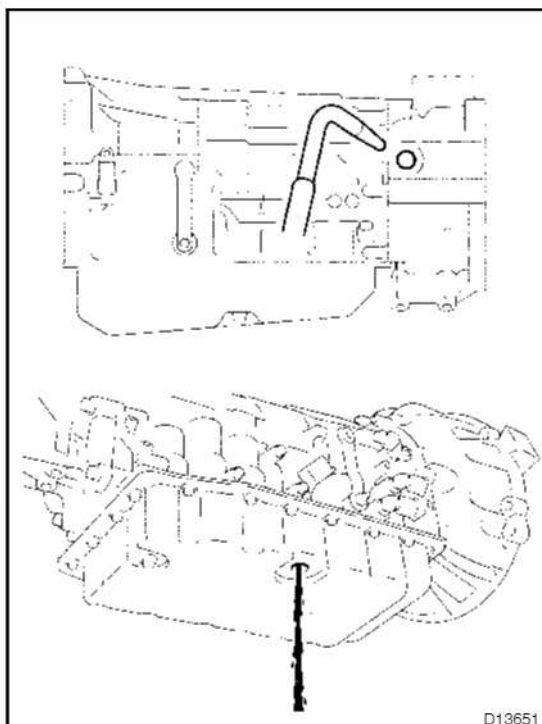

- (3) Add ATF to the refill hole until it drains out from the overflow hole.

NOTICE:
Be sure to add ATF WS.

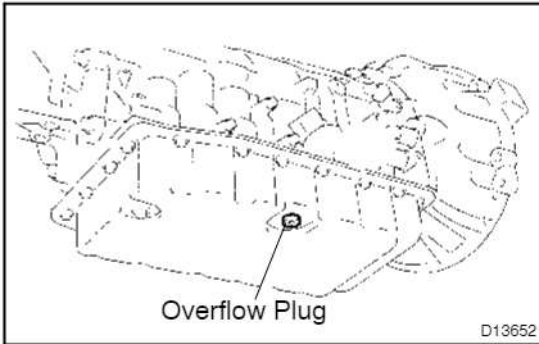

- (4) Temporarily install the gasket and overflow plug.
Torque: 20 N·m (204 kgf·cm, 15 ft·lbf)
- (5) Add proper amount of ATF to the refill hole.

NOTICE:

Refill amount is different depending on the related procedures.

Related procedures	Refill amount
Removal and installation of oil pan	1.7 liters (1.8 us qts, 1.5 Imp.qts)
Removal of transmission valve body assy	4.3 liters (4.5 us qts, 3.8 Imp.qts)
Removal of torque converter assy	5.4 liters (5.7 us qts, 4.8 Imp.qts)

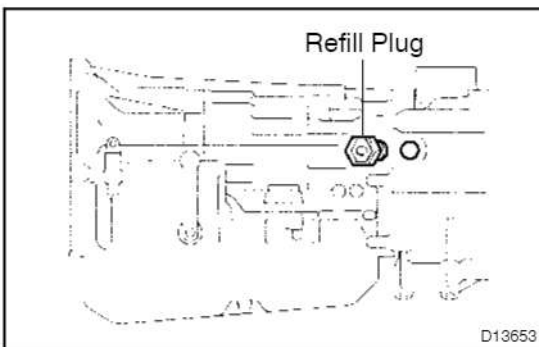

- (6) Temporarily install the O-ring and refill plug.
Torque: 39 N·m (400 kgf·cm, 29 ft·lbf)
- (7) Lower down the vehicle.

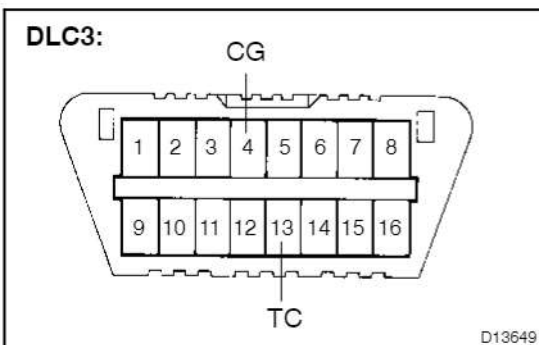

- (8) Using an SST, short-circuit between terminals TC and CG of the DLC3.
SST 09843-18040
- (9) Start the engine and run at idle.

NOTICE:

A/C switch must be turned off.

- (10) Slowly move the shift lever from the P to the 2-L range.
Return the shift lever to the P range.
- (11) Switch to the fluid temperature detection mode.
 - Move the shift lever from the N to the 4D range, or from 4D to N, within 1.5 seconds.
 - Perform the above procedure for 6 seconds or more.

Standard: Meter indicator light "ATF temperature warning light" comes on for 2 seconds and then goes off.

- (12) Disconnect terminals TC and CG after confirming the above condition.



(13) Idle the engine to raise fluid temperature.

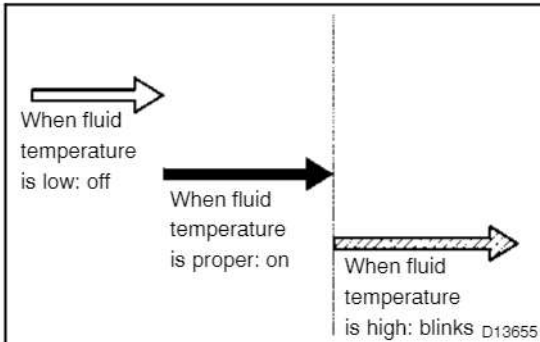

(14) Lift up the vehicle right after the meter indicator light "ATF temperature warning light" comes on.

NOTICE:

- **Add fluid only when the meter indicator light is on.**
- **Perform the procedure while the engine is idling.**

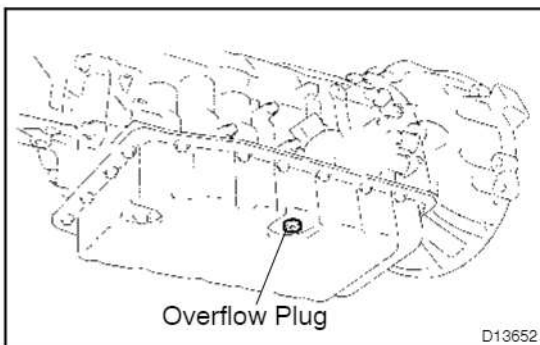

(15) Remove the overflow plug. If ATF overflows, proceed to [*2].

If ATF does not overflow, proceed to [*3].

HINT:

"Overflow" indicates the condition that ATF drains out from the overflow tube.

NOTICE:

Capacity of the overflow tube is approximately 3 cc.

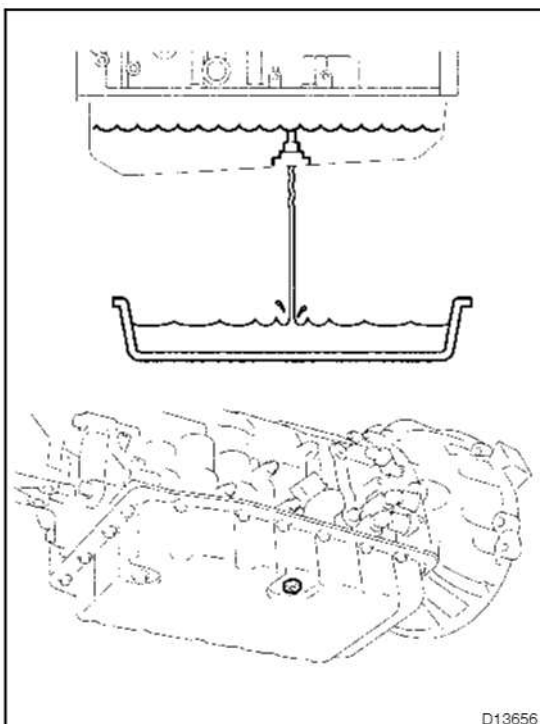

(b) When fluid overflows: [*2]

(1) Install the overflow plug through a new gasket when the draining ATF becomes a trickle.

Torque: 20 N·m (204 kgf·cm, 15 ft·lbf)

(2) Install the refill plug through a new O-ring.

Torque: 39 N·m (400 kgf·cm, 29 ft·lbf)

(3) Lower down the vehicle.

(4) Turn the ignition switch off.

(5) Check the fluid leaks.

Check for leaks in the transmission.

If there are leaks, it is necessary to repair or replace O-rings, FIGs, oil seals, plugs or other parts.

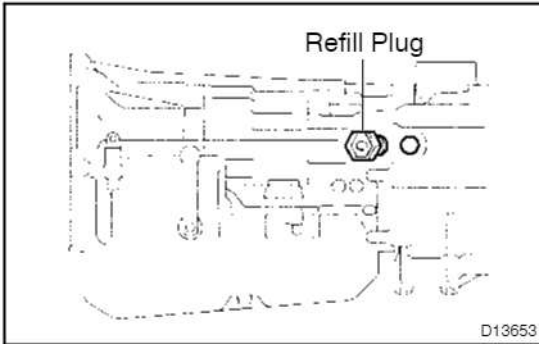

(c) When fluid does not overflow: [*3]

(1) Remove the refill plug.

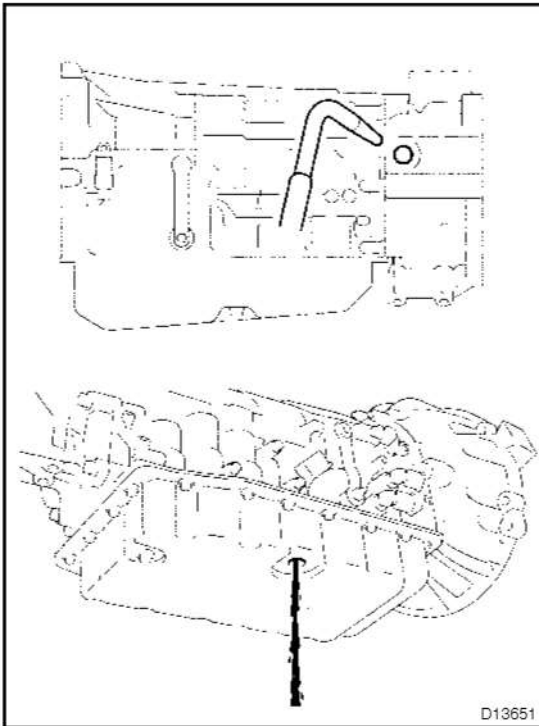

(2) Add ATF to the refill hole until it drains out from the overflow hole.

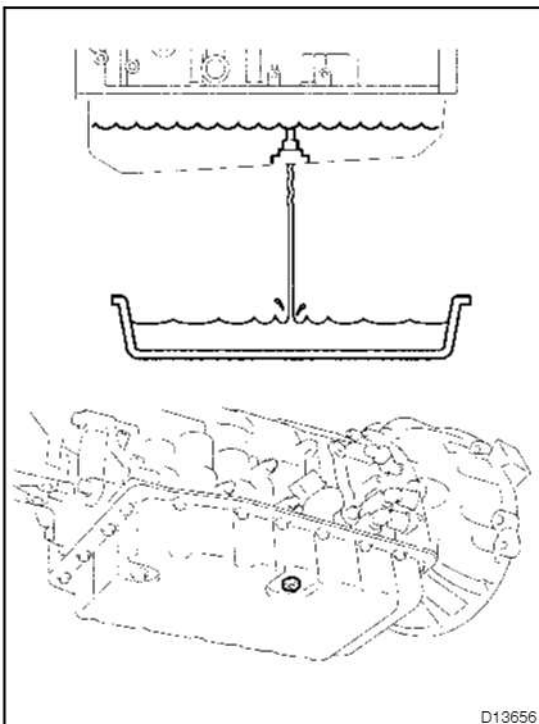

(3) Install the overflow plug through a new gasket when the draining ATF becomes a trickle.

Torque: 20 N·m (204 kgf·cm, 15 ft·lbf)

(4) Install the refill plug through a new O-ring.

Torque: 39 N·m (400 kgf·cm, 29 ft·lbf)

(5) Lower down the vehicle.

(6) Turn the ignition switch off.

(7) Check the fluid leaks.

Check for leaks in the transmission.

If there are leaks, it is necessary to repair or replace O-rings, FIGs, oil seals, plugs or other parts.

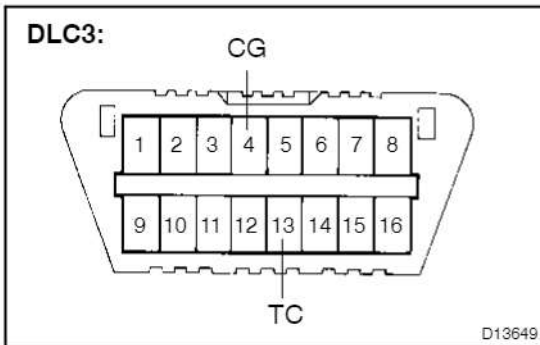

- (d) When adding a minimum amount of fluid: [*4]
- (1) Using an SST, short-circuit between terminals TC and CG of the DLC3.
- SST 09843-18040
- (2) Start the engine and run at idle.

NOTICE:**A/C switch must be turned off.**

- (3) Slowly move the shift lever from the P to the 2-L range. Return the shift lever to the P range.
- (4) Switch to the fluid temperature detection mode.
 - Move the shift lever from the N to the 4D range, or from 4D to N, within 1.5 seconds.
 - Perform the above procedure for 6 seconds or more.

Standard: Meter indicator light "ATF temperature warning light" comes on for 2 seconds and then goes off.

- (5) Disconnect terminals TC and CG after confirming the above condition.
- (6) Idle the engine to raise fluid temperature.

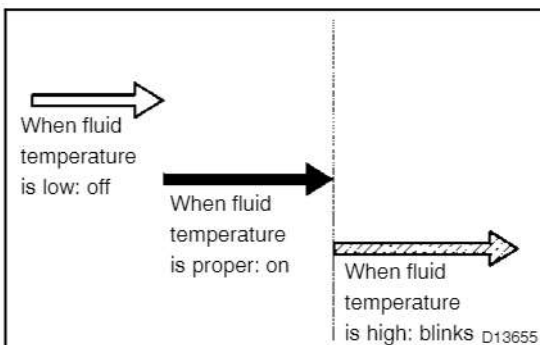

- (7) Lift up the vehicle right after the meter indicator light "ATF temperature warning light" comes on.

NOTICE:

- **Add fluid only when the meter indicator light is on.**
- **Perform the procedure while the engine is idling.**

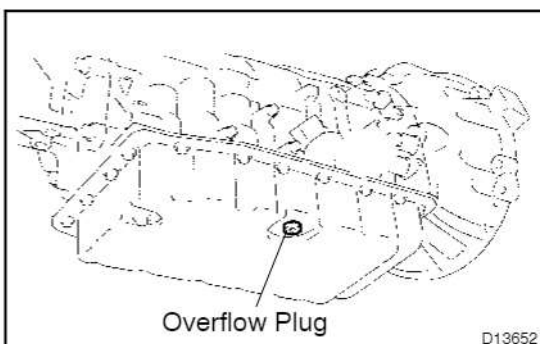

- (8) Remove the overflow plug. If ATF overflows, proceed to [*5]. If ATF does not overflow, proceed to [*6].

HINT:

"Overflow" indicates the condition that ATF drains out from the overflow tube.

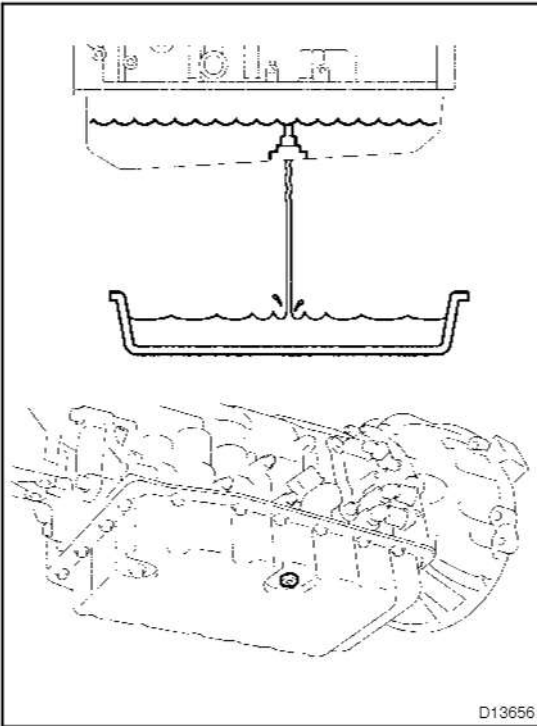

- (e) When fluid overflows: [*5]
 (1) Install the overflow plug through a new gasket when the draining ATF becomes a trickle.

Torque: 20 N·m (204 kgf·cm, 15 ft·lbf)

- (2) Install the refill plug through a new O-ring.

Torque: 39 N·m (400 kgf·cm, 29 ft·lbf)

- (3) Lower down the vehicle.
 (4) Turn the ignition switch off.
 (5) Check the fluid leaks.

Check for leaks in the transmission.

If there are leaks, it is necessary to repair or replace O-rings, FIPGs, oil seals, plugs or other parts.

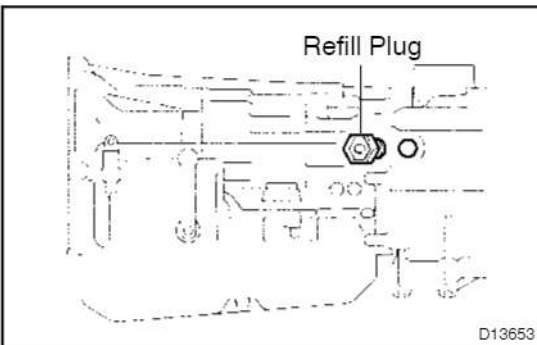

- (f) When fluid does not overflow: [*6]

- (1) Remove the refill plug.

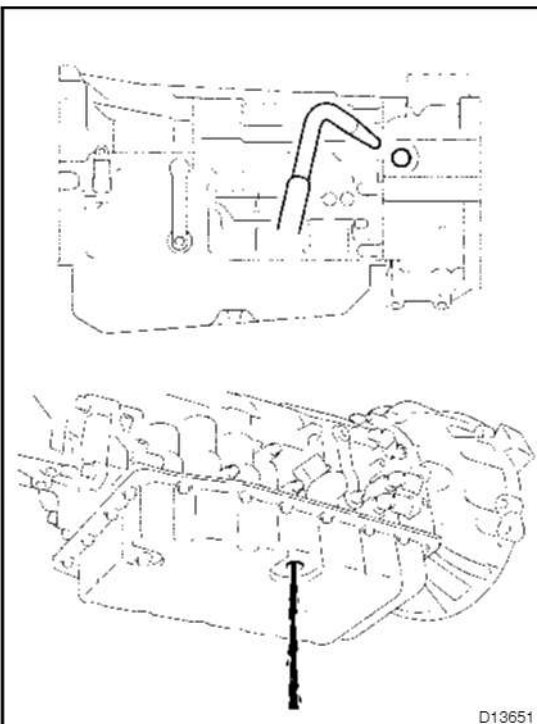

- (2) Add ATF to the refill hole until it drains out from the overflow hole.

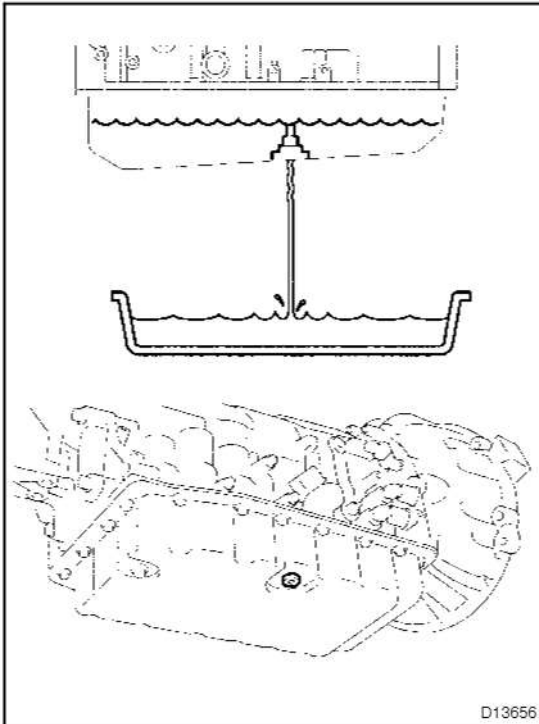

- (3) Install the overflow plug through a new gasket when the draining ATF becomes a trickle.

Torque: 20 N·m (204 kgf·cm, 15 ft·lbf)

- (4) Install the refill plug through a new O-ring.

Torque: 39 N·m (400 kgf·cm, 29 ft·lbf)

- (5) Lower down the vehicle.
- (6) Turn the ignition switch off.
- (7) Check the fluid leaks.

Check for leaks in the transmission.

If there are leaks, it is necessary to repair or replace O-rings, FIPGs, oil seals, plugs or other parts.

10. MECHANICAL SYSTEM TESTS

- (a) Measure the stall speed.

The object of this test is to check the overall performance of the transmission and engine by measuring the stall speeds in the D and R ranges.

NOTICE:

- Do the test at normal operating fluid temperature 70 – 80°C (158 – 176°F).
- Do not continuously run this test longer than 5 seconds.
- To ensure safety, conduct this test in a wide, clear level area which provides good traction.
- The stall test should always be carried out in pairs. One technician should observe the conditions of wheels or wheel stoppers outside the vehicle while the other is doing the test.

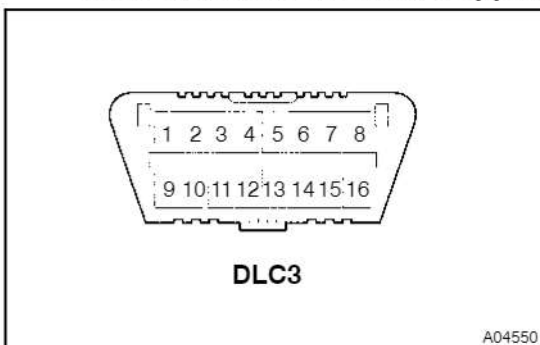

- (1) Chock the 4 wheels.
- (2) Connect a hand-held tester to DLC3 or tachometer to terminal TAC (9) of DLC3 with SST.

SST 09843-18030

- (3) Fully apply the parking brake.
- (4) Keep your left foot pressing firmly on the brake pedal.
- (5) Start the engine.
- (6) Shift into the D range. Press all the way down on the accelerator pedal with your right foot. Quickly read the stall speed at this time.

Stall speed: 2,150 ± 150 rpm

- (7) Do the same test in R range.

Stall speed: 2,150 ± 150 rpm

Evaluation:

Problem	Possible cause
(a) Stall speed low in D and R ranges	<ul style="list-style-type: none"> • Engine output may be insufficient • Stator one-way clutch is not operating properly HINT: If the value is larger or smaller than the specified value by 600 rpm or more, the torque converter could be faulty.
(b) Stall speed high in D range	<ul style="list-style-type: none"> • Line pressure too low • Clutch No. 1 (C₁) slipping • One-way clutch No.3 (F₃) not operating properly
(c) Stall speed high in R range	<ul style="list-style-type: none"> • Line pressure too low • Brake No. 4 (B₄) slipping • Clutch No. 3 (C₃) slipping • One-way clutch No.1 (F₁) not operating properly
(d) Stall speed high in D and R ranges	<ul style="list-style-type: none"> • Line pressure too low • Improper fluid level

(b) Measure the time lag.

When the shift lever is shifted while the engine is idling, there will be a certain time lapse or lag before the shock can be felt. This is used for checking the condition of the clutch and brake.

NOTICE:

- **Do the test at normal operating fluid temperature 70 – 80°C (158 – 176°F).**
- **Be sure to allow 1 minute interval between tests.**
- **Take 3 measurements and take the average value.**

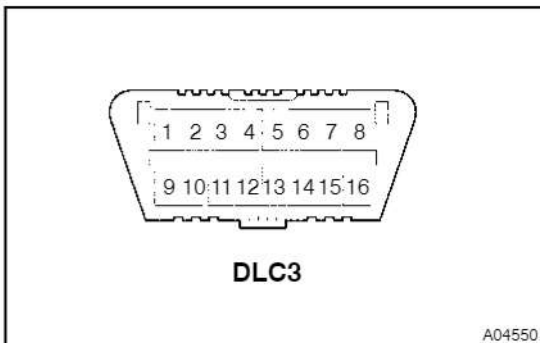

- (1) Fully apply the parking brake.
- (2) Connect a hand-held tester to DLC3 or tachometer to terminal TAC (9) of DLC3 with SST.

SST 09843-18030

- (3) Start the engine and check idle speed.

Idle speed (In N range and air conditioner OFF): 700 ± 50 rpm.

- (4) Shift the shift lever from N to D range. Using a stop watch, measure the time from when the lever is shifted until the shock is felt.

Time lag:

N → D Less than 1.2 seconds

- (5) In the same manner, measure the time lag for N → R.

Time lag:

N → R Less than 1.5 seconds

Evaluation (If N → D time or N → R time lag is longer than the specified):

Problem	Possible cause
N → D time lag is longer	<ul style="list-style-type: none"> • Line pressure too low • Clutch No. 1 (C₁) worn • One-way clutch No.3 (F₃) not operating properly
N → R time lag is longer	<ul style="list-style-type: none"> • Line pressure too low • Clutch No. 3 (C₃) worn • Brake No. 4 (B₄) worn • One-way clutch No.1 (F₁) not operating properly

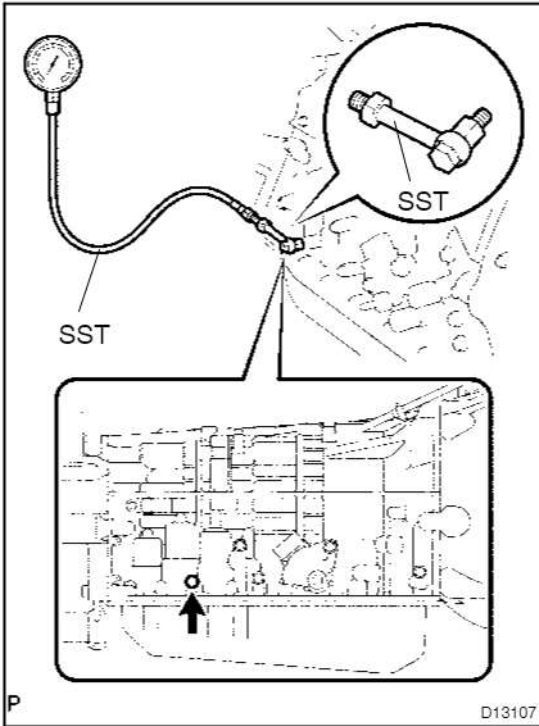

11. HYDRAULIC TEST

Measure the line pressure.

NOTICE:

- Do the test at normal operation fluid temperature 70 – 80°C (158 – 176°F).
 - The line pressure test should always be carried out in pairs. One technician should observe the conditions of wheels or wheel stoppers outside the vehicle while the other is doing the test.
 - Be careful to prevent SST's hose from interfering with the exhaust pipe.
 - (1) Warm up the ATF.
 - (2) Remove the test plug on the transmission case center right side and connect SST.
- SST 09992-00095 (09992-00231, 09992-00271)
- (3) Fully apply the parking brake and chock the 4 wheels.
 - (4) Start the engine and check idling speed.
 - (5) Keep your left foot pressing firmly on the brake pedal and shift into D range.
 - (6) Measure the line pressure when the engine is idling.
 - (7) Depress the accelerator pedal all the way down. Quickly read the highest line pressure when engine speed reaches stall speed.
 - (8) In the same manner, do the test in R range.

Specified line pressure:

Condition	D range kPa (kgf/cm ² , psi)	R range kPa (kgf/cm ² , psi)
Idling	362 – 420 (3.7 – 4.2, 53 – 59)	500 – 580 (5.1 – 5.9, 73 – 84)
Stall	1,360 – 1,460 (13.8 – 14.9, 196 – 212)	1,295 – 1,415 (13.2 – 14.4, 188 – 205)

Evaluation

Problem	Possible cause
If the measured value at all ranges are higher	<ul style="list-style-type: none"> • Shift solenoid valve SLT defective • Regulator valve defective
If the measured value at all ranges are lower	<ul style="list-style-type: none"> • Shift solenoid valve SLT defective • Regulator valve defective • Oil pump defective
If pressure is low in the D range only	<ul style="list-style-type: none"> • D range circuit fluid leakage • Clutch No. 1 (C₁) defective
If pressure is low in the R range only	<ul style="list-style-type: none"> • R range circuit fluid leakage • Clutch No. 3 (C₃) defective • Brake No. 4 (B₄) defective



12. MANUAL SHIFTING TEST

HINT:

By this test, it can be determined whether the trouble is within the electrical circuit or is a mechanical problem in the transmission.

- (a) Disconnect the solenoid wire.
- (b) Inspect the manual driving operation.

Check that the shift and gear ranges correspond with the table below.

While driving, shift through the L, 2, 3, 4 and D ranges. Check that the gear change corresponds to the shift range.

Shift range	Gear range
D	4th
4	4th
3	3rd
2	1st
L	1st
R	Reverse
P	Pawl Lock

HINT:

If the gear ranges of the L, 2, 3, 4 and D are difficult to distinguish, do the following road test.

If any abnormality is found in the above test, the problem is in the transmission itself.

- (c) Connect the solenoid wire.
- (d) Cancel out DTC.

13. RESET MEMORY

CAUTION:

Perform the **RESET MEMORY (AT initialization)** when replacing the automatic transmission assy, engine assy or the Engine and ECT ECU.

NOTICE:

Hand-held tester only

HINT:

The Engine and ECT ECU memorizes the condition that the ECT controls the automatic transmission assy and engine assy according to those characteristics. Therefore, when the automatic transmission assy, engine assy, or Engine and ECT ECU has been replaced, it is necessary to reset the memory so that the Engine and ECT ECU can memorize the new information.

Reset procedure is as follows.

- (a) Turn the ignition switch off.
- (b) Connect the hand-held tester to the DLC3.
- (c) Turn the ignition switch to the ON position and push the hand-held tester main switch on.
- (d) Select the item "/ DIAGNOSIS / OBD/MOBD".
- (e) Perform the reset memory procedure from the ENGINE menu.

CAUTION:

After performing the **RESET MEMORY**, be sure to perform the **ROAD TEST** described earlier.

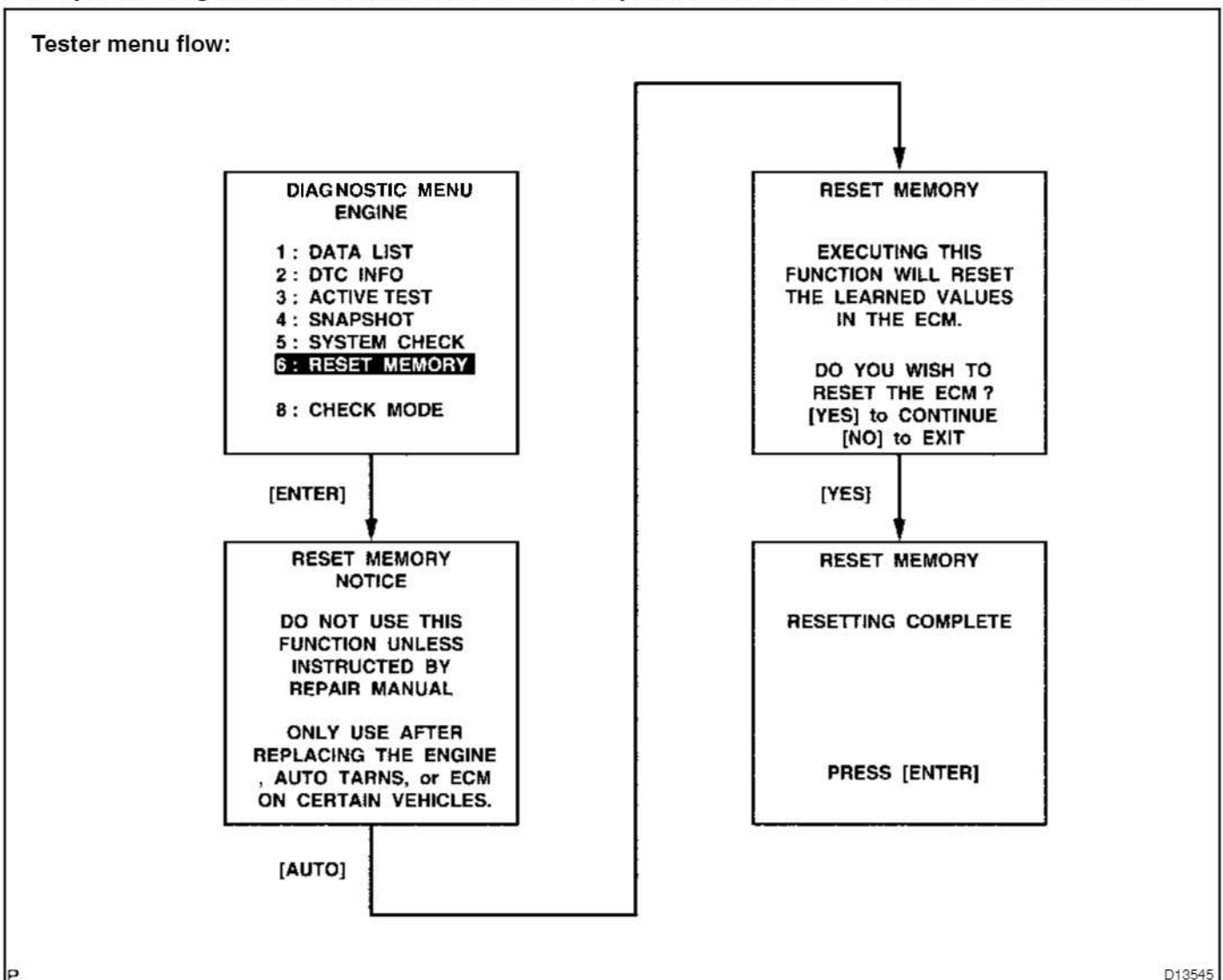

AUTOMATIC TRANSMISSION (A750F for 1HD-FTE)

HOW TO PROCEED WITH TROUBLESHOOTING

DI/V7-02

When using hand-held tester, troubleshoot in accordance with the procedure on the following pages.

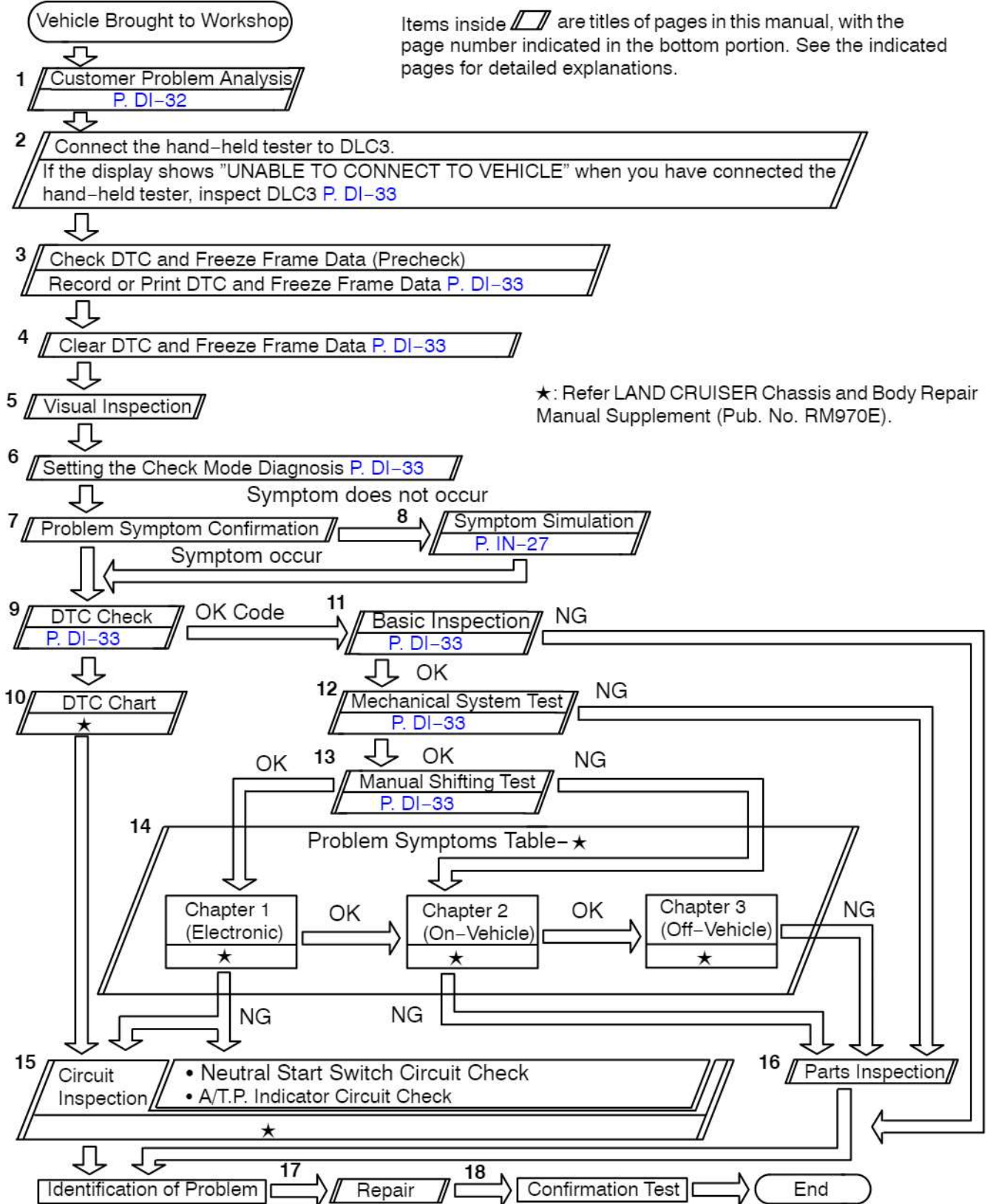

When using hand-held tester, troubleshoot in accordance with the procedure on the following pages.

Items inside  are titles of pages in this manual, with the page number indicated in the bottom portion. See the indicated pages for detailed explanations.

★: Refer LAND CRUISER Chassis and Body Repair Manual Supplement (Pub. No. RM970E).

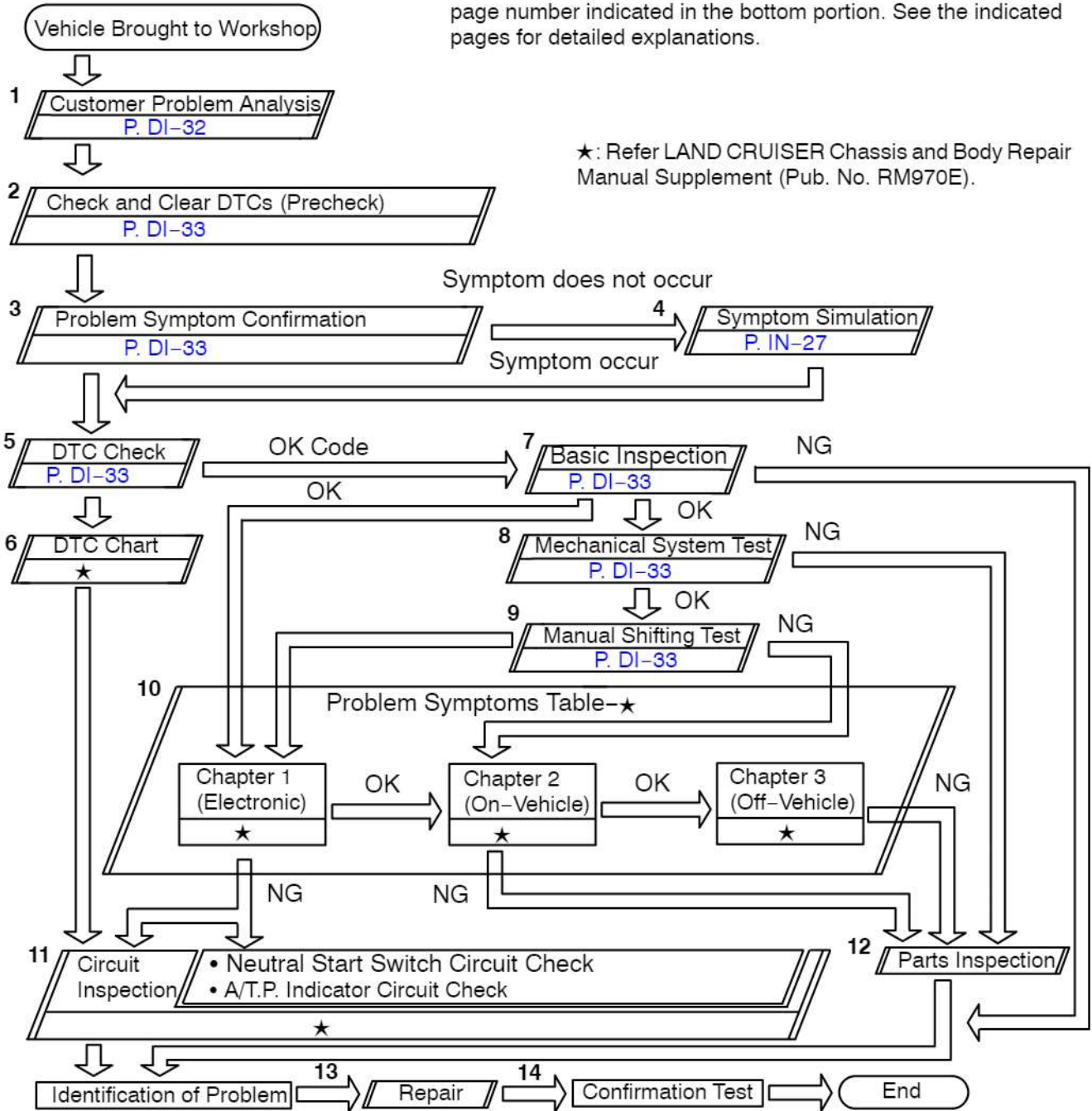

PRECAUTION

NOTICE:

Perform the **RESET MEMORY (AT initialization)** when replacing the automatic transmission assy, engine assy or the ECM (See page DI-33).

HINT:

Initialization can not be completed by only disconnecting the battery terminal.

CUSTOMER PROBLEM ANALYSIS CHECK

Automatic Transmission
System Check Sheet

Inspector's
Name :

Customer's Name		Registration No.	
		Registration Year	/ /
		Frame No.	
Date Vehicle Brought In	/ /	Odometer Reading	km mile

Date Problem Occurred	/ /
How Often Does Problem Occur?	<input type="checkbox"/> Continuous <input type="checkbox"/> Intermittent (times a day)

Symptoms	<input type="checkbox"/> Vehicle does not move (<input type="checkbox"/> Any range <input type="checkbox"/> particular range)
	<input type="checkbox"/> No up-shift (<input type="checkbox"/> 1st → 2nd <input type="checkbox"/> 2nd → 3rd <input type="checkbox"/> 3rd → 4th <input type="checkbox"/> 4th → 5th)
	<input type="checkbox"/> No down-shift (<input type="checkbox"/> 5th → 4th <input type="checkbox"/> 4th → 3rd <input type="checkbox"/> 3rd → 2nd <input type="checkbox"/> 2nd → 1st)
	<input type="checkbox"/> Lock-up malfunction
	<input type="checkbox"/> Shift point too high or too low
	<input type="checkbox"/> Harsh engagement (<input type="checkbox"/> N → D <input type="checkbox"/> Lock-up <input type="checkbox"/> Any drive range)
	<input type="checkbox"/> Slip or shudder
	<input type="checkbox"/> No kick-down
<input type="checkbox"/> Others ()	

Check Item	Malfunction Indicator Lamp	<input type="checkbox"/> Normal <input type="checkbox"/> Remains ON
------------	----------------------------	---

DTC Check	1st Time	<input type="checkbox"/> Normal code <input type="checkbox"/> Malfunction code (DTC)
	2nd Time	<input type="checkbox"/> Normal code <input type="checkbox"/> Malfunction code (DTC)

PRE-CHECK

1. DIAGNOSIS SYSTEM

(a) Description for M-OBD

- When troubleshoot Multiplex OBD (M-OBD) vehicles, the only difference from the usual troubleshooting procedure is that you connect the vehicle to the hand-held tester, and read off various data output from the vehicle's Engine and ECT ECU.
- The vehicle's on-board computer indicates the check engine light (CHK ENG) on the instrument panel when the computer detects a malfunction in the computer itself or in drive system components. In addition to an indication of the CHK ENG when a malfunction is detected, the applicable Diagnostic Trouble Codes (DTCs) are recorded in the Engine and ECT ECU memory (See Pub. No. RM970E, page DI-114).

If the malfunction code is not detected in 3 consecutive trips, CHK ENG (MIL) goes off automatically but the DTCs remain recorded in the Engine and ECT ECU memory.

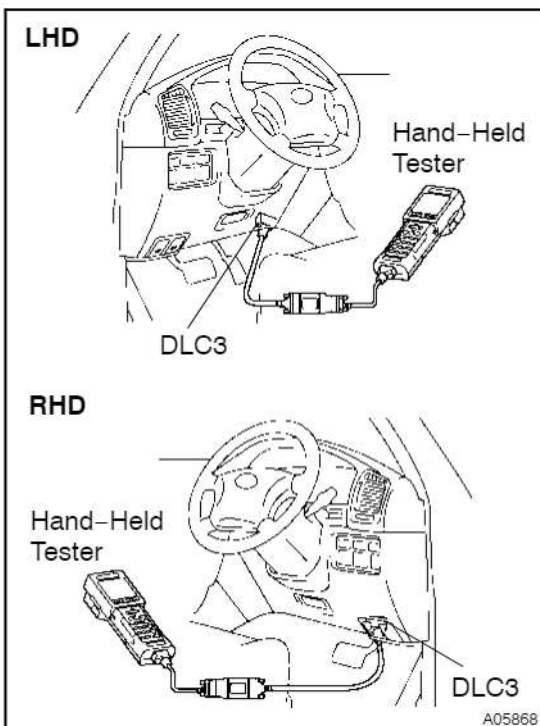

LAND CRUISER (W/G) SUP (RM1072E)

- To check the DTCs, connect the hand-held tester to Data Link Connector 3 (DLC3) on the vehicle, or read the number of blinks of the check engine warning light when TC and CG terminals on the DLC3 are connected. The hand-held tester also enables you to erase the DTCs and activate the several actuators and check frozen frame data and various forms of engine data. (For operating instructions, see the hand-held tester instruction book.)
- The diagnosis system operates in the normal mode during normal vehicle use. It also has a check (test) mode for technicians to simulate malfunction symptoms and troubleshoot. Most DTCs use 2 trip detection logic* to prevent erroneous detection, and ensure thorough malfunction detection. By switching the Engine and ECT ECU to the check (test) mode using hand-held tester when troubleshooting, the technician can cause the CHK ENG on the light up for a malfunction that is only detected once or momentarily (Hand-held tester only) (See step 2).

- * 2 trip detection logic
When a logic malfunction is first detected, the malfunction is temporarily stored in the Engine and ECT ECU memory. If the same malfunction is detected again during the second drive test, this second detection causes the CHK ENG to light up.
The 2 trip repeats the same mode for 2 times (However, the ignition switch must be turned OFF between the 1st trip and 2nd trip).

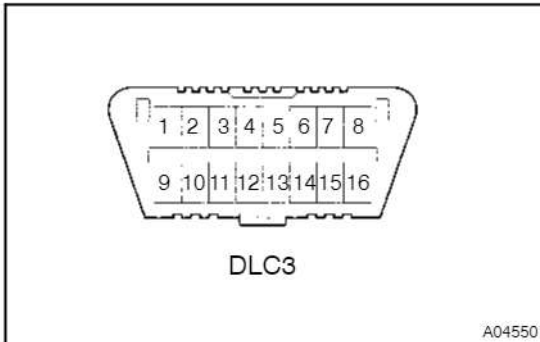

- (b) Check the DLC3.
The vehicle's Engine and ECT ECU uses the ISO 14230 (M-OBD) communication protocol. The terminal arrangement of DLC3 complies with ISO 15031-3 and matches the ISO 14230 format.

Terminal No.	Connection/Voltage or Resistance	Condition
7	Bus + Line/Pulse generation	During communication
4	Chassis Ground ↔ Body Ground/1 Ω or less	Always
5	Signal Ground – Body Ground/1 Ω or less	Always
16	Battery Positive ↔ Body Ground/9 – 14 V	Always

HINT:

If your display shows UNABLE TO CONNECT TO VEHICLE when you have connected the cable of the hand-held tester to the DLC3, turned the ignition switch ON and operated the scan tool, there is a problem on the vehicle side or tool side.

If communication is normal when the tool is connected to another vehicle, inspect the DLC3 on the original vehicle.

If communication is still not possible when the tool is connected to another vehicle, the problem is probably in the tool itself, so consult the Service Department listed in the tool's instruction manual.

2. INSPECT DIAGNOSIS (Normal Mode)

- (a) Check the DTC using hand-held tester.

NOTICE:

Hand-held tester only:

When the diagnosis system is switched from the normal mode to the check mode, it erases all DTCs and freed frame data recorded in the normal mode. So before switching modes, always check the DTCs and freed frame data, and note them down.

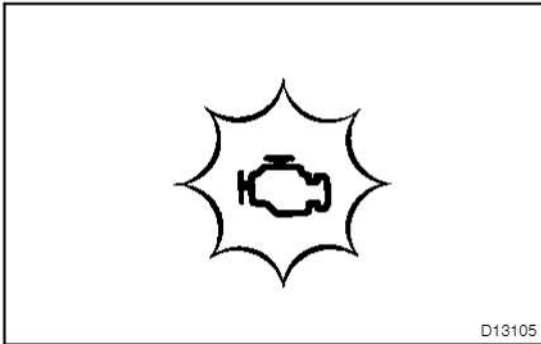

- (1) The CHK ENG (MIL) comes on when the ignition switch is turned ON and the engine is not running.
- (2) Prepare the hand-held tester.
- (3) Connect the hand-held tester to the DLC3.
- (4) Turn the ignition switch ON and push the hand-held tester main switch ON.
- (5) Use the hand-held tester to check the DTCs and freeze frame data, note them down (For operating instructions, see the hand-held tester instruction book.).
- (6) See Pub. No. RM970E, page DI-114 to confirm the details of the DTCs.

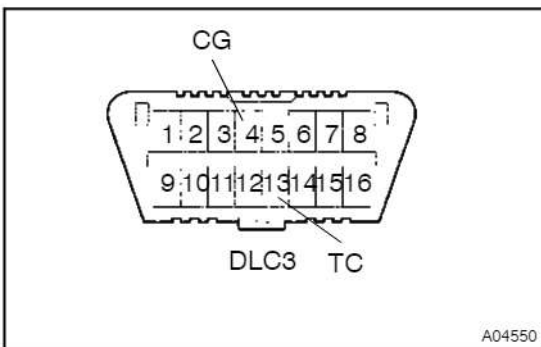

- (b) Check the DTC when not using hand-held tester (M-OBD).
 - (1) Turn the ignition switch ON, but do not start the engine.
 - (2) Using SST, connect terminals 13 (TC) and 4 (CG) of DLC3.
SST 09843-18040

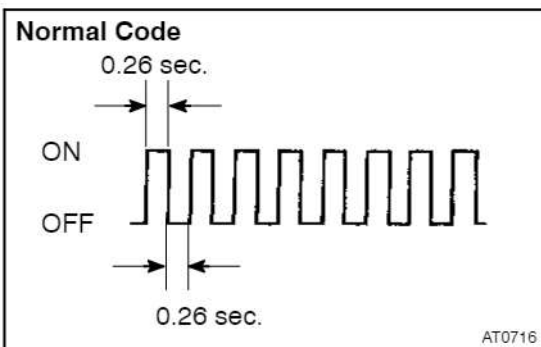

- (3) Read the DTC indicated by the number of times the MIL blinks.

HINT:
If the system is operating normally, the light will blink 2 times per second.

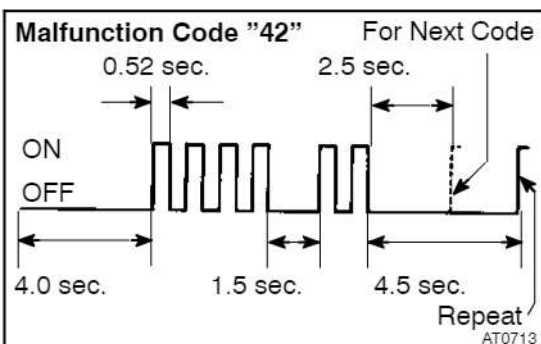

- (4) The malfunction code is indicated, as shown in the chart on the left (DTC "42" is shown as an example).

HINT:
When 2 or more malfunction codes are stored in memory, the lower-numbered code is displayed first.

3. INSPECT DIAGNOSIS (Check (Test) Mode)

HINT:

Hand-held tester only:

Compared to the normal mode, the check mode has an increased sensitivity to detect malfunctions.

Furthermore, the same diagnostic items which are detected in the normal mode can also be detected in the check (test) mode.

- (a) Check the DTC.
 - (1) Initial conditions
 - Battery voltage 11 V or more
 - Throttle valve fully closed
 - Transmission in P or N range
 - A/C switched OFF
 - (2) Turn the ignition switch OFF.
 - (3) Prepare the hand-held tester.

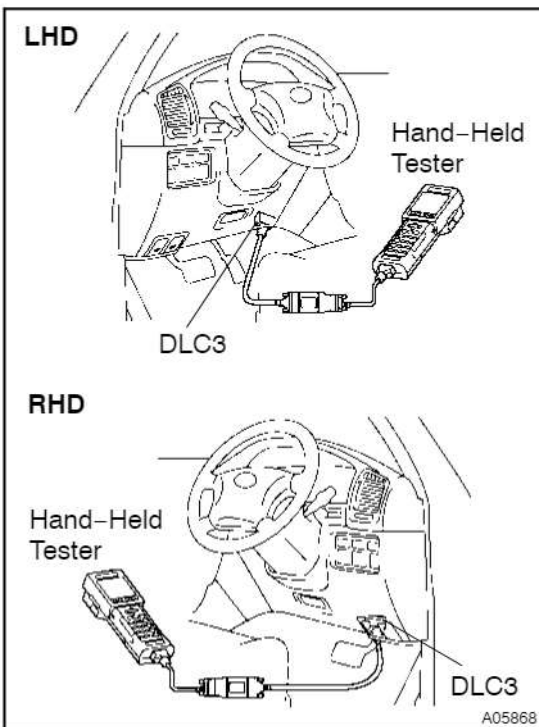

- (4) Connect the hand-held tester to the DLC3.
- (5) Turn the ignition switch ON and push the hand-held tester main switch ON.

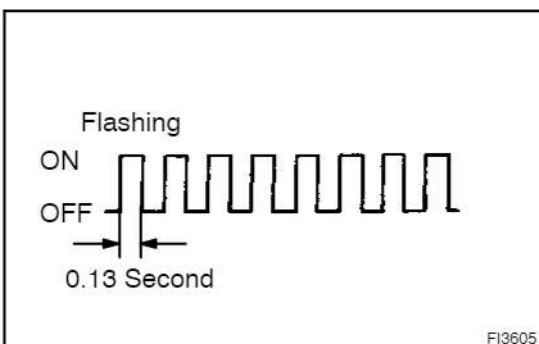

- (6) Switch the hand-held tester from the normal mode to the check (test) mode.
- (7) Check if the CHK ENG (MIL) blinks.

NOTICE:

If the hand-held tester switches the Engine and ECT ECU from the normal mode to the check mode or vice-versa, or if the ignition switch is turned from ON to ACC or OFF during the check mode, the DTCs and frozen frame data will be erased.

- (8) Start the engine (MIL goes out after the engine starts).
- (9) Simulate the conditions of the malfunction described by the customer.

NOTICE:

Leave the ignition switch ON until you have checked the DTCs, etc.

- (10) After simulating the malfunction conditions, use the hand-held tester diagnosis selector to check the DTCs and freeze frame data, etc.

HINT:

Take care not to turn the ignition switch OFF. Turning the ignition switch OFF switches the diagnosis system from the check (test) mode to the normal mode. so all DTCs, etc. are erased.

- (11) After checking the DTC, inspect the applicable circuit.
- (b) Clear the DTC.
The DTCs and freeze frame data will be erased by either actions.
- (1) Operating the hand-held tester to erase the codes. (See the hand-held tester's instruction book for operating instructions.)
 - (2) Disconnecting the battery terminals or (EFI OR ECD No.1 fuse) and (EFI OR ECD No.2 fuse) fuse more than 60 second.

4. PROBLEM SYMPTOM CONFIRMATION

Taking into consideration the results of the customer problem analysis, try to reproduce the symptoms of the trouble. If the problem is that the transmission does not up-shift, down-shift, or the shift point is too high or too low, conduct the following road test to confirm the automatic shift schedule and simulate the problem symptoms.

5. ROAD TEST**NOTICE:**

Perform the test at normal operating ATF temperature 50 – 80°C (122 – 176°F).

- (a) D range test (NORM and PWR pattern):

Shift into the D range and fully depress the accelerator pedal and check the following points.

- (1) Check up-shift operation.
Check that 1 → 2, 2 → 3, 3 → 4 and 4 → 5th up-shifts take place, and that the shift points conform to the automatic shift schedule (See Pub. No. RM970E, page SS-4).

HINT:

When the 2nd start switch is on, there is no 1→2 up-shift and 2→1 down-shift.

- (2) Check for shift shock and slip.
Check for shock and slip at the 1 → 2, 2 → 3, 3 → 4 and 4 → 5th up-shifts.
- (3) Check for abnormal noises and vibration.
Drive in the D range lock-up or 5th gear and check for abnormal noises and vibration.

HINT:

The check for the cause of abnormal noises and vibration must be done very thoroughly as it could also be due to loss of balance in the differential, torque converter clutch, etc.

- (4) Check kick-down operation.
While running in the D range, 2nd, 3rd, 4th and 5th gears, check that the possible kick-down vehicle speed limits for 2 → 1, 3 → 2, 4 → 3 and 5th → 4 kick-downs conform to those indicated on the automatic shift schedule (See Pub. No. RM970E, page SS-4).
- (5) Check abnormal shock and slip at kick-down.
- (6) Check the lock-up mechanism.
 - Drive in D range 5th gear, at a steady speed (lock-up ON) of about 70 km/h (43 mph).
 - Lightly depress the accelerator pedal and check that the engine speed does not change abruptly.

If there is a big jump in engine speed, there is no lock-up.

(b) 4 range test:

Shift into the 4 range and fully depress the accelerator pedal and check the following points.

- (1) Check up-shift operation.
Check that the 1 → 2, 2 → 3 and 3 → 4 up-shift takes place and that the shift point conforms to the automatic shift schedule (See Pub. No. RM970E, page SS-4).

HINT:

- There is no 5th up-shift in the 4 range.
 - 4th Gear Lock-up Prohibition Control (1. Brake pedal is depressed. 2. Coolant temp. is 60°C (140°F) or less.)
- (2) Check engine braking.
While driving in the 4 range and 4th gear, release the accelerator pedal and check the engine braking effect.
 - (3) Check for abnormal noises during acceleration and deceleration, and for shock at up-shift and down-shift.
 - (4) Check the lock-up mechanism.
 - Drive in 4 range 4th gear, at a steady speed (lock-up ON) of about 61 km/h (38 mph).
 - Lightly depress the accelerator pedal and check that the engine speed does not change abruptly.

If there is a big jump in engine speed, there is no lock-up.

(c) 3 range test:

Shift into the 3 range and fully depress the accelerator pedal and check the following points.

- (1) Check up-shift operation.
Check that the 1 → 2 and 2 → 3 up-shift takes place and that the shift point conforms to the automatic shift schedule (See Pub. No. RM970E, page SS-4).
- (2) Check engine braking.
While running in the 3 range and 3rd gear, release the accelerator pedal and check the engine braking effect.
- (3) Check for abnormal noises during acceleration and deceleration, and for shock at up-shift and down-shift.

(d) 2 range test:

Shift into the 2 range and fully depress the accelerator pedal and check the following points.

- (1) Check up-shift operation.
Check that the 1 → 2 up-shift takes place and that the shift point conforms to the automatic shift schedule (See Pub. No. RM970E, page SS-4).

HINT:

When the 2nd start switch is ON, there is no 1 → 2 up-shift and 2 → 1 down-shift.

- (2) Check engine braking.
While running in the 2 range and 2nd gear, release the accelerator pedal and check the engine braking effect.
- (3) Check for abnormal noises during acceleration and deceleration, and for shock at up-shift and down-shift.
- (e) L range test:
Shift into the L range and fully depress the accelerator pedal and check the following points.
- (1) Check no up-shift.
While running in the L range, check that there is no up-shift to 2nd gear.
- (2) Check engine braking.
While running in the L range, release the accelerator pedal and check the engine braking effect.
- (3) Check for abnormal noises during acceleration and deceleration.
- (f) R range test:
Shift into the R range and fully depress the accelerator pedal and check for slipping.

CAUTION:

Before conducting this test ensure that the test area is free from people and obstruction.

- (g) P range test:
Stop the vehicle on a grade (more than 5°) and after shifting into the P range, release the parking brake. Then, check that the parking lock pawl holds the vehicle in place.

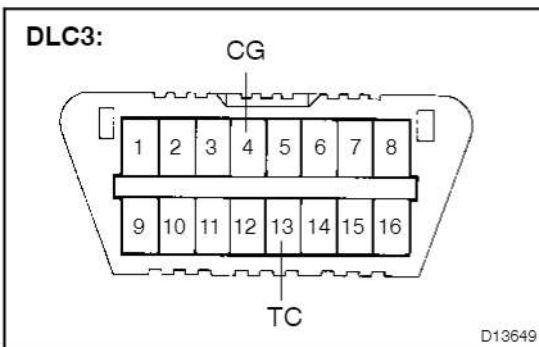
**6. BASIC INSPECTION**

- (a) Check the fluid level.
- (1) Using an SST, short-circuit between terminals TC and CG of the DLC3.
SST 09843-18040
- (2) Start the engine and run at idle.
- A/C switch must be turned off.
 - On the model with the active height control suspension & adaptive variable suspension, turn the height control switch off.
- (3) Slowly move the shift lever through all the ranges from P to L, and move it back to the P range.
- (4) Move the shift lever from the N to the D range, or from D to N, within 1.5 seconds. Perform the above procedure for 6 seconds or more. This will activate the oil temperature detection mode.

Standard: The A/T OIL TEMP warning light comes on for 2 seconds and then goes off.

- (5) Return the shift lever to the P range and disconnect terminal TC and CG.
- (6) Idle the engine to raise the oil temperature.
- (7) Lift up the vehicle right after the meter indicator light "ATF temperature warning light" comes on.
- The A/T OIL TEMP warning light indicates the ATF temperature according to the following table.

ATF Temp.	Less than optimized temperature	Optimized temperature	More than optimized temperature
A/T OIL TEMP warning light	OFF	ON	Blinking

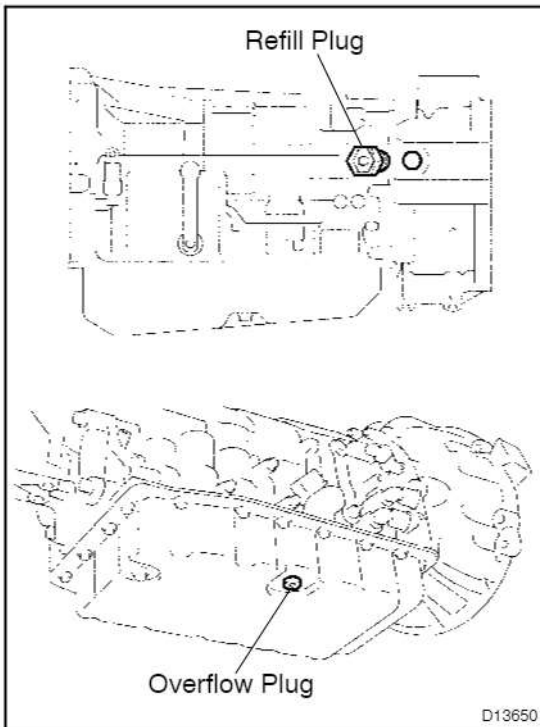

- (8) Remove the overflow plug and check the fluid level.

Standard:

When ATF overflows *	ATF level is higher than the specification (Go to step (11))
When ATF does not overflow	ATF level is equal to or lower than specification (Go to step (9))

*: Since the overflow capacity is 3 cc, check if the drained ATF is 3 cc or more.

- (9) Remove the refill plug.

Fluid type: AUTO FLUID WS

- (10) Fill ATF to the refill plug until it flows out from the overflow plug.

- (11) When the draining ATF becomes a trickle, install the overflow plug through a new gasket.

- (12) Install the refill plug (only if the refill plug has been removed).

- (13) Lower the vehicle down.

- (14) Turn the ignition switch off to stop the engine.

- (b) Check the fluid condition.

If the fluid smells burnt or is black, replace it (see step 7.).

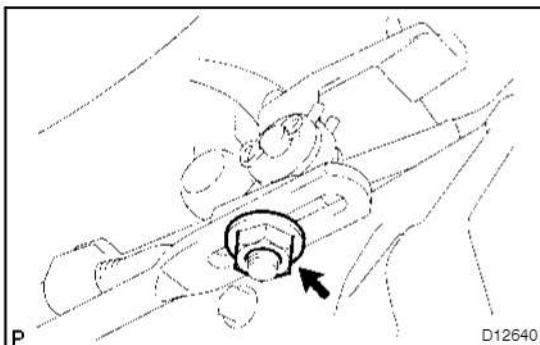

- (c) Inspect and adjust the shift lever range.

When shifting the shift lever from the N range to other ranges, check that the lever can be shifted smoothly and accurately to each range and that the range indicator is not aligned with the correct range.

If the indicator is not aligned with the correct range, carry out the following adjustment procedures.

- (1) Loosen the nut on the shift lever.

- (2) Push the control shaft fully rearward.

- (3) Return the control shaft lever 2 notches to N range.

- (4) Set the shift lever to N range.

- (5) While holding the shift lever lightly toward the R range side, tighten the shift lever nut.

Torque: 13 N·m (130 kgf·cm, 9 ft·lbf)

- (6) Start the engine and make sure that the vehicle moves forward when shifting the lever from the N to D range and reverses when shifting it to the R range.

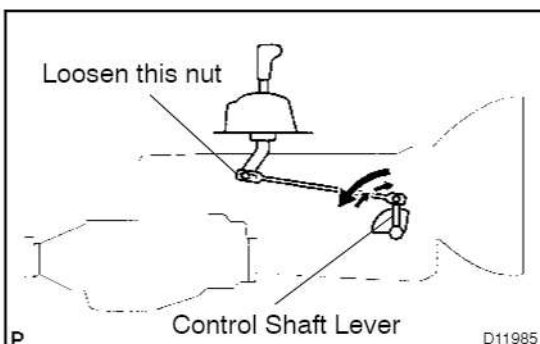

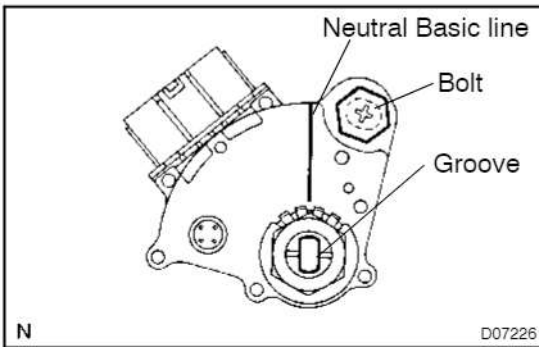

- (d) Inspect and adjust the neutral start switch.
- Check that the engine can be started with the shift lever only in the N or P range, but not in other ranges.

If it is not as stated above, carry out the following adjustment procedures.

- Loosen the neutral start switch bolt and set the shift lever to the N range.
- Align the groove with neutral basic line.
- Hold in range and tighten the bolt.

Torque: 13 N·m (130 kgf·cm, 9 ft·lbf)

- For continuity inspection of the neutral start switch, (See Pub. No. RM970E, page DI-156).

- (e) Check the idle speed.

Idle speed (In N range and air conditioner OFF):

700 ± 50 rpm

7. ADD AUTOMATIC TRANSMISSION FLUID

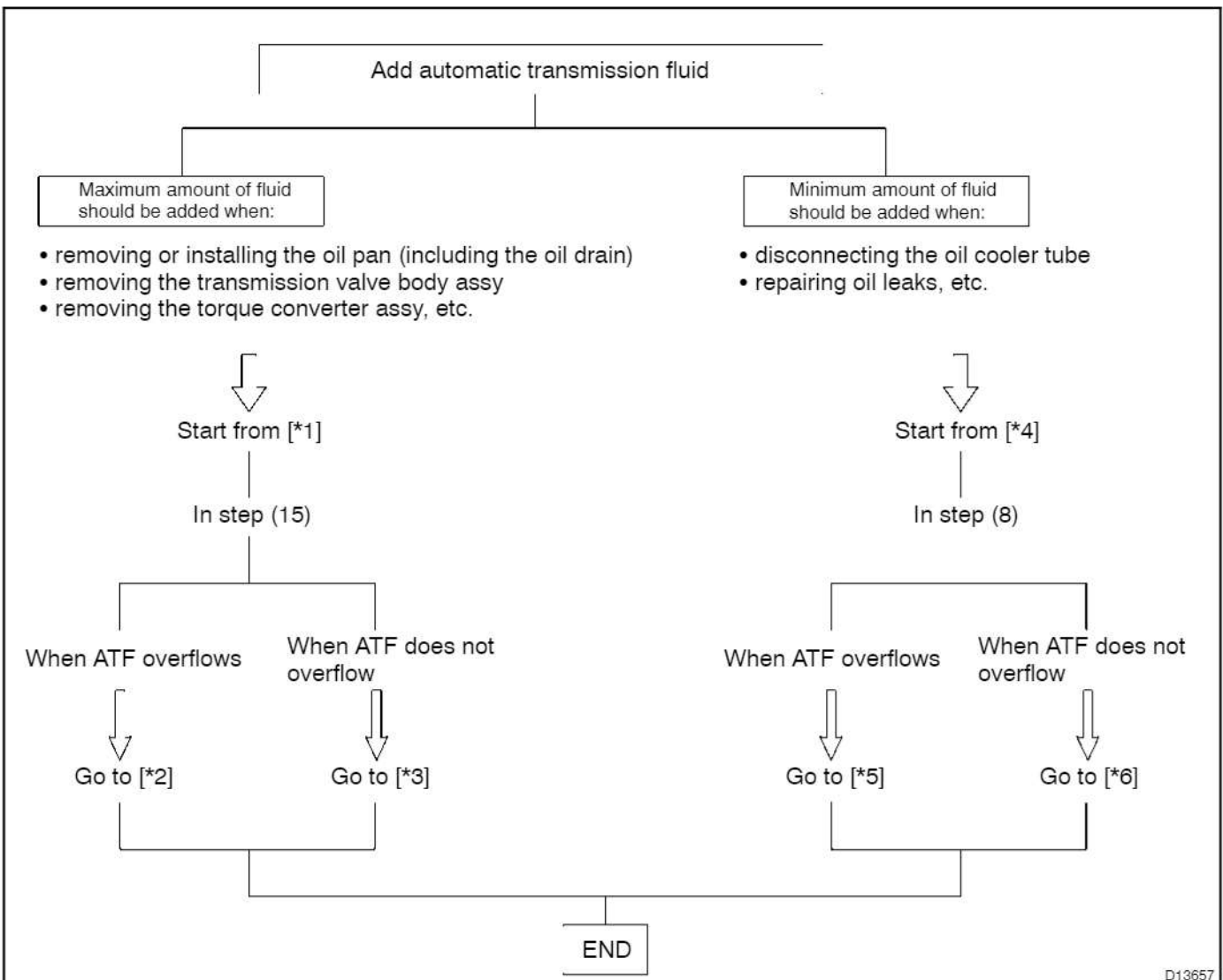

- (a) When adding a maximum amount of fluid: [*1]
 (1) Lift the vehicle while keeping it level.

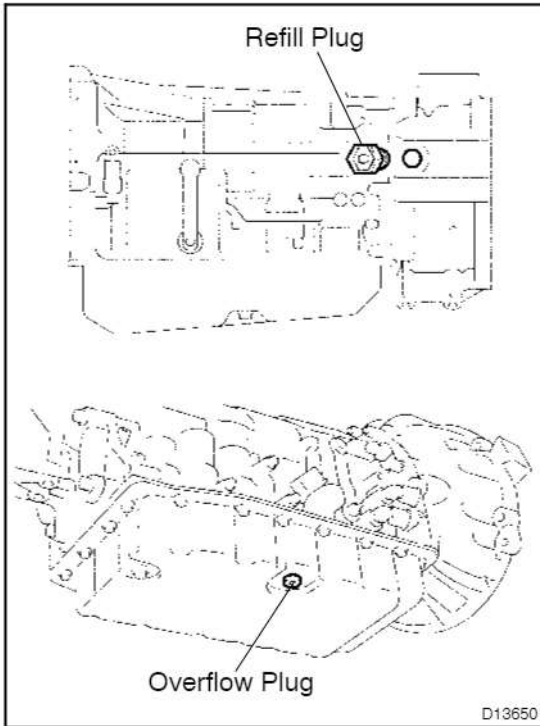

- (2) Remove the refill plug and overflow plug.

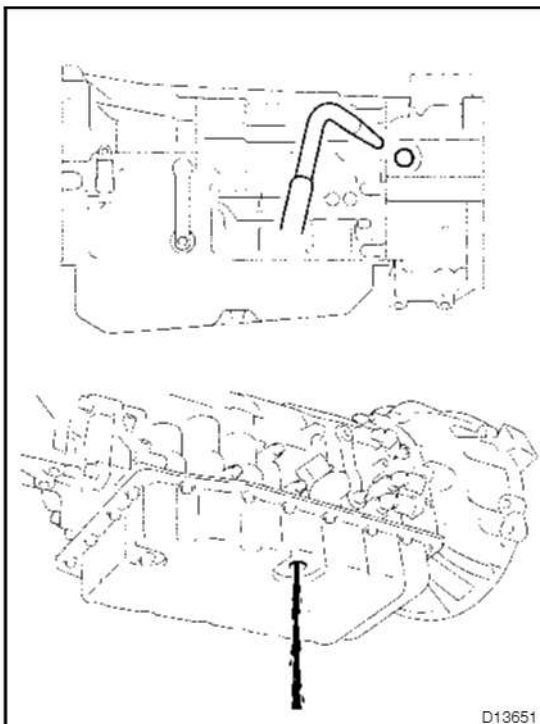

- (3) Add ATF to the refill hole until it drains out from the overflow hole.

NOTICE:
Be sure to add ATF WS.

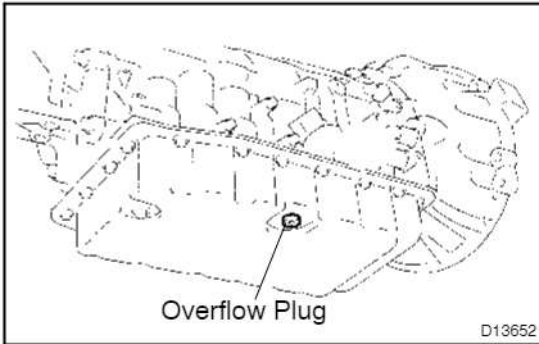

- (4) Temporarily install the gasket and overflow plug.
Torque: 20 N·m (204 kgf·cm, 15 ft·lbf)
- (5) Add proper amount of ATF to the refill hole.

NOTICE:

Refill amount is different depending on the related procedures.

Related procedures	Refill amount
Removal and installation of oil pan	1.7 liters (1.8 us qts, 1.5 Imp.qts)
Removal of transmission valve body assy	4.3 liters (4.5 us qts, 3.8 Imp.qts)
Removal of torque converter assy	5.4 liters (5.7 us qts, 4.8 Imp.qts)

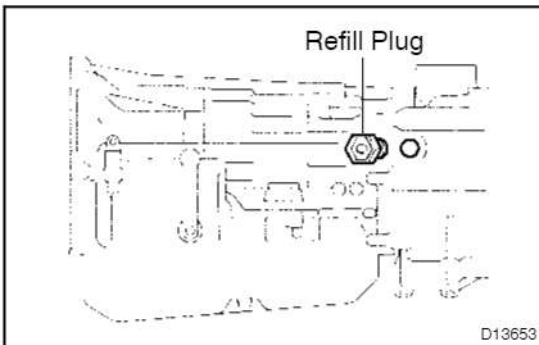

- (6) Temporarily install the O-ring and refill plug.
Torque: 39 N·m (400 kgf·cm, 29 ft·lbf)
- (7) Lower down the vehicle.

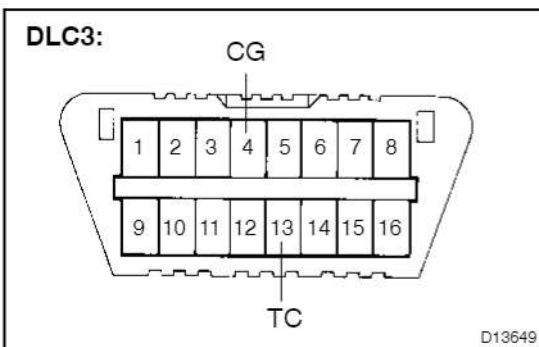

- (8) Using an SST, short-circuit between terminals TC and CG of the DLC3.
SST 09843-18040
- (9) Start the engine and run at idle.

NOTICE:

A/C switch must be turned off.

- (10) Slowly move the shift lever from the P to the 2-L range.
Return the shift lever to the P range.



- (11) Switch to the fluid temperature detection mode.
 - Move the shift lever from the N to the 4D range, or from 4D to N, within 1.5 seconds.
 - Perform the above procedure for 6 seconds or more.

Standard: Meter indicator light "ATF temperature warning light" comes on for 2 seconds and then goes off.

- (12) Disconnect terminals TC and CG after confirming the above condition.

(13) Idle the engine to raise fluid temperature.

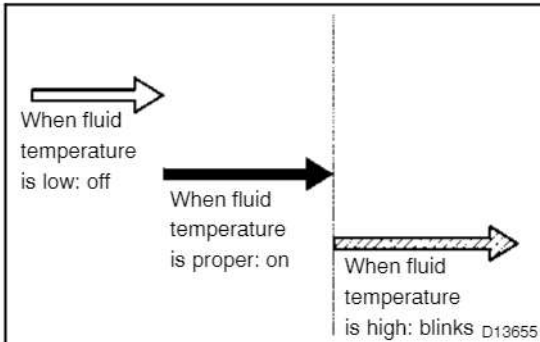

(14) Lift up the vehicle right after the meter indicator light "ATF temperature warning light" comes on.

NOTICE:

- **Add fluid only when the meter indicator light is on.**
- **Perform the procedure while the engine is idling.**

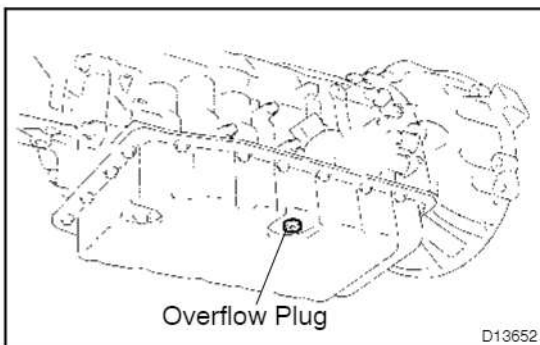

(15) Remove the overflow plug. If ATF overflows, proceed to [*2].

If ATF does not overflow, proceed to [*3].

HINT:

"Overflow" indicates the condition that ATF drains out from the overflow tube.

NOTICE:

Capacity of the overflow tube is approximately 3 cc.

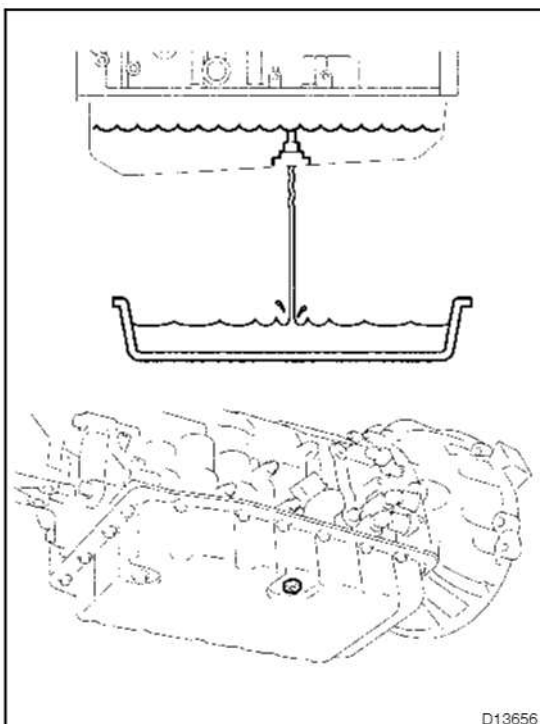

(b) When fluid overflows: [*2]

(1) Install the overflow plug through a new gasket when the draining ATF becomes a trickle.

Torque: 20 N·m (204 kgf·cm, 15 ft·lbf)

(2) Install the refill plug through a new O-ring.

Torque: 39 N·m (400 kgf·cm, 29 ft·lbf)

(3) Lower down the vehicle.

(4) Turn the ignition switch off.

(5) Check the fluid leaks.

Check for leaks in the transmission.

If there are leaks, it is necessary to repair or replace O-rings, FIGs, oil seals, plugs or other parts.

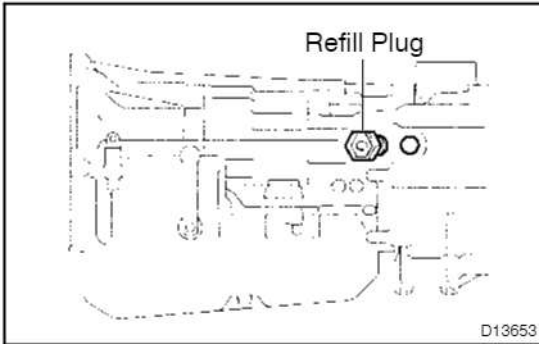

(c) When fluid does not overflow: [*3]

(1) Remove the refill plug.

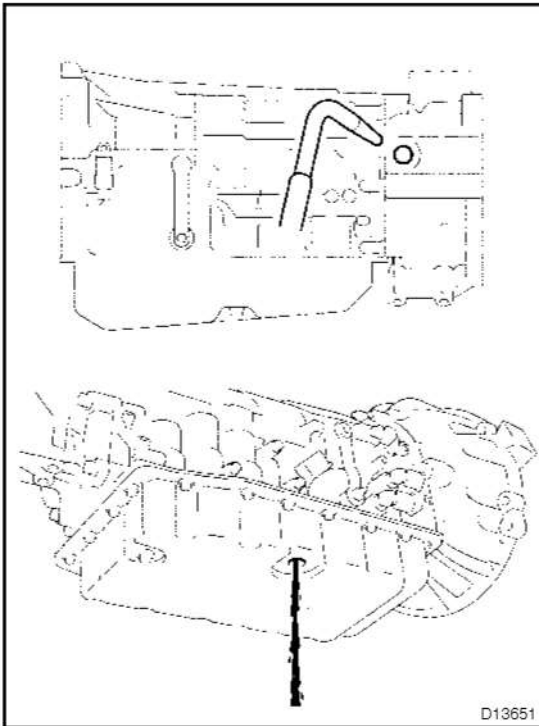

(2) Add ATF to the refill hole until it drains out from the overflow hole.

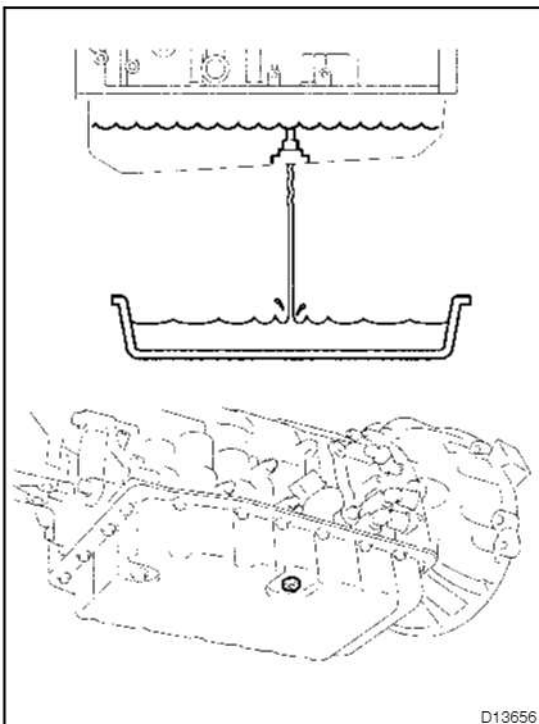

(3) Install the overflow plug through a new gasket when the draining ATF becomes a trickle.

Torque: 20 N·m (204 kgf·cm, 15 ft·lbf)

(4) Install the refill plug through a new O-ring.

Torque: 39 N·m (400 kgf·cm, 29 ft·lbf)

(5) Lower down the vehicle.

(6) Turn the ignition switch off.

(7) Check the fluid leaks.

Check for leaks in the transmission.

If there are leaks, it is necessary to repair or replace O-rings, FIGs, oil seals, plugs or other parts.

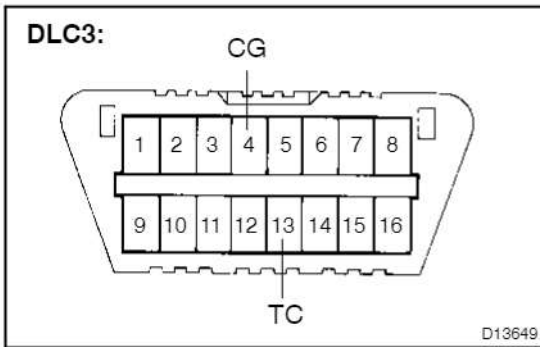

- (d) When adding a minimum amount of fluid: [*4]
- (1) Using an SST, short-circuit between terminals TC and CG of the DLC3.
- SST 09843-18040
- (2) Start the engine and run at idle.

NOTICE:**A/C switch must be turned off.**

- (3) Slowly move the shift lever from the P to the 2-L range. Return the shift lever to the P range.
- (4) Switch to the fluid temperature detection mode.
 - Move the shift lever from the N to the 4D range, or from 4D to N, within 1.5 seconds.
 - Perform the above procedure for 6 seconds or more.

Standard: Meter indicator light "ATF temperature warning light" comes on for 2 seconds and then goes off.

- (5) Disconnect terminals TC and CG after confirming the above condition.
- (6) Idle the engine to raise fluid temperature.

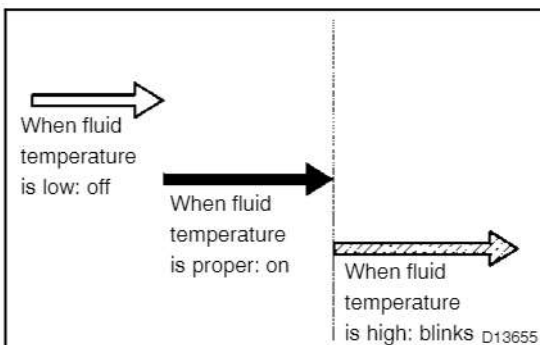

- (7) Lift up the vehicle right after the meter indicator light "ATF temperature warning light" comes on.

NOTICE:

- **Add fluid only when the meter indicator light is on.**
- **Perform the procedure while the engine is idling.**

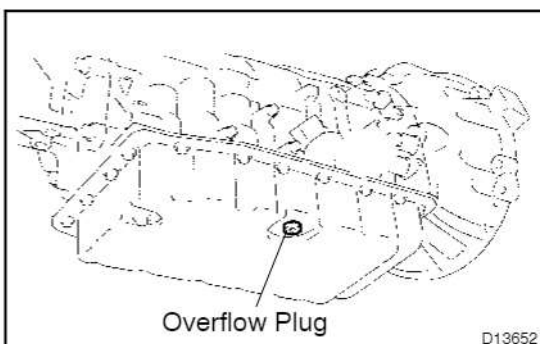

- (8) Remove the overflow plug. If ATF overflows, proceed to [*5]. If ATF does not overflow, proceed to [*6].

HINT:

"Overflow" indicates the condition that ATF drains out from the overflow tube.

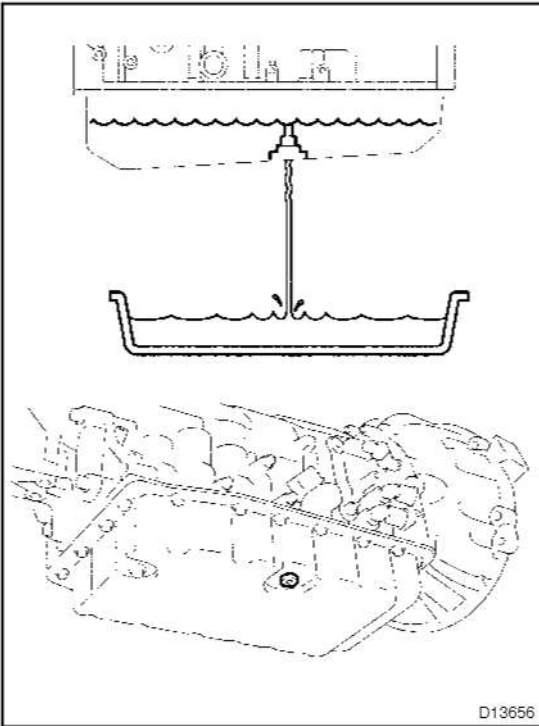

- (e) When fluid overflows: [*5]
 (1) Install the overflow plug through a new gasket when the draining ATF becomes a trickle.

Torque: 20 N·m (204 kgf·cm, 15 ft·lbf)

- (2) Install the refill plug through a new O-ring.

Torque: 39 N·m (400 kgf·cm, 29 ft·lbf)

- (3) Lower down the vehicle.
 (4) Turn the ignition switch off.
 (5) Check the fluid leaks.

Check for leaks in the transmission.

If there are leaks, it is necessary to repair or replace O-rings, FIPGs, oil seals, plugs or other parts.

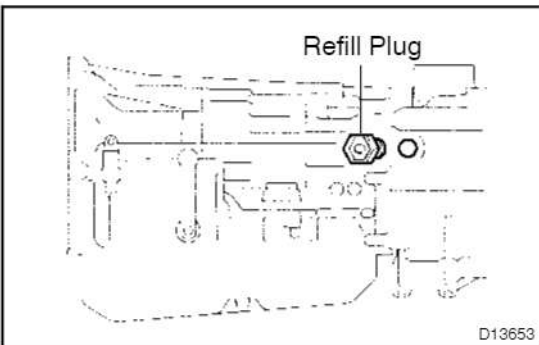

- (f) When fluid does not overflow: [*6]

- (1) Remove the refill plug.

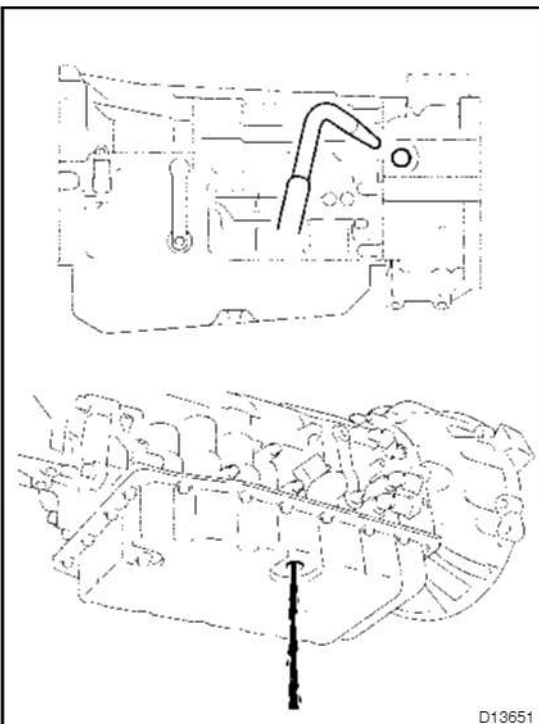

- (2) Add ATF to the refill hole until it drains out from the overflow hole.

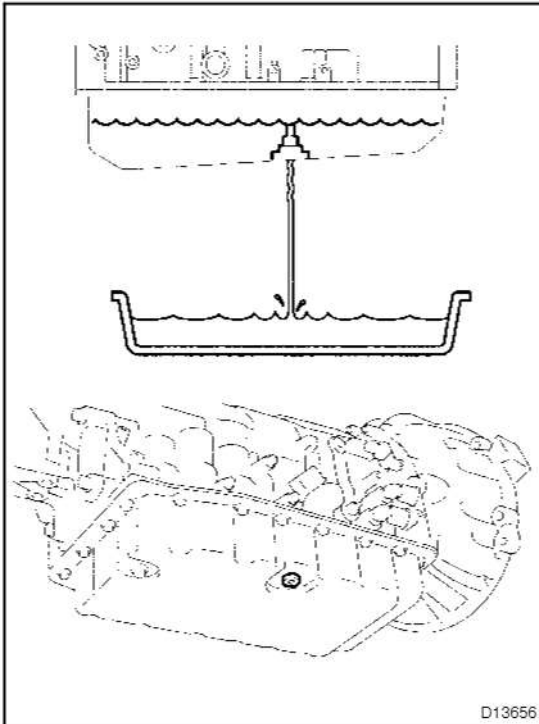

- (3) Install the overflow plug through a new gasket when the draining ATF becomes a trickle.

Torque: 20 N·m (204 kgf·cm, 15 ft·lbf)

- (4) Install the refill plug through a new O-ring.

Torque: 39 N·m (400 kgf·cm, 29 ft·lbf)

- (5) Lower down the vehicle.
- (6) Turn the ignition switch off.
- (7) Check the fluid leaks.

Check for leaks in the transmission.

If there are leaks, it is necessary to repair or replace O-rings, FIPGs, oil seals, plugs or other parts.

8. MECHANICAL SYSTEM TESTS

- (a) Measure the stall speed.

The object of this test is to check the overall performance of the transmission and engine by measuring the stall speeds in the D and R ranges.

NOTICE:

- Do the test at normal operating fluid temperature 70 – 80 °C (158 – 176 °F).
- Do not continuously run this test longer than 5 seconds.
- To ensure safety, conduct this test in a wide, clear level area which provides good traction.
- The stall test should always be carried out in pairs. One technician should observe the conditions of wheels or wheel stoppers outside the vehicle while the other is doing the test.

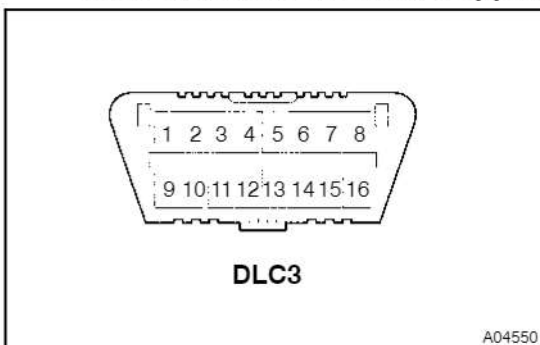

- (1) Chock the 4 wheels.
- (2) Connect a hand-held tester to DLC3 or tachometer to terminal TAC (9) of DLC3 with SST.

SST 09843-18030

- (3) Fully apply the parking brake.
- (4) Keep your left foot pressing firmly on the brake pedal.
- (5) Start the engine.
- (6) Shift into the D range. Press all the way down on the accelerator pedal with your right foot. Quickly read the stall speed at this time.

Stall speed: 2,400 ± 150 rpm

- (7) Do the same test in R range.

Stall speed: 2,400 ± 150 rpm

Evaluation:

Problem	Possible cause
(a) Stall speed low in D and R ranges	<ul style="list-style-type: none"> • Engine output may be insufficient • Stator one-way clutch is not operating properly HINT: If the value is larger or smaller than the specified value by 600 rpm or more, the torque converter could be faulty.
(b) Stall speed high in D range	<ul style="list-style-type: none"> • Line pressure too low • Clutch No. 1 (C₁) slipping • One-way clutch No.3 (F₃) not operating properly
(c) Stall speed high in R range	<ul style="list-style-type: none"> • Line pressure too low • Brake No. 4 (B₄) slipping • Clutch No. 3 (C₃) slipping • One-way clutch No.1 (F₁) not operating properly
(d) Stall speed high in D and R ranges	<ul style="list-style-type: none"> • Line pressure too low • Improper fluid level

(b) Measure the time lag.

When the shift lever is shifted while the engine is idling, there will be a certain time lapse or lag before the shock can be felt. This is used for checking the condition of the clutch and brake.

NOTICE:

- **Do the test at normal operating fluid temperature 70 – 80 °C (158 – 176 °F).**
- **Be sure to allow 1 minute interval between tests.**
- **Take 3 measurements and take the average value.**

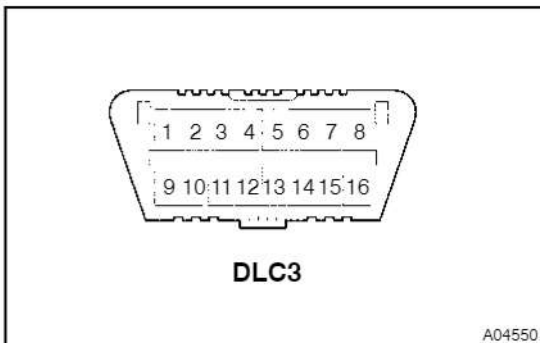

(1) Fully apply the parking brake.

(2) Connect a hand-held tester to DLC3 or tachometer to terminal TAC (9) of DLC3 with SST.

SST 09843-18030

(3) Start the engine and check idle speed.

Idle speed (In N range and air conditioner OFF): 700 ± 50 rpm.

(4) Shift the shift lever from N to D range. Using a stop watch, measure the time from when the lever is shifted until the shock is felt.

Time lag:

N → D Less than 1.2 seconds

(5) In the same manner, measure the time lag for N → R.

Time lag:

N → R Less than 1.5 seconds

Evaluation (If N → D time or N → R time lag is longer than the specified):

Problem	Possible cause
N → D time lag is longer	<ul style="list-style-type: none"> • Line pressure too low • Clutch No. 1 (C₁) worn • One-way clutch No.3 (F₃) not operating properly
N → R time lag is longer	<ul style="list-style-type: none"> • Line pressure too low • Clutch No. 3 (C₃) worn • Brake No. 4 (B₄) worn • One-way clutch No.1 (F₁) not operating properly

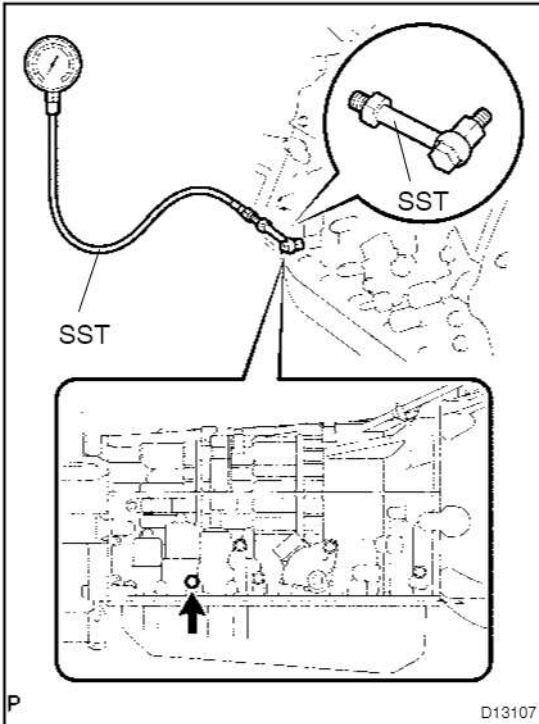

9. HYDRAULIC TEST

Measure the line pressure.

NOTICE:

- Do the test at normal operation fluid temperature 70 – 80 °C (158 – 176 °F).
 - The line pressure test should always be carried out in pairs. One technician should observe the conditions of wheels or wheel stoppers outside the vehicle while the other is doing the test.
 - Be careful to prevent SST's hose from interfering with the exhaust pipe.
 - (1) Warm up the ATF.
 - (2) Remove the test plug on the transmission case center right side and connect SST.
- SST 09992-00095 (09992-00231, 09992-00271)
- (3) Fully apply the parking brake and chock the 4 wheels.
 - (4) Start the engine and check idling speed.
 - (5) Keep your left foot pressing firmly on the brake pedal and shift into D range.
 - (6) Measure the line pressure when the engine is idling.
 - (7) Depress the accelerator pedal all the way down. Quickly read the highest line pressure when engine speed reaches stall speed.
 - (8) In the same manner, do the test in R range.

Specified line pressure:

Condition	D range kPa (kgf/cm ² , psi)	R range kPa (kgf/cm ² , psi)
Idling	362 – 420 (3.7 – 4.2, 53 – 59)	500 – 580 (5.1 – 5.9, 73 – 84)
Stall	1,360 – 1,460 (13.8 – 14.9, 196 – 212)	1,295 – 1,415 (13.2 – 14.4, 188 – 205)

Evaluation

Problem	Possible cause
If the measured value at all ranges are higher	<ul style="list-style-type: none"> • Shift solenoid valve SLT defective • Regulator valve defective
If the measured value at all ranges are lower	<ul style="list-style-type: none"> • Shift solenoid valve SLT defective • Regulator valve defective • Oil pump defective
If pressure is low in the D range only	<ul style="list-style-type: none"> • D range circuit fluid leakage • Clutch No. 1 (C₁) defective
If pressure is low in the R range only	<ul style="list-style-type: none"> • R range circuit fluid leakage • Clutch No. 3 (C₃) defective • Brake No. 4 (B₄) defective



10. MANUAL SHIFTING TEST

HINT:

By this test, it can be determined whether the trouble is within the electrical circuit or is a mechanical problem in the transmission.

- (a) Disconnect the solenoid wire.
- (b) Inspect the manual driving operation.

Check that the shift and gear ranges correspond with the table below.

While driving, shift through the L, 2, 3, 4 and D ranges. Check that the gear change corresponds to the shift range.

Shift range	Gear range
D	4th
4	4th
3	3rd
2	1st
L	1st
R	Reverse
P	Pawl Lock

HINT:

If the gear ranges of the L, 2, 3, 4 and D are difficult to distinguish, do the following road test.

If any abnormality is found in the above test, the problem is in the transmission itself.

- (c) Connect the solenoid wire.
- (d) Cancel out DTC.

11. RESET MEMORY

CAUTION:

Perform the **RESET MEMORY (AT initialization)** when replacing the automatic transmission assy, engine assy or the Engine and ECT ECU.

NOTICE:

Hand-held tester only

HINT:

The Engine and ECT ECU memorizes the condition that the ECT controls the automatic transmission assy and engine assy according to those characteristics. Therefore, when the automatic transmission assy, engine assy, or Engine and ECT ECU has been replaced, it is necessary to reset the memory so that the Engine and ECT ECU can memorize the new information.

Reset procedure is as follows.

- Turn the ignition switch off.
- Connect the hand-held tester to the DLC3.
- Turn the ignition switch to the ON position and push the hand-held tester main switch on.
- Select the item "/ DIAGNOSIS / OBD/MOBD".
- Perform the reset memory procedure from the ENGINE menu.

CAUTION:

After performing the **RESET MEMORY**, be sure to perform the **ROAD TEST** described earlier.

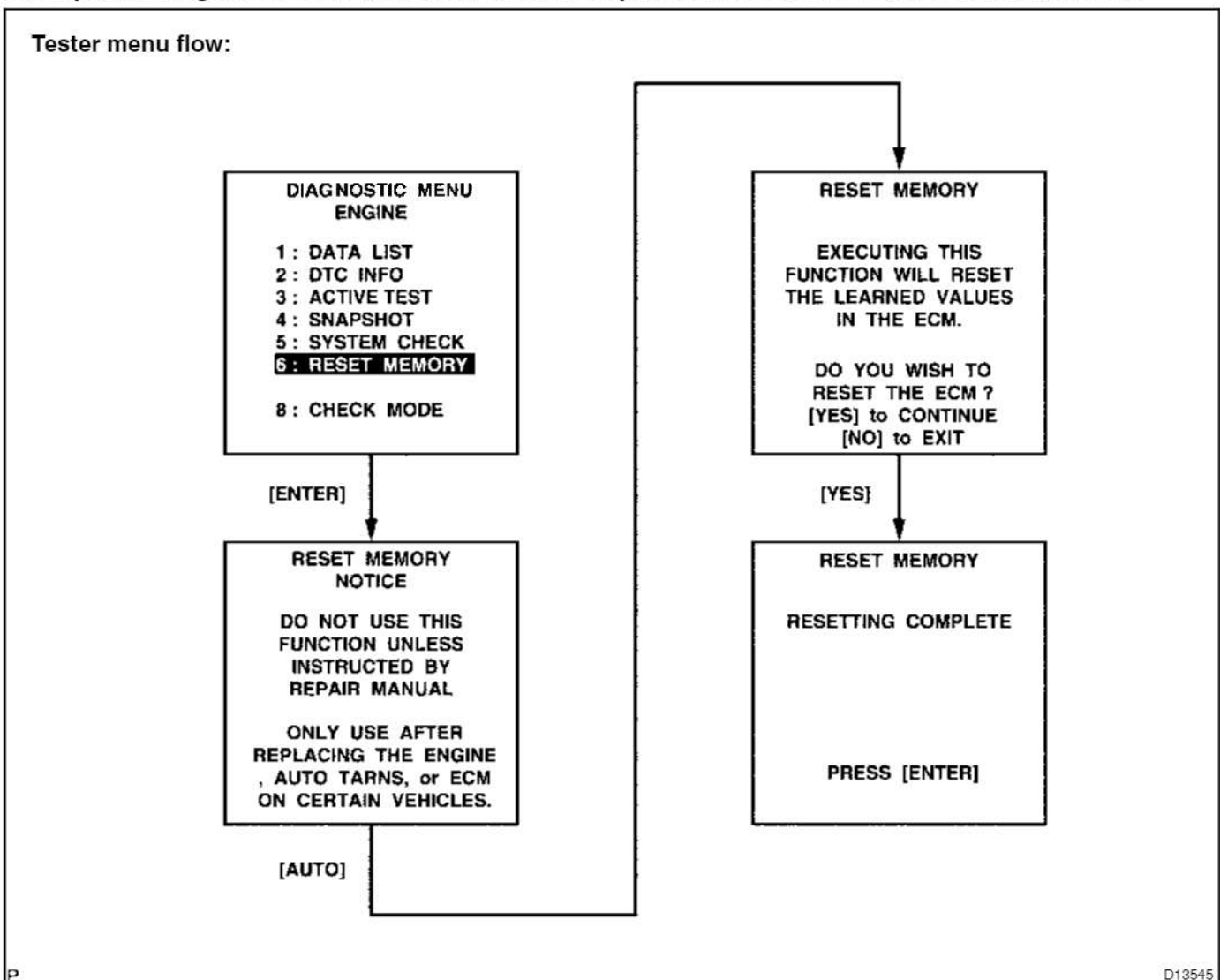

ABS & HYDRAULIC BRAKE BOOSTER POWER SUPPLY SYSTEM

HOW TO PROCEED WITH TROUBLESHOOTING

DI-53-01

Troubleshoot in accordance with the procedure on the following pages.

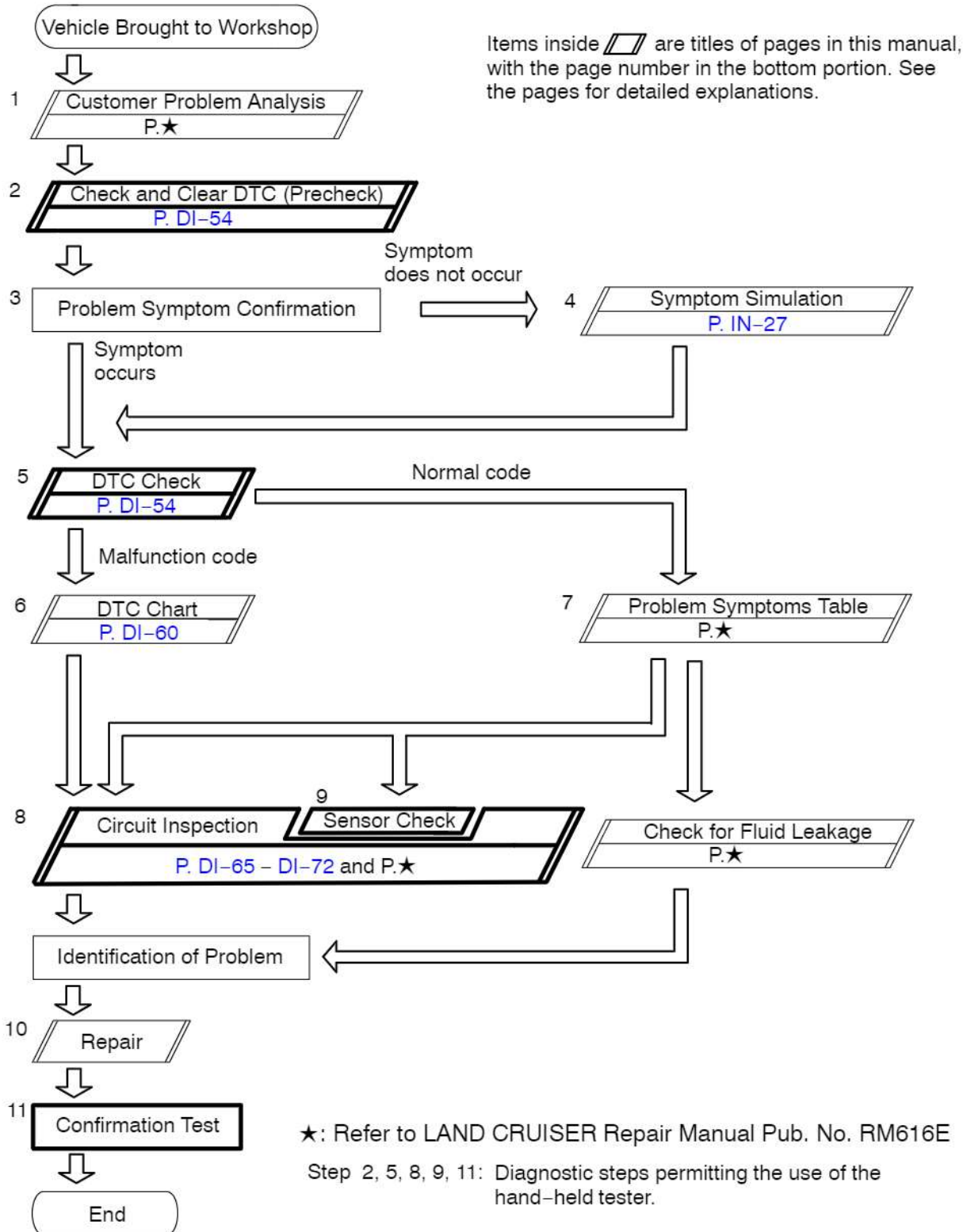

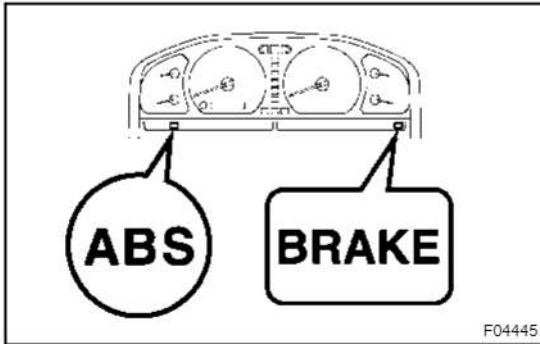

PRE-CHECK

1. DIAGNOSIS SYSTEM

- (a) Check the warning lights and buzzer.
 - (1) Release the parking brake lever.
 - (2) When the ignition switch is turned ON, check that the ABS warning lights come on for 3 seconds.
 - (3) Check the BRAKE warning light lights up when the ignition switch is turned ON and the light goes off when the engine starts.
 - (4) When 120 seconds have elapsed after the ignition switch was turned ON, depressing and releasing the brake pedal continuously with full stroke 15 - 20 times within 10 secs., warning light lights up and buzzer sounds.

HINT:

If the indicator check result is not normal, proceed to troubleshooting for the ABS warning light circuit (see Pub. No. RM616E, page DI-395).

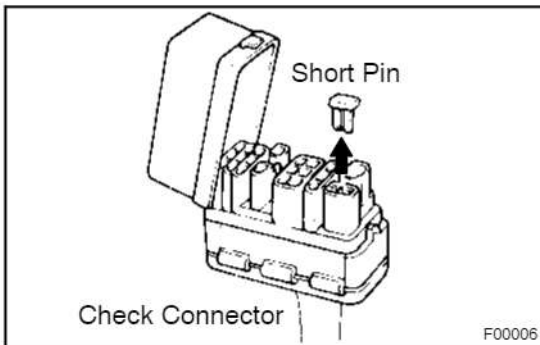

- (b) In case of not using hand-held tester:
 - (1) Disconnect the short pin from the check connector.

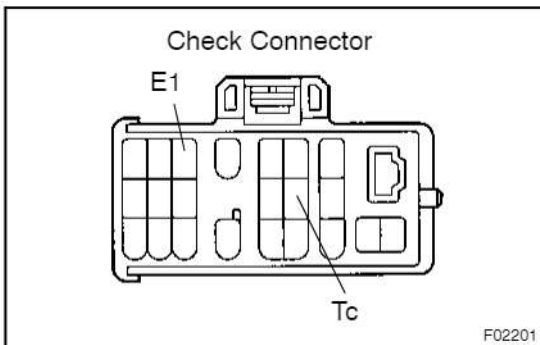

- (2) Using SST, connect terminals Tc and E₁ of the check connector.

SST 09843-18020

- (3) Turn the ignition switch to the ON position.
- (4) Read the DTC from the ABS warning light on the combination meter.

HINT:

If no code appears, inspect the diagnostic circuit or ABS warning light circuit (see Pub. No. RM616E, page DI-395).

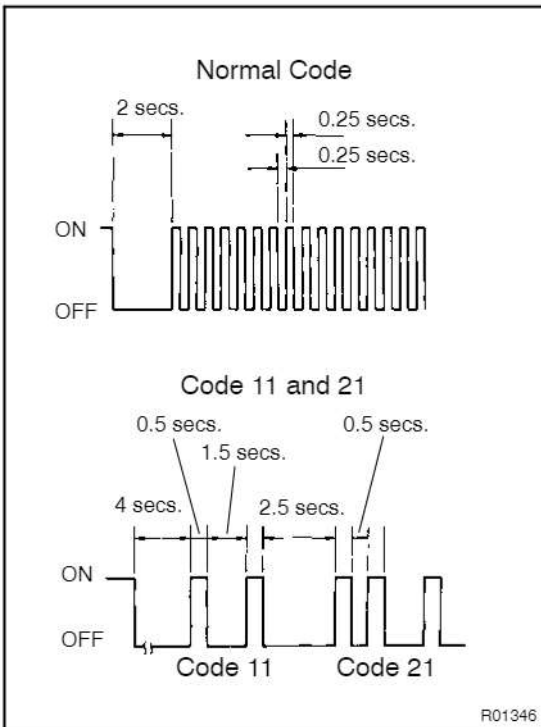

- As an example, the blinking patterns for a normal code and codes 11 and 21 are shown on the left.
 - Codes are explained in the code table on [page DI-60](#).
 - After completing the check, disconnect terminals Tc and E₁, and turn off the display.

If 2 or more malfunctions are indicated at the same time the lowest numbered DTC will be displayed 1st.

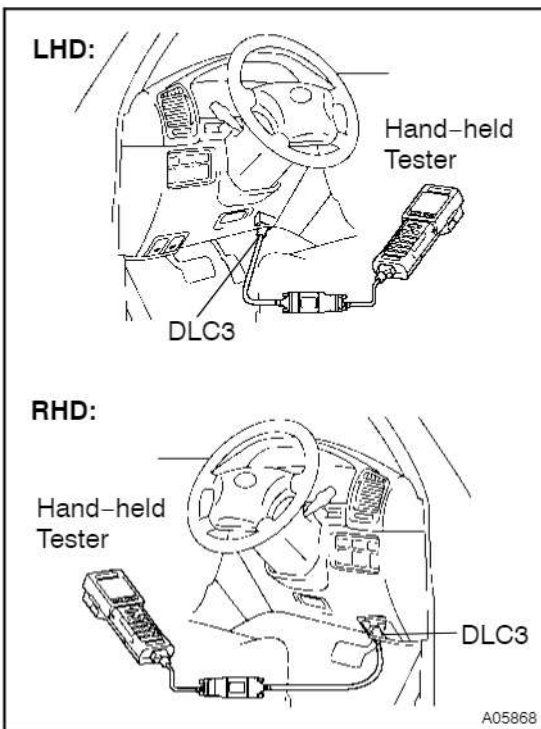

- In case of using hand-held tester:
 - Check the DTC.
 - Connect the hand-held tester to the DLC3.
 - Read the DTC by following the prompts on the tester screen.

HINT:
Please refer to the hand-held tester operator's manual for further details.

- In case of not using hand-held tester:
 - Clear the DTC.
 - Using SST, connect terminals Tc and E₁ of the check connector and remove the short pin from the check connector.
 - SST 09843-18020
 - Turn the ignition switch to the ON position.

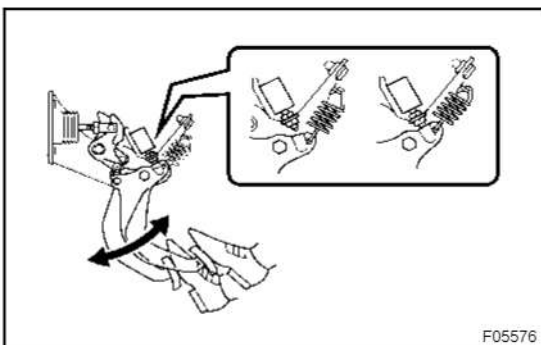

- Clear the DTC stored in the ECU by depressing the brake pedal 8 or more times within 5 seconds.
- Check that the warning light shows the normal code.

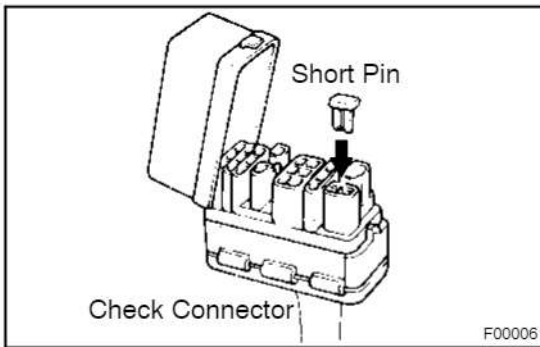

- (5) Remove the SST from the terminals of the check connector.

SST 09843-18020

- (6) Connect the short pin to the check connector.

HINT:

Disconnecting the battery cable during repairs will not erase the DTC in the ECU.

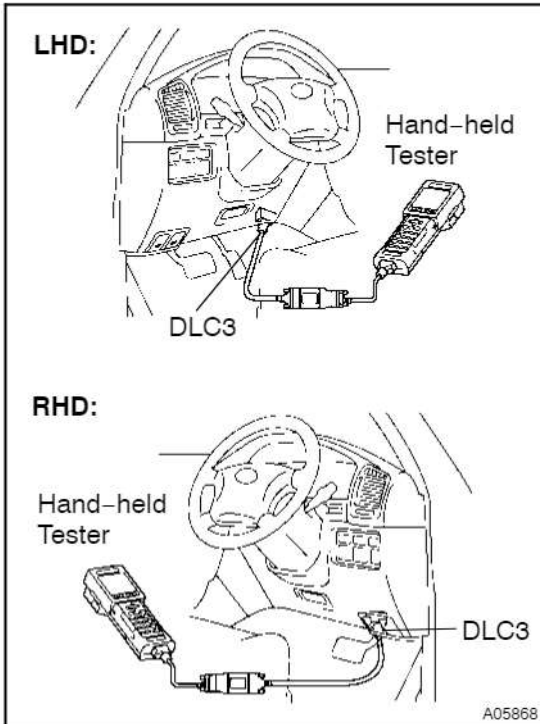

- (e) In case of using hand-held tester:
Clear the DTC.

- (1) Hook up the hand-held tester to the DLC3.
- (2) Turn the ignition switch to the ON position.
- (3) Operate the hand-held tester to erase the codes.
(See the hand-held tester operator's manual.)

2. SENSOR SIGNAL CHECK (TEST MODE)

HINT:

If the ignition switch is turned from the ON position to the ACC or LOCK position during test mode, DTC will be erased.

- (a) In case of using hand-held tester:

Check the sensor signal.

- (1) Turn the ignition switch OFF.
- (2) Connect the hand-held tester to the DLC3.
- (3) Start the engine.

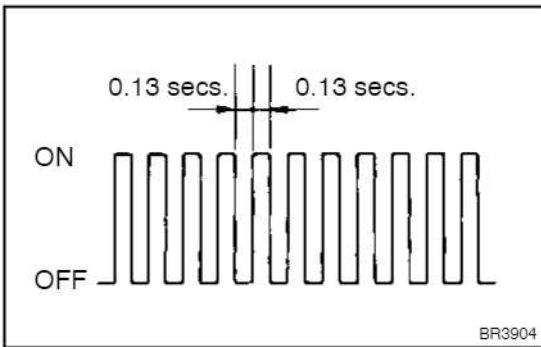

- (4) Check that the ABS warning light blinks.

HINT:

If the ABS warning light does not blink, inspect the ABS warning light circuit.

- (5) Keep the vehicle in the stationary condition on the flat place for 6 sec. or more.
- (6) Shift the transfer lever in the L4 position and turn the center differential lock switch ON.
- (7) Drive the vehicle straightforward.
When driving the vehicle with the speed faster than 45 km/h (28 mph) for several seconds, check that the ABS warning light goes off.

HINT:

The sensor check is not completed if the vehicle has its rear wheels spun or its turned wheel steered during this check.

- (8) Stop the vehicle.
- (9) Check that the ABS warning light goes off when the rear differential lock indicator light lights up or flashes.

HINT:

While the rear differential is being locked, the ECU records DTC C1248/48.

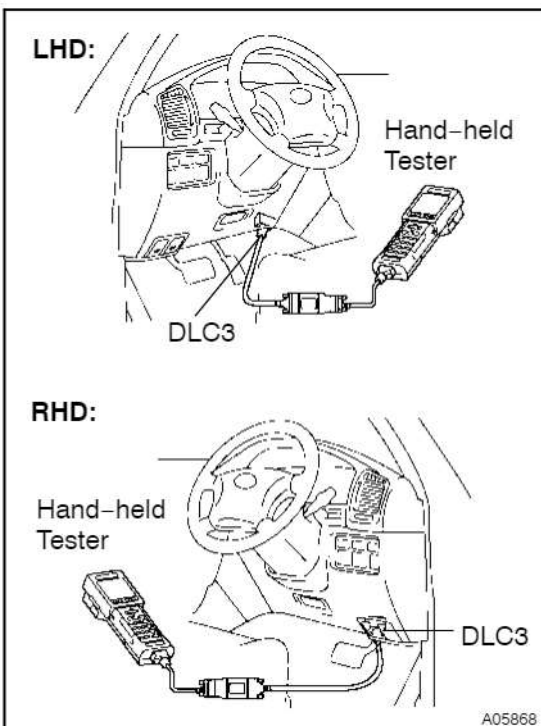

- (10) Read the DTC by following the prompts on the tester screen.

HINT:

Please refer to the hand-held tester operator's manual for further details.

DTC of the sensor check function:

Code No.	Diagnosis	Trouble Area
C1271 / 71	Low output voltage in right front speed sensor	<ul style="list-style-type: none"> • Right front speed sensor • Sensor installation • Sensor rotor
C1272 / 72	Low output voltage in left front speed sensor	<ul style="list-style-type: none"> • Left front speed sensor • Sensor installation • Sensor rotor
C1273 / 73	Low output voltage in right rear speed sensor	<ul style="list-style-type: none"> • Right rear speed sensor • Sensor installation • Sensor rotor
C1274 / 74	Low output voltage in left rear speed sensor	<ul style="list-style-type: none"> • Left rear speed sensor • Sensor installation • Sensor rotor
C1275 / 75	Abnormal change in output voltage of right front speed sensor	<ul style="list-style-type: none"> • Right front speed sensor rotor
C1276 / 76	Abnormal change in output voltage of left front speed sensor	<ul style="list-style-type: none"> • Left front speed sensor rotor
C1277 / 77	Abnormal change in output voltage of right rear speed sensor	<ul style="list-style-type: none"> • Right rear speed sensor rotor
C1278 / 78	Abnormal change in output voltage of left rear speed sensor	<ul style="list-style-type: none"> • Left rear speed sensor rotor
C1279 / 79	Deceleration sensor is faulty	<ul style="list-style-type: none"> • Deceleration sensor • Sensor installation
C1282 / 82	Center differential lock position switch malfunction	<ul style="list-style-type: none"> • Center differential lock position switch
C1282 / 83	L4 position switch malfunction	<ul style="list-style-type: none"> • L4 position switch

3. DECELERATION SENSOR OPERATION DIAGNOSIS SYSTEM

CAUTION:

While checking the deceleration sensor operating diagnosis system, ABS does not work and the brake system works as a conventional brake system.

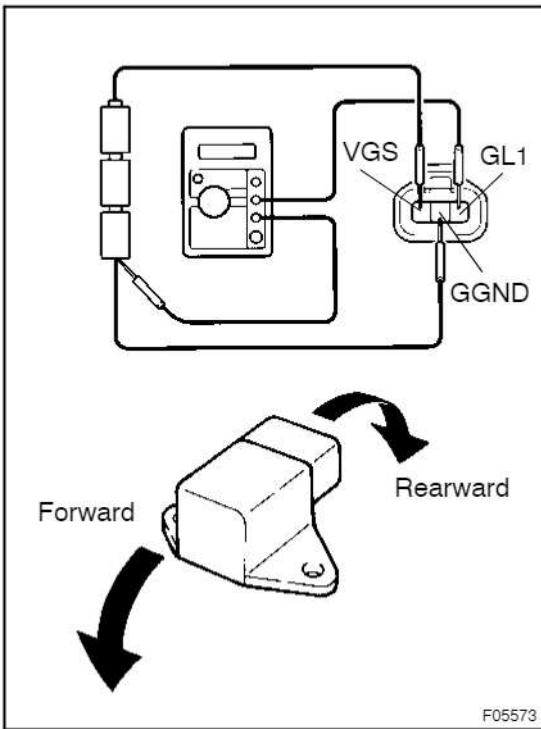

4. DECELERATION SENSOR CHECK

- (a) Connect 3 dry batteries of 1.5 V in series.
- (b) Connect VGS terminal to the batteries' positive (+) terminal, and GGND terminal to the batteries' negative (-) terminal. Apply about 4.5 V between VGS and GGND terminals.

NOTICE:

Do not apply voltage of 6 V or more to terminals VGS and GGND.

- (c) Check the output voltage of GL1 terminals.

Symbols	Condition	Standard Value
GL1	Horizontal	About 2.3 V
GL1	Lean forward	0.4 V to about 2.3 V
GL1	Lean rearward	About 2.3 V to 4.1 V

HINT:

- If the sensor is tilted too much, it may show the wrong value.
- If dropped, the sensor should be replaced with a new one.
- The sensor removed from the vehicle should not be placed upside down.

DIAGNOSTIC TROUBLE CODE CHART**NOTICE:****When removing the part, turn the ignition switch OFF.****HINT:**

- Using SST 09843 -18020, connect the terminals Tc and E₁, and remove the short pin.
- If any abnormality is not found when inspecting parts, inspect the ECU.
- If a malfunction code is displayed during the DTC check, check the circuit listed for that code. For details of each code, turn to the page referred to under the "See page" for respective "DTC No." in the DTC chart.

DTC No. (See Page)	Detection Item	Trouble Area
C0278 / 11 ★	Open or short in ABS solenoid relay circuit	<ul style="list-style-type: none"> • ABS solenoid relay • ABS solenoid relay circuit
C0279 / 12 ★	B+ short in ABS solenoid relay circuit	<ul style="list-style-type: none"> • ABS solenoid relay • ABS solenoid relay circuit
C0226 / 21 ★	Open or short in hydraulic brake booster solenoid circuit (SFR circuit)	<ul style="list-style-type: none"> • Hydraulic brake booster • SFRR or SFRH circuit
C0236 / 22 ★	Open or short in hydraulic brake booster solenoid circuit (SFL circuit)	<ul style="list-style-type: none"> • Hydraulic brake booster • SFLR or SFLH circuit
C0246 / 23 ★	Open or short in hydraulic brake booster solenoid circuit (SRR circuit)	<ul style="list-style-type: none"> • Hydraulic brake booster • SRH or SRR circuit
C1225 / 25 ★	Open or short in hydraulic brake booster solenoid circuit (SA1 circuit)	<ul style="list-style-type: none"> • Hydraulic brake booster • SA1 circuit
C1226 / 26 ★	Open or short in hydraulic brake booster solenoid circuit (SA2 circuit)	<ul style="list-style-type: none"> • Hydraulic brake booster • SA2 circuit
C0200 / 31*1 (DI-79)	Right front wheel speed sensor signal malfunction	<ul style="list-style-type: none"> • Right front speed sensor • Speed sensor circuit • Sensor rotor
C0205 / 32*1 (DI-65)	Left front wheel speed sensor signal malfunction	<ul style="list-style-type: none"> • Left front speed sensor • Speed sensor circuit • Sensor rotor
C0210 / 33*1 (DI-65)	Right rear wheel speed sensor signal malfunction	<ul style="list-style-type: none"> • Right rear speed sensor • Speed sensor circuit • Sensor rotor
C0215 / 34*1 (DI-65)	Left rear wheel speed sensor signal malfunction	<ul style="list-style-type: none"> • Left rear speed sensor • Speed sensor circuit • Sensor rotor
C1237 / 37 ★	Some tire is different size from the other tires	<ul style="list-style-type: none"> • Tire size
C1241 / 41 ★	Low battery voltage or open circuit in IG1 circuit	<ul style="list-style-type: none"> • Battery • IC regulator • Power source circuit
C1242 / 42 ★	Open circuit in IG2 circuit	<ul style="list-style-type: none"> • Battery • IC regulator • Power source circuit
C1243 / 43 ★	Malfunction in deceleration sensor (constant output)	<ul style="list-style-type: none"> • Deceleration sensor • Wire harness for deceleration sensor system
C1244 / 44 ★	Open or short circuit in deceleration sensor circuit	<ul style="list-style-type: none"> • Deceleration sensor • Deceleration sensor circuit
C1245 / 45 ★	Malfunction in deceleration sensor	<ul style="list-style-type: none"> • Deceleration sensor • Wire harness for deceleration sensor system

C1248 / 48 ★	<ul style="list-style-type: none"> • Open or short circuit in rear differential lock circuit • Rear differential is locking 	<ul style="list-style-type: none"> • Rear differential lock
C1249 / 49 ★	Open circuit in stop light switch circuit	<ul style="list-style-type: none"> • Stop light switch circuit
C1251 / 51*2 ★	<ul style="list-style-type: none"> • Pump motor is locked • Open circuit in pump motor ground 	<ul style="list-style-type: none"> • Hydraulic brake booster pump motor
C1252 / 52*2 ★	Hydraulic brake booster pump motor malfunction	<ul style="list-style-type: none"> • Hydraulic brake booster pump motor • Hydraulic brake booster pump motor circuit • Pressure switch (PH or PL)
C1253 / 53*2 ★	Hydraulic brake booster pump motor relay malfunction	<ul style="list-style-type: none"> • ABS motor relay • ABS motor relay circuit
C1254 / 54*2 ★	Pressure switch malfunction	<ul style="list-style-type: none"> • Pressure switch (PH or PL) • Pressure switch circuit
C1256 / 56*2 ★	Accumulator low pressure malfunction	<ul style="list-style-type: none"> • Accumulator • Pressure switch (PH or PL) • Hydraulic brake booster pump motor
C1257 / 57*2 ★	Power supply drive circuit malfunction	<ul style="list-style-type: none"> • Battery • Power Source circuit • ABS ECU
Always ON ★	Malfunction in ABS ECU	<ul style="list-style-type: none"> • Battery • IC regulator • Power source circuit • ABS ECU

*1: As the DTC cannot be erased by replacing parts alone do either of the following operations.

- (1) Clear the DTC (See page DI-54).
- (2) At a vehicle speed of 20 km/h (12 mph), drive the vehicle for 30 seconds or more.

*2: Using the following table, troubled parts can be specified.

★: Refer to LAND CRUISER Repair Manual Pub. No. RM616E

DTC		42		51		52		53		54		56		57	
BRAKE warning light and buzzer		Light	Buzzer	Light	Buzzer	Light	Buzzer	Light	Buzzer	Light	Buzzer	Light	Buzzer	Light	Buzzer
Pressure switch	PH					○	○			○		○	○		
	PL					○	○			○		○	○		
Pump motor circuit	Pump motor			○	○	○	○					○	○		
	MTT wire harness					○	○	○							
	MT+ wire harness			○											
	MT- wire harness			○											
Accumulator malfunction												○	○		
Motor relay circuit	MR1 open circuit							○							
	MR2 open circuit							○							
	MR1 welded contact					○	○	○							
	MR2 welded contact					○	○	○							
Hydraulic brake booster	Pressure leaks					○	○					○	○		
Power source*	IG2 open circuit	○													
ECU	Power supply circuit													○	

*: When IG1 circuit is open, the ABS warning light and BRAKE warning light come on.

TERMINALS OF ECU

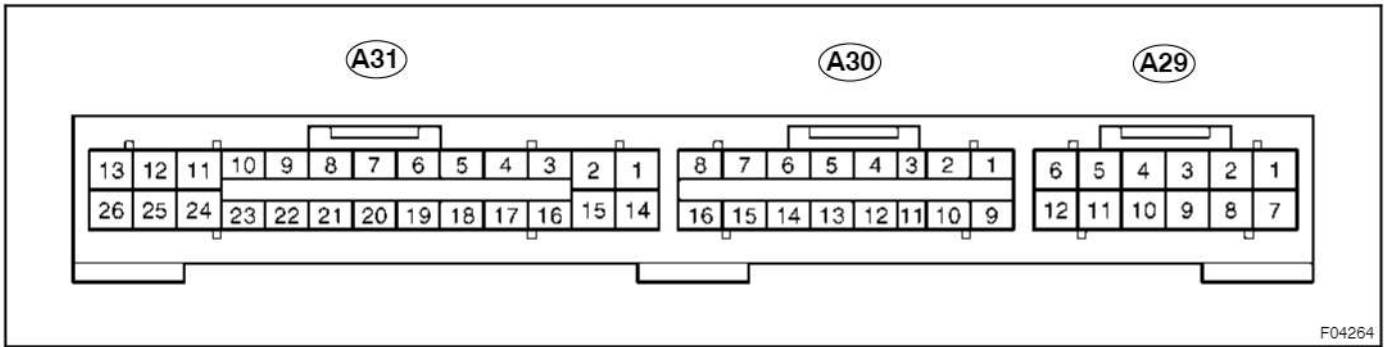

F04264

Symbols (Terminals No.)	Wiring Color	Condition	STD Voltage (V)
MT (A29 - 2) - GND (A31 - 2, 15, A29 - 1, 7)	B-R - W-B	IG switch ON (Motor relay is OFF)	Below 1.5
Tc (A29 - 4) - GND (A31 - 2, 15, A29 - 1, 7)	P-B - W-B	IG switch ON and terminals Tc-E ₁ of check connector connected	Below 1.5
Tc (A29 - 4) - GND (A31 - 2, 15, A29 - 1, 7)	P-B - W-B	IG switch ON and terminals Tc-E ₁ of check connector not connected	11 to 14
MR2 (A29 - 5) - GND (A31 - 2, 15, A29 - 1, 7)	Y-B - W-B	IG switch ON, hydraulic brake booster pump motor stops	11 to 14
IG2 (A29 - 6) - GND (A31 - 2, 15, A29 - 1, 7)	B-R - W-B	IG switch ON	11 to 14
PKB(A29-10) - GND (A31 - 2, 15, A29 - 1, 7)	R-W - W-B	IG switch ON, parking brake switch ON	Below 1
PKB(A29-10) - GND (A31 - 2, 15, A29 - 1, 7)	R-W - W-B	IG switch ON, parking brake switch OFF	10 to 14
VGS (A30 - 1) - GGND (A30 - 10)	R - B	IG switch ON	4.5 to 5.5
GL1 (A30 - 2) - GGND (A30 - 10)	W - B	IG switch ON, vehicle is placed on the horizontal surface	2.0 to 3.0
BRL (A30 - 3) - GND (A31 - 2, 15, A29 - 1, 7)	Y-G - W-B	IG switch ON, BRAKE warning light ON	Below 2.0
BRL (A30 - 3) - GND (A31 - 2, 15, A29 - 1, 7)	Y-G - W-B	IG switch ON, BRAKE warning light OFF	11 to 14
RR+ (A30 - 5) - RR- (A30 - 13)	B - W	IG switch ON, slowly turn right rear wheel	AC generation
EXI2 (A30 - 6) - GND (A31 - 2, 15, A29 - 1, 7)	*1: B-L - W-B *2: R-L - W-B	IG switch ON, REAR DIFF LOCK switch OFF	8 to 14
EXI2 (A30 - 6) - GND (A31 - 2, 15, A29 - 1, 7)	*1: B-L - W-B *2: R-L - W-B	IG switch ON, REAR DIFF LOCK switch OFF	8 to 14
EXI2 (A30 - 6) - GND (A31 - 2, 15, A29 - 1, 7)	*1: B-L - W-B *2: R-L - W-B	IG switch ON, REAR DIFF LOCK switch ON	Below 2.0
EX1 (A30 - 7) - GND (A31 - 2, 15, A29 - 1, 7)	P-B - W-B	IG switch ON, CENTER DIFF LOCK switch OFF	11 to 14
EX1 (A30 - 7) - GND (A31 - 2, 15, A29 - 1, 7)	P-B - W-B	IG switch ON, CENTER DIFF LOCK switch ON	Below 2.0
SR (A30 - 8) - GND (A31 - 2, 15, A29 - 1, 7)	G-Y - W-B	IG switch ON, ABS warning light OFF	11 to 14

BZ (A30 - 11) - GND (A31 - 2, 15, A29 - 1, 7)	L - W-B	IG switch ON, BRAKE buzzer sounds	Below 1.5
BZ (A30 - 11) - GND (A31 - 2, 15, A29 - 1, 7)	L - W-B	IG switch ON, BRAKE buzzer does not sound	11 to 14
RL+ (A30 - 12) - RL- (A30 - 4)	R - G	IG switch ON, slowly turn left rear wheel	AC generation
EXI3 (A30 - 14) - GND (A31 - 2, 15, A29 - 1, 7)	B-L - W-B	IG switch ON, transfer in L position	8 to 14
EXI3 (A30 - 14) - GND (A31 - 2, 15, A29 - 1, 7)	B-L - W-B	IG switch ON, transfer in any position except L position	Below 1.5
SA1 (A31 - 1) - GND (A31 - 2, 15, A29 - 1, 7)	G - W-B	IG switch ON, ABS warning light OFF	11 to 14
MT+ (A31 - 3) - MT- (A31 - 16)	L - GR	IG switch ON, pump motor dose not operate	Below 1
FR+ (A31 - 5) - FR- (A31 - 18)	L - P	IG switch ON, slowly turn right front wheel	AC generation
MR1 (A31 - 7) - GND (A31 - 2, 15, A29 - 1, 7)	R - W-B	IG switch ON, hydraulic brake booster pump motor stops	11 to 14
WA (A31 - 8) - GND (A31 - 2, 15, A29 - 1, 7)	R-L - W-B	IG switch ON, ABS warning light ON	Below 2.0
WA (A31 - 8) - GND (A31 - 2, 15, A29 - 1, 7)	R-L - W-B	IG switch ON, ABS warning light OFF	11 to 14
IG1 (A31 - 10) - GND (A31 - 2, 15, A29 - 1, 7)	B-W - W-B	IG switch ON	11 to 14
SRH (A31 - 11) - GND (A31 - 2, 15, A29 - 1, 7)	W - W-B	IG switch ON, ABS warning light OFF	11 to 14
SFLH (A31 - 12) - GND (A31 - 2, 15, A29 - 1, 7)	Y - W-B	IG switch ON, ABS warning light OFF	11 to 14
SFRH (A31 - 13) - GND (A31 - 2, 15, A29 - 1, 7)	LG - W-B	IG switch ON, ABS warning light OFF	11 to 14
SA2 (A31 - 14) - GND (A31 - 2, 15, A29 - 1, 7)	B - W-B	IG switch ON, ABS warning light OFF	11 to 14
FL+ (A31 - 17) - FL- (A31 - 4)	R - G	IG switch ON, slowly turn left front wheel	AC generation
PH (A31 - 20) - GND (A31 - 2, 15, A29 - 1, 7)	O - W-B	IG switch ON, pressure switch (PH) ON	5 to 8
PH (A31 - 20) - GND (A31 - 2, 15, A29 - 1, 7)	O - W-B	IG switch ON, pressure switch (PH) OFF	Below 0.9
D/G (A31 - 21) - GND (A31 - 2, 15, A29 - 1, 7)	V-W - W-B	IG switch ON	11 to 14
STP (A31 - 22) - GND (A31 - 2, 15, A29 - 1, 7)	G-W - W-B	Stop light switch OFF	Below 1.5
STP (A31 - 22) - GND (A31 - 2, 15, A29 - 1, 7)	G-W - W-B	Stop light switch ON	8 to 14
SRR (A31 - 24) - GND (A31 - 2, 15, A29 - 1, 7)	B-O - W-B	IG switch ON, ABS warning light OFF	11 to 14
SFLR (A31 - 25) - GND (A31 - 2, 15, A29 - 1, 7)	B-Y - W-B	IG switch ON, ABS warning light OFF	11 to 14
SFRR (A31 - 26) - GND (A31 - 2, 15, A29 - 1, 7)	B-W - W-B	IG switch ON, ABS warning light OFF	11 to 14
PL (A29 - 11) - GND (A31 - 2, 15, A29 - 1, 7)	W - W-B	IG switch ON, pressure switch (PL) ON	7 to 10

PL (A29 - 11) - GND (A31 - 2, 15, A29 - 1, 7)	W - W-B	IG switch ON, pressure switch (PL) OFF	3 to 5
R2+ (A29 - 12) - GND (A31 - 2, 15, A29 - 1, 7)	W-L - W-B	IG switch ON, pump motor dose not operate	11 to 14
R+ (A30 - 16) - GND (A31 - 2, 15, A29 - 1, 7)	G-O - W-B	IG switch ON, pump motor dose not operate	11 to 14
R1+ (A31 - 9) - GND (A31 - 2, 15, A29 - 1, 7)	P - W-B	IG switch ON, pump motor dose not operate	11 to 14

*1: LHD

*2: RHD

CIRCUIT INSPECTION

DTC	C0200 / 31 to C0215 / 34	Speed Sensor Circuit
------------	---------------------------------	-----------------------------

CIRCUIT DESCRIPTION

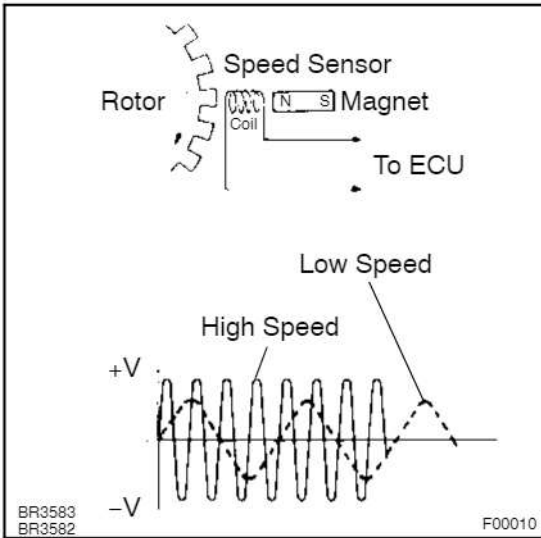

The speed sensor detects wheel speed and sends the appropriate signals to the ECU. These signals are used for control of the ABS control system. The front and rear rotors each have 48 serrations.

When the rotors rotate, the magnetic field emitted by the permanent magnet in the speed sensor generates AC voltage. Since the frequency of this AC voltage changes in direct proportion to the speed of the rotor, the frequency is used by the ECU to detect the speed of each wheel.

DTC No.	DTC Detecting Condition	Trouble Area
C0200 / 31 C0205 / 32 C0210 / 33 C0215 / 34	Detection of any of the conditions 1. through 4.: 1. At a vehicle speed of 10 km/h (6 mph) or more, pulses are not input for 15 sec. 2. Momentary interruption of the speed sensor signal occurs at least 7 times in the time between switching the ignition switch ON and switching it OFF. 3. Continuous noise occurs into the speed sensor signals with a vehicle speed at 20 km/h (12 mph) or more. 4. The condition that the speed sensor signal circuit is open continues for 0.12 sec. or more. •ABS does not function •Brake pedal is not depressed •Parking brake is not set •Rear differential does not lock Under the above conditions, when the difference in velocity between the highest rotating and the second highest rotating wheels is within 2 km/h (1.2 mph), the slowest wheel rotates at 0 km/h (0 mph), and the second slowest wheel rotates at 12 km/h (7.5 mph) for 1 second or more.	•Right front, left front, right rear and left rear speed sensor •Each speed sensor circuit •Sensor rotor

HINT:

DTC No. C0200 / 31 are for the right front speed sensor.

DTC No. C0205 / 32 are for the left front speed sensor.

DTC No. C0210 / 33 are for the right rear speed sensor.

DTC No. C0215 / 34 are for the left rear speed sensor.

Fail safe function:

If trouble occurs in the speed sensor circuit, the ECU cuts off current to the ABS solenoid relay and prohibits ABS control and the brake system becomes normal.

WIRING DIAGRAM

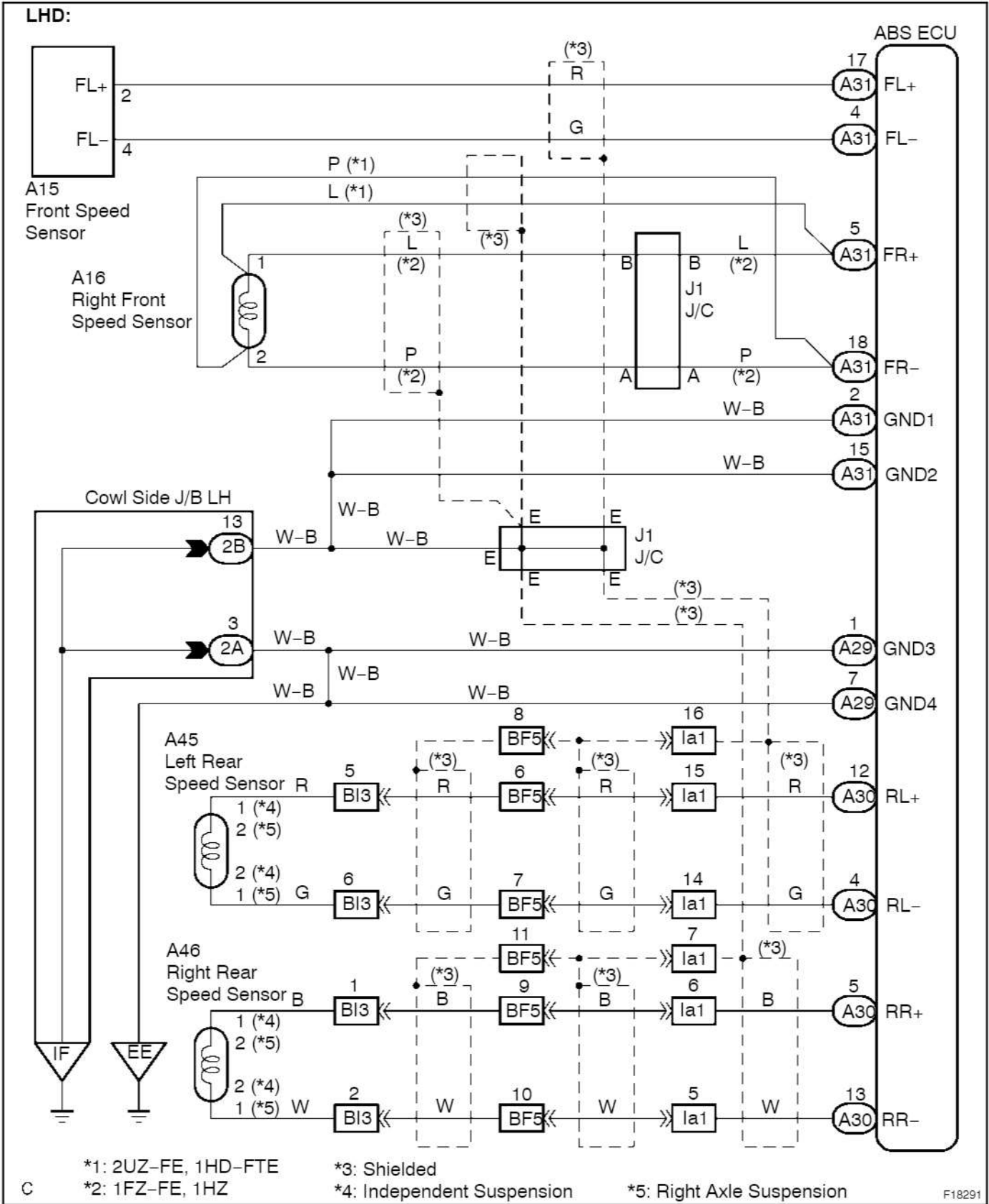

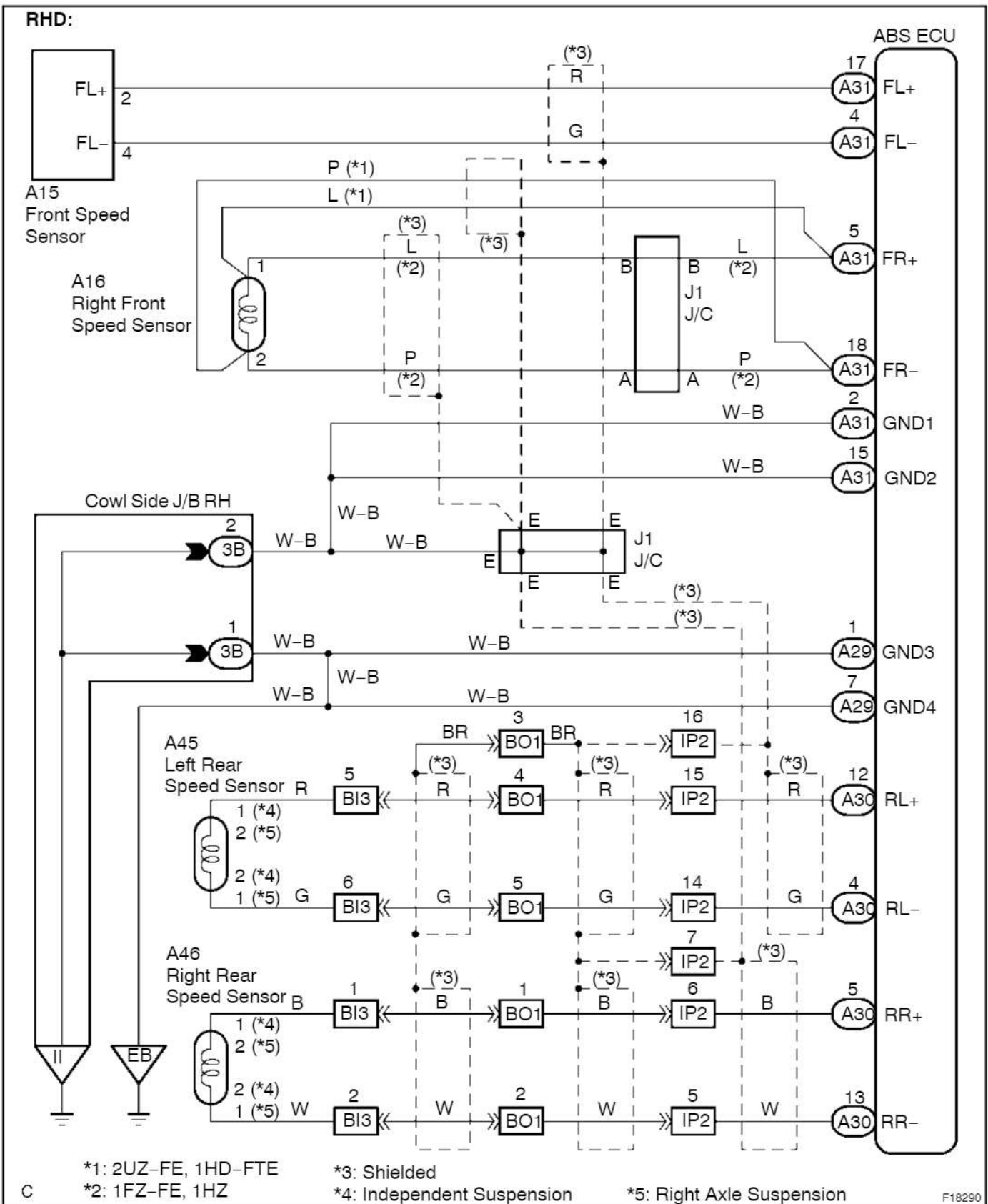

INSPECTION PROCEDURE

Start the inspection from step 1 when using the hand-held tester and start from step 2 when not using the hand-held tester.

1 Check output value of speed sensor.

PREPARATION:

- Connect the hand held tester to the DLC3.
- Turn the ignition switch to the ON position and push the hand-held tester main switch ON.
- Select the DATA LIST mode on the hand-held tester.

CHECK:

Check that there is no difference between the speed value output from the speed sensor displayed on the hand-held tester and the speed value displayed on the speedometer when driving the vehicle.

OK:

There is almost no difference between displayed speed value.

HINT:

There is tolerance of $\pm 10\%$ in the speedometer indication.

OK

Check and replace ABS ECU.

NG

2 Check speed sensor.

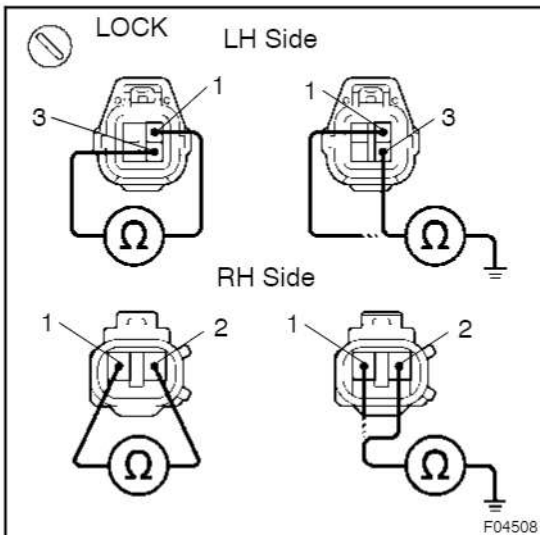

FRONT:

PREPARATION:

- Make sure that there is no looseness at the connector's locking part and connecting part of the connector.
- Disconnect the speed sensor connector.

CHECK:

LH Side:

Measure resistance between terminals 1 and 3 of the speed sensor connector.

RH side:

Measure resistance between terminals 1 and 2 of the speed sensor connector.

OK:

Resistance: 0.92 to 1.22 kΩ

CHECK:

LH Side:

Measure resistance between terminal 1 or 3 of the speed sensor connector and body ground.

RH Side:

Measure resistance between terminal 1 or 2 of the speed sensor connector and body ground.

OK:

Resistance: 10 kΩ or higher

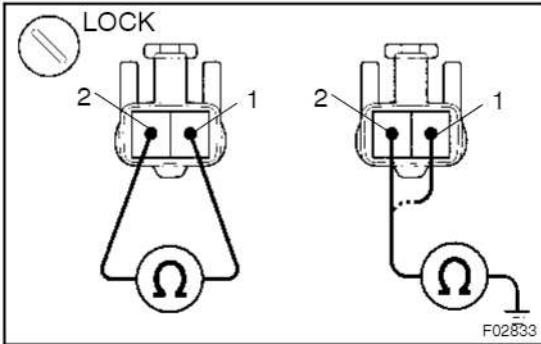

REAR:

PREPARATION:

- (a) Make sure that there is no looseness at the connector's locking part and connecting part of the connector.
- (b) Disconnect speed sensor connector.

CHECK:

Measure resistance between terminals 1 and 2 of the speed sensor connector.

OK:

Resistance: 1.0 to 1.4 kΩ

CHECK:

Measure resistance between terminal 1 or 2 of the speed sensor connector and body ground.

OK:

Resistance: 10 kΩ or higher

NG	Replace speed sensor.
-----------	------------------------------

NOTICE:

Check the speed sensor signal after replacement (See page DI-54).

OK

3	Check for open and short circuit in harness and connector between each speed sensor and ECU (See page IN-38).
----------	--

NG	Repair or replace harness or connector.
-----------	--

OK

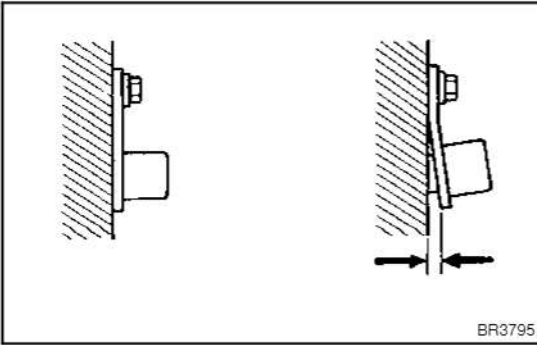
4 Check sensor installation.**CHECK:**

Check the speed sensor installation.

OK:

The installation bolt is tightened properly and there is no clearance between the sensor and front steering knuckle or rear axle carrier.

Torque: (Front speed sensor)
8.0 N·m (82 kgf·cm, 71 in·lbf)

NG**Replace speed sensor.****NOTICE:**

Check the speed sensor signal after replacement (See page DI-54).

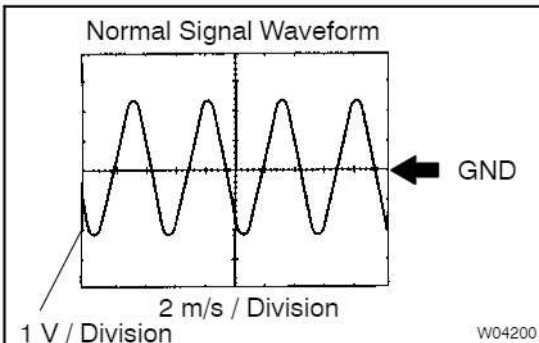
OK**5 Check speed sensor and sensor rotor serrations.****(REFERENCE) INSPECTION USING OSCILLOSCOPE****PREPARATION:**

- Remove the ABS ECU.
- Connect the oscilloscope to each of terminals FR+, FL+, RR+ or RL+ and GND of the ABS ECU.

CHECK:

Drive the vehicle at about 20 km/h (12 mph), and check the signal waveform.

OK:

A waveform as shown in a figure should be output.

HINT:

- As vehicle speed (wheel revolution speed) increases, a cycle of waveform narrows and the fluctuation in the output voltage becomes greater.
- When noise is identified in the waveform on the oscilloscope, error signals are generated due to the speed sensor rotors scratches, looseness or foreign matter on it.

OK**Check and replace ABS ECU.****NG**

6 Check sensor rotor and sensor tip.

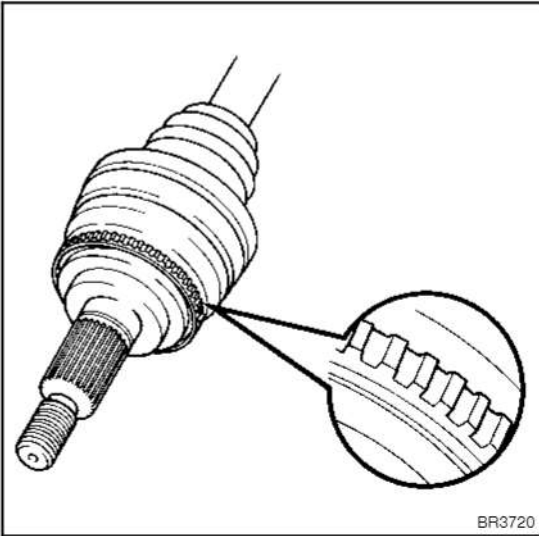

FRONT:

PREPARATION:

- (a) RFS:
Remove the steering axle shaft.
- (b) IFS:
Remove the front drive shaft.

CHECK:

Check the sensor rotor serrations.

OK:

No foreign matter or missing teeth.

PREPARATION:

Remove the front speed sensor.

CHECK:

Check the sensor tip.

OK:

No foreign matter on the sensor tip.

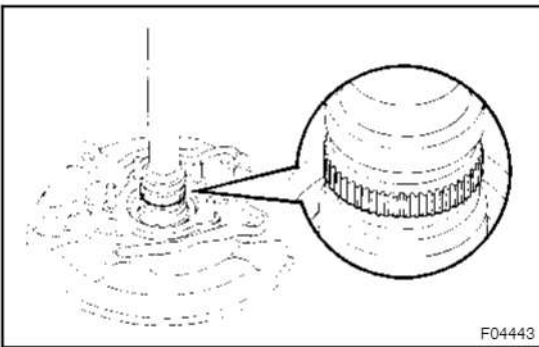

REAR:

PREPARATION:

- (a) RFS:
Remove the rear axle hub.
- (b) IFS:
Remove the rear axle shaft.

CHECK:

Check the sensor rotor serrations.

OK:

No foreign matter or missing teeth.

PREPARATION:

Remove the rear speed sensor.

CHECK:

Check the sensor tip.

OK:

No foreign matter on the sensor tip.

NG

Replace speed sensor or rotor.

NOTICE:

Check the speed sensor signal after replacement (See page DI-54).

OK

Check and replace ABS ECU.

BRAKE Warning Light Circuit

CIRCUIT DESCRIPTION

The BRAKE warning light lights up when the brake fluid is insufficient and an abnormality occurs in the hydro brake booster.

WIRING DIAGRAM

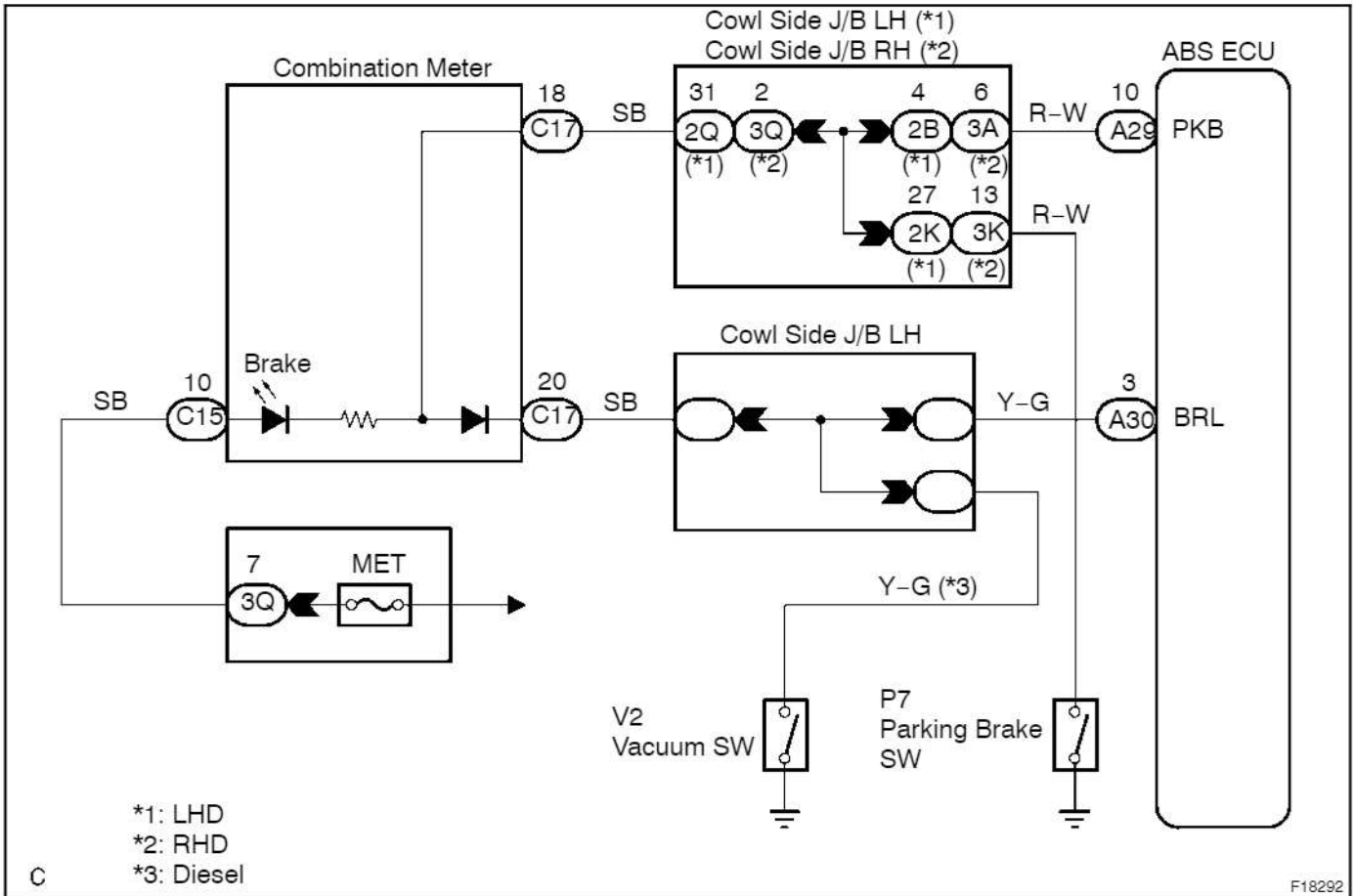

INSPECTION PROCEDURE

- 1 Check parking brake switch circuit.

NG

Repair or replace parking brake switch circuit.

OK

2 Check brake fluid level warning switch circuit.

NG Repair or replace brake fluid level warning switch circuit.

OK

3 Is DTC output for ABS ?

Check the DTC on [page DI-54](#).

Yes Repair circuit indicated by the output code.

No

4 Check BRAKE warning light.

See combination meter troubleshooting.

NG Repair or replace combination meter.

OK

5 Check multiplex communication system.

NG Repair or replace multiplex communication circuit.

OK

Check and replace ABS ECU.

cardiagn.com

ABS & VEHICLE STABILITY CONTROL (VSC) & BRAKE ASSIST (BA) SYSTEM

HOW TO PROCEED WITH TROUBLESHOOTING

DI6WY-05

Troubleshooting in accordance with the procedure on the following pages.

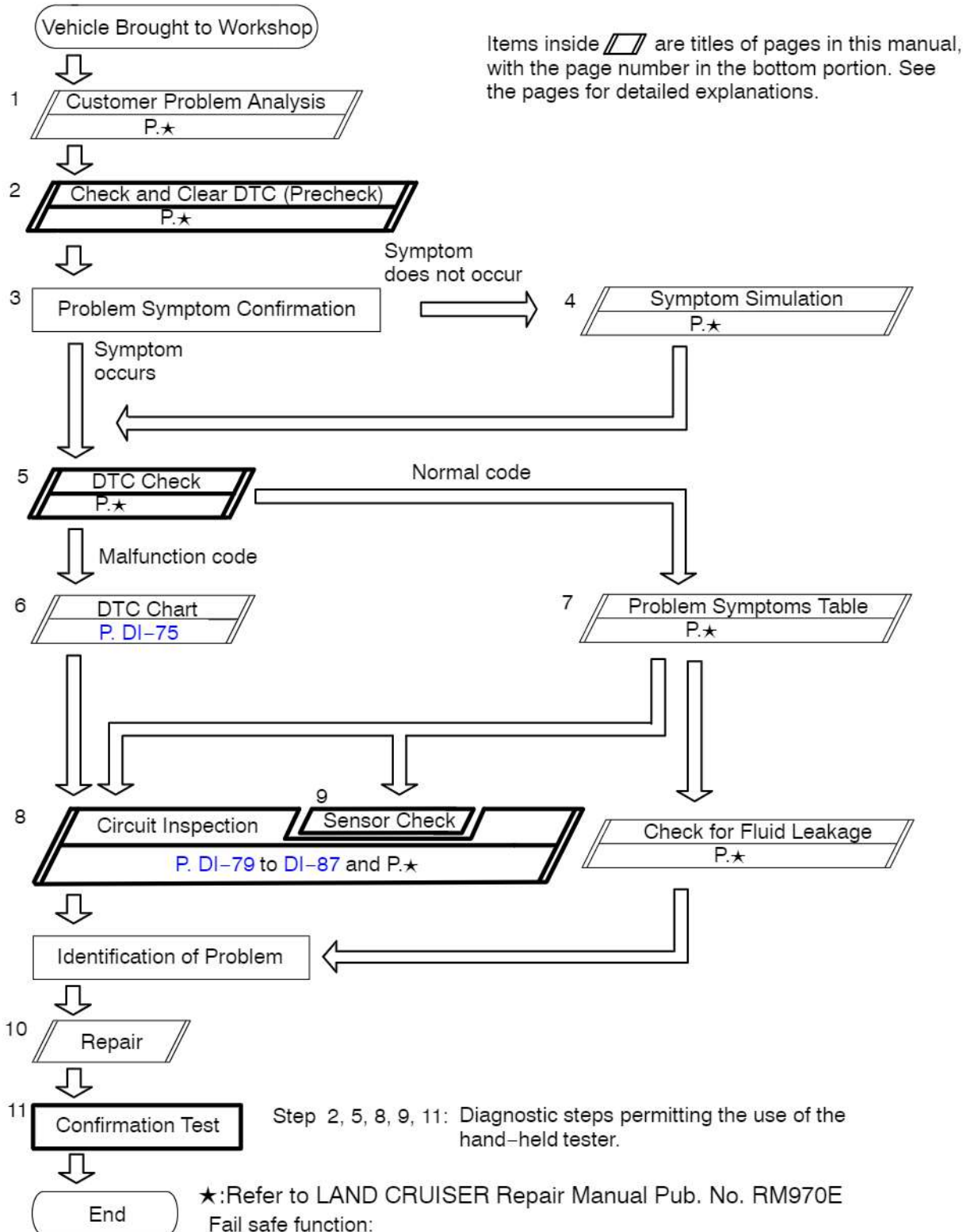

DIAGNOSTIC TROUBLE CODE CHART

NOTICE:

When removing the part, turn the ignition switch OFF.

HINT:

- Using SST 09843-18020, connect the terminals Tc and E₁ of the check connector.
- If any abnormality is not found when inspecting parts, inspect the ECU.
- If a malfunction code is displayed during the DTC check, check the circuit listed for that code. For details of each code, turn to the page referred to under the "See page" for respective "DTC No." in the DTC chart.

DTC chart of ABS:

DTC No. (See Page)	Detection Item	Trouble Area
C0278 / 11 ★	Open or short circuit in ABS solenoid relay circuit	<ul style="list-style-type: none"> • ABS solenoid relay • ABS solenoid relay circuit
C0279 / 12 ★	B+ short circuit in ABS solenoid relay circuit	<ul style="list-style-type: none"> • ABS solenoid relay • ABS solenoid relay circuit
C0226 / 21 ★	Open or short circuit in hydraulic brake booster solenoid circuit (SFR circuit)	<ul style="list-style-type: none"> • Hydraulic brake booster • SFRR or SFRH circuit
C0236 / 22 ★	Open or short circuit in hydraulic brake booster solenoid circuit (SFL circuit)	<ul style="list-style-type: none"> • Hydraulic brake booster • SFLR or SFLH circuit
C0246 / 23 ★	Open or short circuit in hydraulic brake booster solenoid circuit (SRR circuit)	<ul style="list-style-type: none"> • Hydraulic brake booster • SRRR or SRRH circuit
C0256 / 24 ★	Open or short circuit in hydraulic brake booster solenoid circuit (SRL circuit)	<ul style="list-style-type: none"> • Hydraulic brake booster • SRLR or SRLH circuit
C1225 / 25 ★	Open or short circuit in hydraulic brake booster solenoid circuit (SA1 circuit)	<ul style="list-style-type: none"> • Hydraulic brake booster • SA1 circuit
C1226 / 26 ★	Open or short circuit in hydraulic brake booster solenoid circuit (SA2 circuit)	<ul style="list-style-type: none"> • Hydraulic brake booster • SA2 circuit
C1227 / 27 ★	Open or short circuit in hydraulic brake booster solenoid circuit (SA3 circuit)	<ul style="list-style-type: none"> • Hydraulic brake booster • SA3 circuit
C1228 / 28 ★	Open or short circuit in hydraulic brake booster solenoid circuit (STR circuit)	<ul style="list-style-type: none"> • Hydraulic brake booster • STR circuit
C0200 / 31*1 (DI-79)	Right front wheel speed sensor signal malfunction	<ul style="list-style-type: none"> • Right front speed sensor • Speed sensor circuit • Sensor rotor
C0205 / 32*1 (DI-79)	Left front wheel speed sensor signal malfunction	<ul style="list-style-type: none"> • Left front speed sensor • Speed sensor circuit • Sensor rotor
C0210 / 33*1 (DI-79)	Right rear wheel speed sensor signal malfunction	<ul style="list-style-type: none"> • Right rear speed sensor • Speed sensor circuit • Sensor rotor
C0215 / 34*1 (DI-79)	Left rear wheel speed sensor signal malfunction	<ul style="list-style-type: none"> • Left rear speed sensor • Speed sensor circuit • Sensor rotor
C1235 / 35 (DI-79)	Foreign matter is attached on the tip of the right front sensor	<ul style="list-style-type: none"> • Right front speed sensor • Speed sensor rotor
C1236 / 36 (DI-79)	Foreign matter is attached on the tip of the left front sensor	<ul style="list-style-type: none"> • Left front speed sensor • Speed sensor rotor
C1237 / 37 ★	Some tire is different size from the other tires	Tire size

C1238 / 38 (DI-79)	Foreign matter is attached on the tip of the right rear sensor	<ul style="list-style-type: none"> • Right rear speed sensor • Speed sensor rotor
C1239 / 39 (DI-79)	Foreign matter is attached on the tip of the left rear sensor	<ul style="list-style-type: none"> • Left rear speed sensor • Speed sensor rotor
C1241 / 41 ★	Low battery voltage or abnormally high battery voltage	<ul style="list-style-type: none"> • Battery • IC regulator • Power source circuit
C1242 / 42* ² ★	Open circuit in IG2 circuit	<ul style="list-style-type: none"> • Battery • IC regulator • Power source circuit
C1243 / 43 ★	Malfunction in deceleration sensor (constant output)	<ul style="list-style-type: none"> • Deceleration sensor • Wire harness for deceleration sensor system
C1244 / 44 ★	Open or short circuit in deceleration sensor circuit	<ul style="list-style-type: none"> • Deceleration sensor • Deceleration sensor circuit
C1245 / 45 ★	Malfunction in deceleration sensor	<ul style="list-style-type: none"> • Deceleration sensor • Wire harness for deceleration sensor system
C1246 / 46 ★	Malfunction in master cylinder pressure sensor	<ul style="list-style-type: none"> • Master cylinder pressure sensor • Master cylinder pressure sensor circuit
C1249 / 49 ★	Open circuit in stop light switch circuit	Stop light switch circuit
C1251 / 51* ² ★	Pump motor is locked Open circuit in pump motor ground	Hydraulic brake booster pump motor
C1252 / 52* ² ★	Hydraulic brake booster pump motor malfunction	<ul style="list-style-type: none"> • Hydraulic brake booster pump motor • Hydraulic brake booster pump motor circuit • Pressure switch (PH or PL)
C1253 / 53* ² ★	Hydraulic brake booster pump motor relay malfunction	<ul style="list-style-type: none"> • ABS motor 1 or ABS motor 2 relay • ABS motor 1 or ABS motor 2 relay circuit • Hydraulic brake booster pump motor circuit
C1254 / 54* ² ★	Pressure switch malfunction	<ul style="list-style-type: none"> • Pressure switch (PH or PL) • Pressure switch circuit
C1256 / 56* ² ★	Accumulator low pressure malfunction	<ul style="list-style-type: none"> • Accumulator • Pressure switch (PH or PL) • Hydraulic brake booster pump motor
C1257 / 57* ² ★	Power supply drive circuit malfunction	<ul style="list-style-type: none"> • Battery • Power source circuit • Skid control ECU
C1203 / 59 ★	Engine and ECT ECU communication circuit malfunction	<ul style="list-style-type: none"> • TRC+ or TRC- circuit • ENG+ or ENG- circuit • Engine and ECT ECU
C1268 / 68 ★	Transfer L4 position signal transmission failure	<ul style="list-style-type: none"> • Transfer L4 position switch • Transfer L4 position switch circuit
Always ON ★	Malfunction in skid control ECU	<ul style="list-style-type: none"> • Battery • IC regulator • Power source circuit • Skid control ECU

*1: As the DTC cannot be erased by replacing parts alone do either of the following operations.

Clear the DTC (see Pub. No. RM970E, page DI-185).

At a vehicle speed of 20 km/h (12 mph), drive the vehicle for 30 seconds or more.

★: Refer to LAND CRUISER Repair Manual Pub. No. RM970E

*2: Using the following table, troubled parts can be specified.

DTC		42		51		52		53		54		56		57	
BRAKE warning light and buzzer		Light	Buzzer	Light	Buzzer	Light	Buzzer	Light	Buzzer	Light	Buzzer	Light	Buzzer	Light	Buzzer
Pressure switch	PH					○	○			○		○	○		
	PL					○	○			○		○	○		
Pump motor circuit	Pump motor			○	○	○	○					○	○		
	MTT wire harness					○	○	○							
	MT+ wire harness			○											
	MT- wire harness			○											
Accumulator malfunction												○	○		
Motor relay circuit	MR1 open circuit							○							
	MR2 open circuit							○							
	MR1 welded contact					○	○	○							
	MR2 welded contact					○	○	○							
Hydraulic brake booster	Pressure leaks					○	○					○	○		
Power source*	IG2 open circuit	○													
ECU	Power supply circuit													○	

*: When IG1 circuit is open, the ABS warning light and BRAKE warning light come on.

DTC chart of VSC:

DTC No. (See Page)	Detection Item	Trouble Area
C1231 / 31 ★	Malfunction in steering angle sensor	<ul style="list-style-type: none"> • Steering angle sensor • Steering angle sensor circuit
C1232 / 32 ★	Malfunction in deceleration sensor	<ul style="list-style-type: none"> • Deceleration sensor • Deceleration sensor circuit
C1233 / 33 ★	Open or short circuit in yaw rate sensor circuit	<ul style="list-style-type: none"> • Yaw rate sensor • Yaw rate sensor circuit
C1234 / 34 ★	Malfunction in yaw rate sensor	<ul style="list-style-type: none"> • Yaw rate sensor • Yaw rate sensor circuit
C1335 / 35 ★	Malfunction in steering angle sensor communication circuit	<ul style="list-style-type: none"> • Steering angle sensor • Steering angle sensor circuit
C1210 / 36 ★	Zero point calibration of yaw rate sensor undone	<ul style="list-style-type: none"> • Yaw rate sensor • Yaw rate sensor circuit • Neutral start switch circuit (P range)
C1336 / 39 ★	Zero point calibration of deceleration sensor	<ul style="list-style-type: none"> • Deceleration sensor • Deceleration sensor circuit • Neutral start switch (P range) circuit
C1289 / 41* ★	Malfunction in VGRS control system	VGRS control system
C1223 / 43 ★	Malfunction in ABS control system	ABS control system
C1224 / 44 ★	Open or short circuit in NE signal circuit	<ul style="list-style-type: none"> • NEO circuit • Engine and ECT ECU • Skid control ECU
C1340 / 47 ★	Open circuit in center differential lock signal	<ul style="list-style-type: none"> • Center differential lock system • Center differential lock circuit
C1291 / 48* ★	VGRS ECU communication circuit malfunction	<ul style="list-style-type: none"> • VSC+ or VSC- circuit • AFS+ or AFS- circuit • Engine and ECT ECU
C1201 / 51 ★	Engine and ECT ECU system malfunction	Engine control system
C1203 / 53 ★	Engine and ECT ECU communication circuit malfunction	<ul style="list-style-type: none"> • TRC+ or TRC- circuit • ENG+ or ENG- circuit • Engine and ECT ECU
C1290 / 66 (DI-87)	Zero point calibration of steering sensor undone	<ul style="list-style-type: none"> • Steering angle sensor zero point calibration undone • Yaw rate sensor zero point calibration undone
Always ON ★	Malfunction in skid control ECU Open circuit in VSC TRC warning light circuit	<ul style="list-style-type: none"> • Power source circuit • VSC TRC warning light circuit

*: w/ VGRS only

HINT:

There is a case that hand-held tester cannot be used when the VSC TRC warning light is always on.

★:Refer to LAND CRUISER Repair Manual Pub. No. RM970E.

CIRCUIT INSPECTION

DTC	C0200 / 31 - C1239 / 39	Speed Sensor Circuit
------------	--------------------------------	-----------------------------

CIRCUIT DESCRIPTION

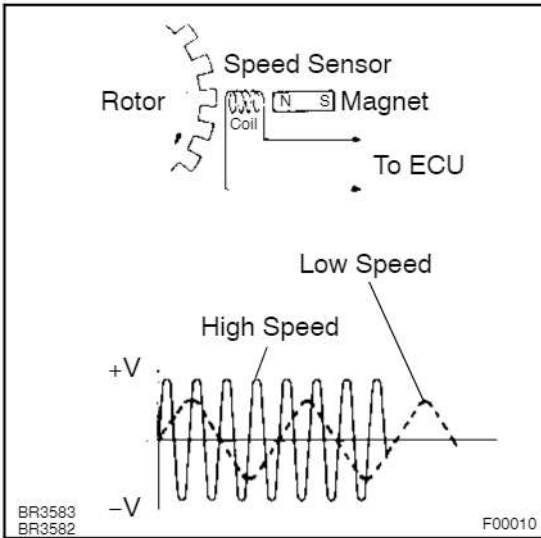

The speed sensor detects wheel speed and sends the appropriate signals to the ECU. These signals are used for control of both the ABS & BA & VSC control system. The front and rear rotors each have 48 serrations.

When the rotors rotate, the magnetic field emitted by the permanent magnet in the speed sensor generates AC voltage. Since the frequency of this AC voltage changes in direct proportion to the speed of the rotor, the frequency is used by the ECU to detect the speed of each wheel.

DTC No.	DTC Detecting Condition	Trouble Area
C0200 / 31 C0205 / 32 C0210 / 33 C0215 / 34	<p>Detection of any of the conditions 1. through 4.:</p> <ol style="list-style-type: none"> At a vehicle speed of 10 km/h (6 mph) or more, pulses are not input for 15 sec. Momentary interruption of the speed sensor signal occurs at least 7 times in the time between switching the ignition switch ON and switching it OFF. Continuous noise occurs into the speed sensor signals with a vehicle speed at 20 km/h (12 mph) or more. The condition that the speed sensor signal circuit is open continues for 0.12 sec. or more. <ul style="list-style-type: none"> •ABS does not function •Brake pedal is not depressed •Parking brake is not set •Rear differential does not lock <p>Under the above conditions, when the difference in velocity between the highest rotating and the second highest rotating wheels is within 2 km/h (1.2 mph), the slowest wheel rotates at 0 km/h (0 mph), and the second slowest wheel rotates at 12 km/h (7.5 mph) for 1 second or more.</p>	<ul style="list-style-type: none"> • Right front, left front, right rear and left rear speed sensor • Each speed sensor circuit • Sensor rotor
C1235 / 35 C1236 / 36 C1238 / 38 C1239 / 39	<p>Continuous noise occurs into the speed sensor signals with the vehicle speed at 20 km/h (12 mph) or more continues for 5 sec or more.</p>	<ul style="list-style-type: none"> • Right front, left front, right rear, left rear speed sensor • Speed sensor rotor

HINT:

- DTC No. C0200 / 31 and C1235 / 35 are for the right front speed sensor.
- DTC No. C0205 / 32 and C1236 / 36 are for the left front speed sensor.
- DTC No. C0210 / 33 and C1238 / 38 are for the right rear speed sensor.
- DTC No. C0215 / 34 and C1239 / 39 are for the left rear speed sensor.

WIRING DIAGRAM

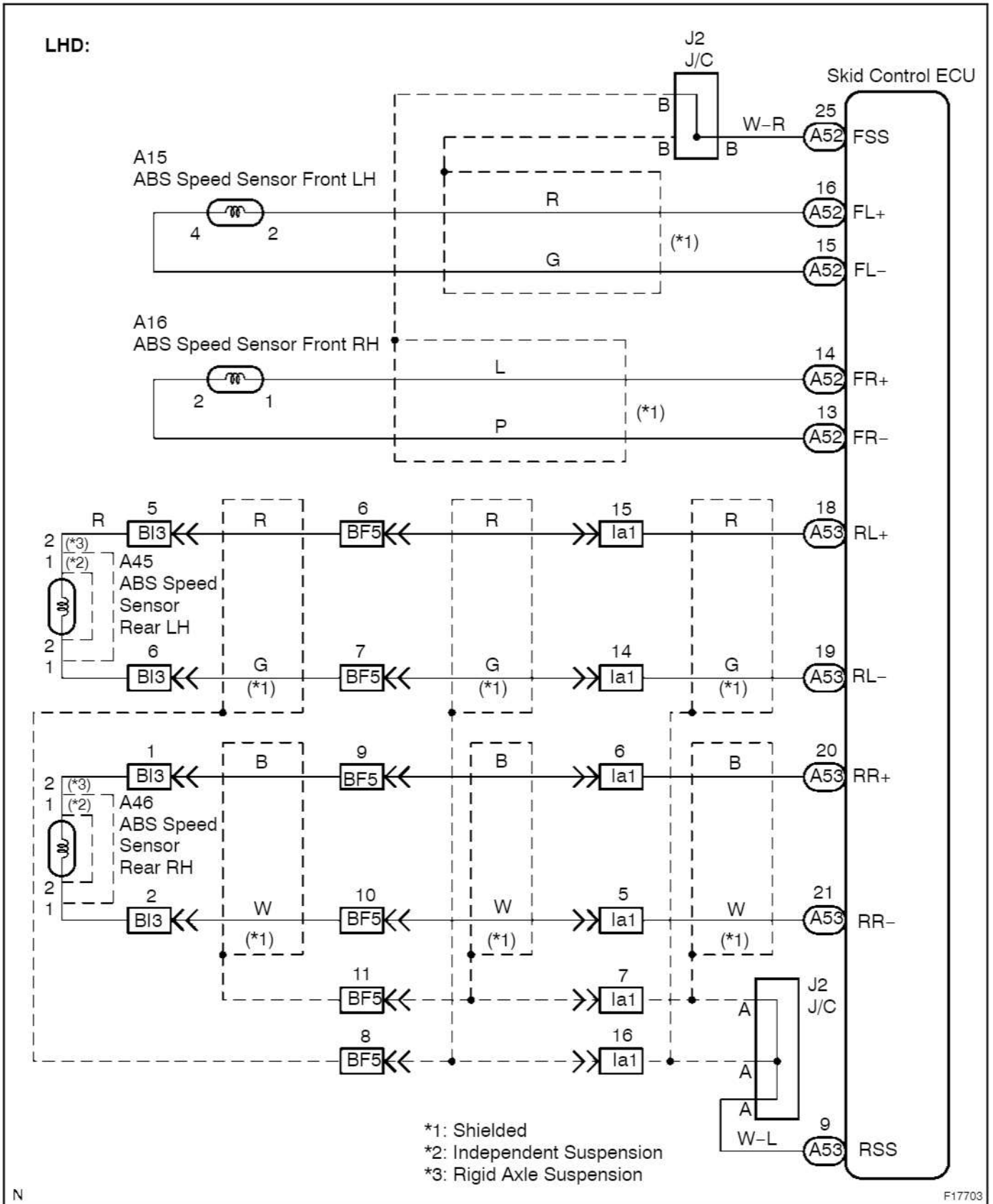

cardiagn.com

RHD:

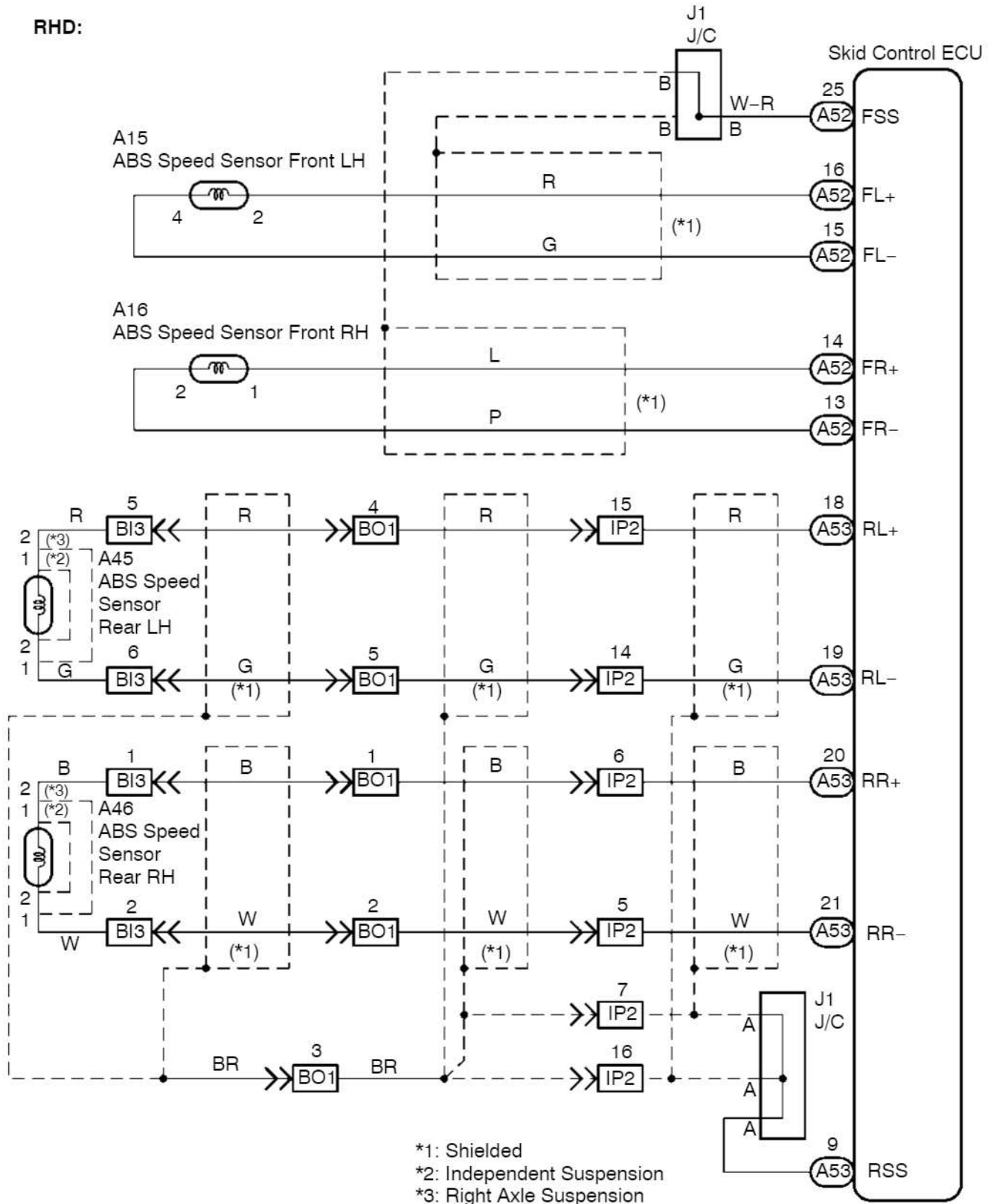

N

F17704

INSPECTION PROCEDURE**HINT:**

Start the inspection from step 1 in case of using the hand-held tester and start from step 2 in case of not using the hand-held tester.

1	Check output value of speed sensor.
----------	--

PREPARATION:

- (a) Connect the hand-held tester to the DLC3.
- (b) Turn the ignition switch to the ON position and push the hand-held tester main switch ON.
- (c) Select the DATA LIST mode on the hand-held tester.

CHECK:

Check that there is no difference between the speed value output from the speed sensor displayed on the hand-held tester and the speed value displayed on the speedometer when driving the vehicle.

OK:

There is almost no difference from the displayed speed value.

HINT:

There is tolerance of $\pm 10\%$ in the speedometer indication.

OK

Check and replace skid control ECU.

NG

2	Check speed sensor.
----------	----------------------------

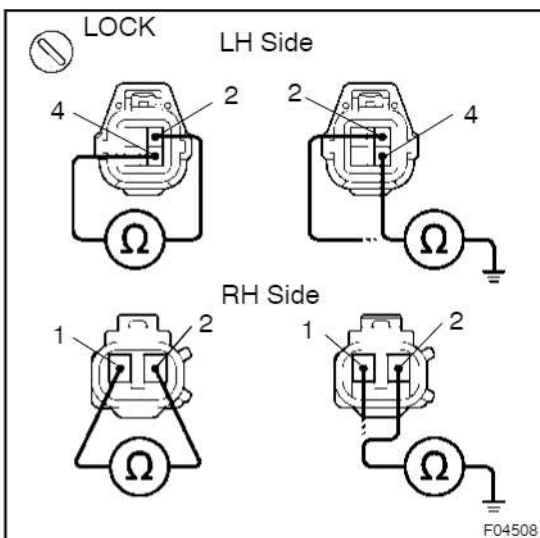
**Front:****PREPARATION:**

- (a) Make sure that there is no looseness at the connector's locking part and connecting part of the connector.
- (b) Disconnect the speed sensor connector.

CHECK:

- LH side:
Measure resistance between terminals 2 and 4 of the speed sensor connector.
- RH side:
Measure resistance between terminals 1 and 2 of the speed sensor connector.

OK:

Resistance: 0.92 to 1.22 k Ω

CHECK:

- LH side:
Measure resistance between terminals 2 and 4 of the speed sensor connector and body ground.
- RH side:
Measure resistance between terminals 1 and 2 of the speed sensor connector and body ground.

OK:

Resistance: 10 kΩ or higher

Rear:

PREPARATION:

- Make sure that there is no looseness at the connector locking part and connecting part of the connector.
- Disconnect the speed sensor connector.

CHECK:

Measure resistance between terminals 1 and 2 of the speed sensor connector.

OK:

Resistance: 1.0 to 1.4 kΩ

CHECK:

Measure resistance between terminal 1 or 2 of the speed sensor connector and body ground.

OK:

Resistance: 10 kΩ or higher

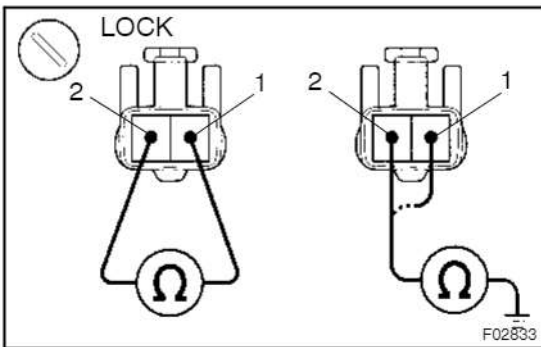

NG	Replace speed sensor.
-----------	------------------------------

NOTICE:

Check the speed sensor signal after replacement (see Pub. No. RM970E, page DI-185)

OK

3	Check for open and short circuit in harness and connector between each speed sensor and ECU (See page IN-38).
----------	--

NG	Repair or replace harness or connector.
-----------	--

OK

4	Check sensor installation.
----------	-----------------------------------

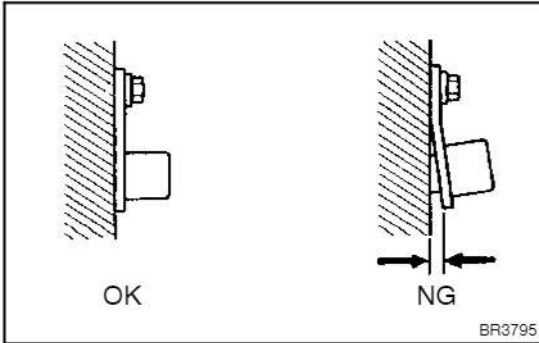
**CHECK:**

Check the speed sensor installation.

OK:

The installation bolt is tightened properly and there is no clearance between the sensor and front steering knuckle or rear axle shaft.

NG	Replace speed sensor.
-----------	------------------------------

NOTICE:

Check the speed sensor signal after replacement (see Pub. No. RM970E, page DI-185)

OK

5 Check speed sensor and sensor rotor serrations.

(REFERENCE) INSPECTION USING OSCILLOSCOPE

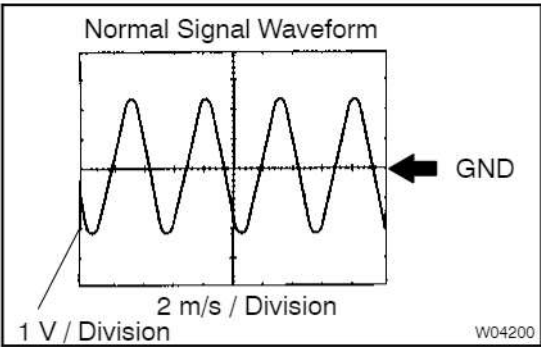

PREPARATION:

- (a) Remove the skid control ECU.
- (b) Connect the oscilloscope to the each of terminals FR+, FL+, RR+ or RL+ and GND of the skid control ECU.

CHECK:

Drive the vehicle at about 20 km/h (12 mph), and check the signal waveform.

OK:

A waveform as shown in a figure should be output.

HINT:

- As the vehicle speed (wheel revolution speed) increases, a cycle of waveform narrows and the fluctuation in output voltage becomes greater.
- When noise is identified in the waveform on the oscilloscope, error signals are generated due to the speed sensor rotors scratches, looseness or foreign matter on it.

OK → **Check and replace skid control ECU.**

NG

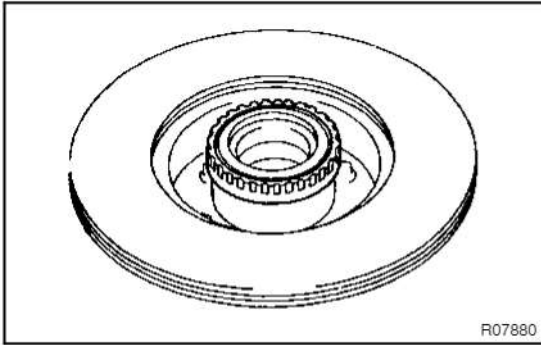
6 Check sensor rotor and sensor tip.**Front:****PREPARATION:**

Remove the front axle hub (see Pub No. RM616E, page SA-21).

CHECK:

Check the sensor rotor serrations.

OK:

No scratches, missing teeth or foreign matter.

PREPARATION:

Remove the front speed sensor (see Pub No. RM616E, page BR-89).

CHECK:

Check the sensor tip.

OK:

No scratches or foreign matter on the sensor tip.

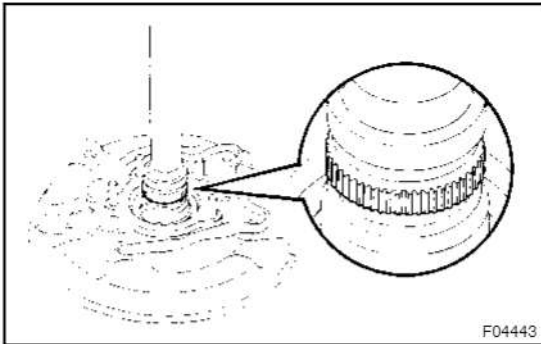
**Rear:****PREPARATION:**

Remove the rear axle shaft (see Pub No. RM616E, page SA-161).

CHECK:

Check the sensor rotor serrations.

OK:

No scratches, missing teeth or foreign matter.

PREPARATION:

Remove the rear speed sensor (see Pub No. RM616E, page BR-92).

CHECK:

Check the sensor tip.

OK:

No scratches or foreign matter on the sensor tip.

NG**Replace speed sensor or rotor.****NOTICE:**

Check the speed sensor signal after replacement (see Pub. No. RM970E, page DI-185)

OK**Check and replace skid control ECU.**

DTC	C1290 / 66	Zero Point Calibration of Steering Sensor Undone
------------	-------------------	---

CIRCUIT DESCRIPTION

DTC No.	DTC Detecting Condition	Trouble Area
C1290 / 66	The steering sensor zero point calibration position vastly differs from the recorded value. (The angle becomes larger)	<ul style="list-style-type: none"> • Yaw rate sensor zero point calibration undone • Steering angle sensor zero point calibration undone

INSPECTION PROCEDURE

1	Perform zero point calibration. (LAND CRUISER Repair Manual Pub. No. RM970E)
----------	---

HINT:

This code is output when a problem occurs at the zero point calibration of the steering angle sensor and yaw rate sensor.

Therefore, clear the stored zero point calibration data and correct the zero points.

- (a) Clear the zero point calibration data.
- (b) Perform a zero point calibration of the steering sensor and yaw rate sensor.

NEXT

2	Is DTC output?
----------	-----------------------

- (a) Clear the DTCs.
- (b) Turn the ignition switch to the ON position.
- (c) Are the same DTCs detected?

NO → **Proceed to next circuit inspection shown on problem symptoms table.**

YES

No problem.

HINT:

When the registered data is not equal to the input data, the DTC will be output.

VARIABLE GEAR RATIO STEERING

HOW TO PROCEED WITH TROUBLESHOOTING

Troubleshooting in accordance with the procedure on the following pages.

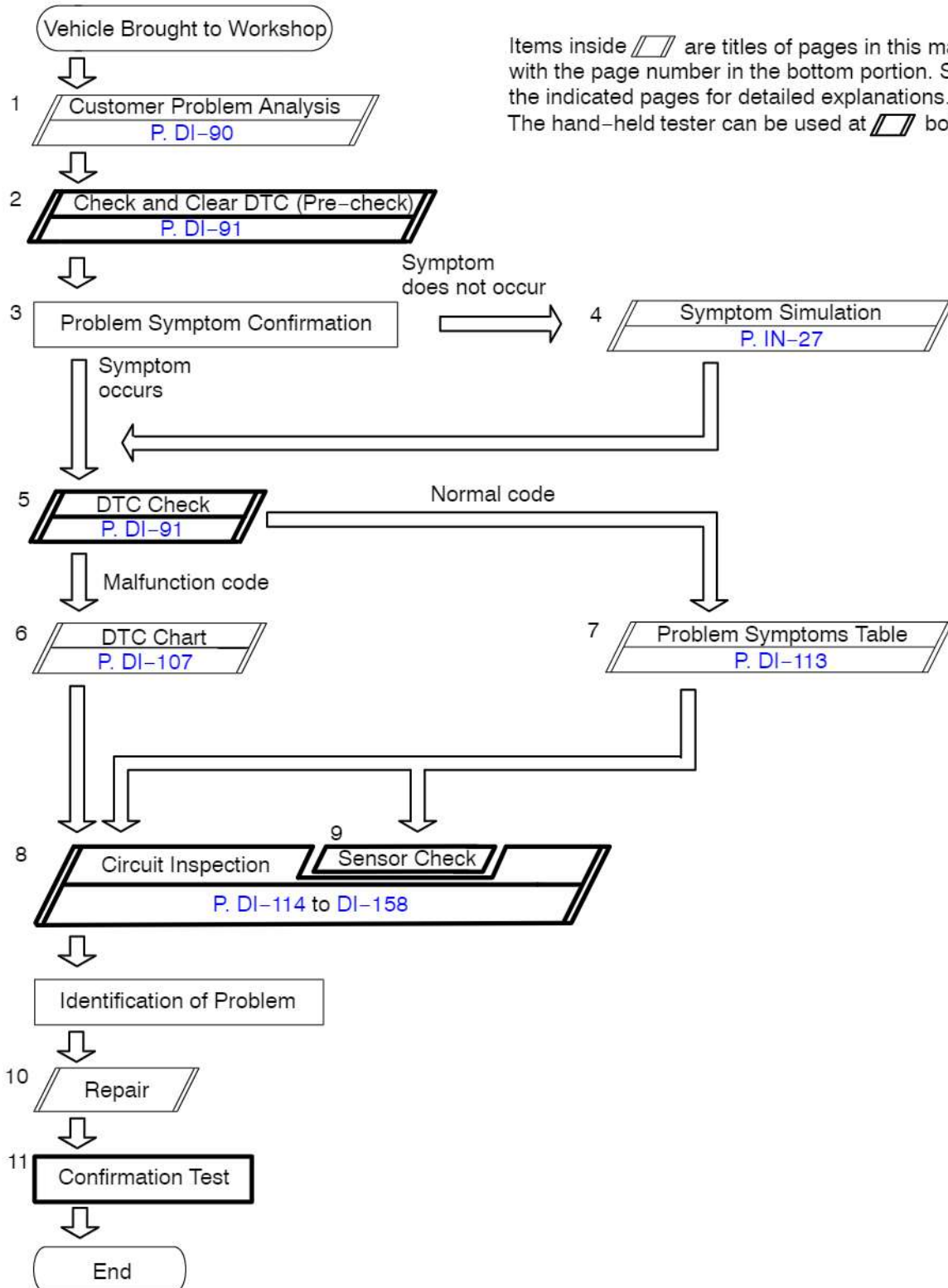

PRECAUTION

CAUTION:

1. After replacing VGRS ECU or VGRS actuator or repairing steering system parts, proceed with the following operations in the order listed.
 - (a) Perform VGRS system calibration
 - (b) Perform VGRS system initialization by driving vehicle
 - (c) Confirm steering angle flag is VALID
 - (d) Test drive vehicle to confirm steering is centered
2. When the steering wheel is still off-center after completing the steering angle sensor initialization, perform the VGRS system calibration ([See page DI-100](#)).
3. When each of the following procedures is completed, be sure to perform the steering angle initialization.
 - Reconnect the battery terminal
 - Replace the battery
 - Reconnect the connectors (steering angle sensor, VGRS ECU, VGRS actuator, skid control ECU)
4. The inspection of the VGRS system may detect the DTC in the VSC and AHC system. After the inspection of the VGRS system, check the DTC in the VSC and AHC system and clear the DTC.
5. Conditions for the VGRS system suspension
 - (a) When the power supply voltage is too low or too high.
 - (b) When protecting the VGRS system from heat. (The system is suspended to prevent the VGRS actuator motor or ECU from heating up. The system returns to a normal condition when the temperature of the VGRS actuator motor returns to the operating range.)
 - (c) When the temperature is extremely low. (When the temperature is approx. -30°C , the system control will be suspended.)

CUSTOMER PROBLEM ANALYSIS CHECK

VGRS Check Sheet

 Inspector's
Name : _____

Customer's Name		VIN	
		Production Date	/ /
		Licence No.	
Date Vehicle Brought In	/ /	Odometer Reading	km miles

Date Problem First Occurred	/ /
Frequency Problem Occurs	<input type="checkbox"/> Continuous <input type="checkbox"/> Intermittent (times a day)

Symptoms	<input type="checkbox"/> Steering wheel off-center.	
	<input type="checkbox"/> VGRS stops and does not operate.	
	<input type="checkbox"/> Steering angle is different from right to left.	
	<input type="checkbox"/> Abnormal noise and vibration is produced in the steering wheel	
	VGRS Warning Light Abnormal	<input type="checkbox"/> Remains ON <input type="checkbox"/> Does not Light Up

DTC Check	1st Time	<input type="checkbox"/> Normal Code <input type="checkbox"/> Malfunction Code (Code)
	2nd Time	<input type="checkbox"/> Normal Code <input type="checkbox"/> Malfunction Code (Code)

Just before the VGRS warning light comes on, was the engine stalled or the battery terminal removed?	<input type="checkbox"/> YES <input type="checkbox"/> NO
Within the past month, have any parts relating to VGRS been replaced?	<input type="checkbox"/> YES <input type="checkbox"/> NO

PRE-CHECK

1. VGRS SYSTEM DESCRIPTION

The VGRS (Variable Gear Ratio Steering) system controls the steering angle in accordance with the vehicle speed. The system is controlled by the VGRS ECU which operates the VGRS actuator mounted on the steering intermediate shaft. The operating angle of the actuator is added to the steering angle of the intermediate shaft in order to vary the turning angle of the front wheels in accordance with the vehicle speed.

When the VGRS system is operating normally, the steering wheel can be turned approximately 2.4 turns from lock to lock, with the engine running and the vehicle stopped.

When the system detects a fault, the VGRS ECU illuminates the VGRS warning light to inform the driver that the system is not operating.

CAUTION:

There may be conditions that will cause the steering wheel to be off center.

Refer to [page DI-99](#) for further details.

2. DIAGNOSIS SYSTEM

- (a) Inspect the battery voltage.

Battery voltage: 11 to 14 V

If voltage is below 11 V, recharge the battery before proceeding.

- (b) Check the warning light.

With the ignition switch ON, the light should illuminate for 2 seconds and then go out. If the light remains on after 2 seconds, check for DTCs.

HINT:

If the light does not illuminate, proceed to troubleshooting for the VGRS warning light circuit ([See page DI-167](#)).

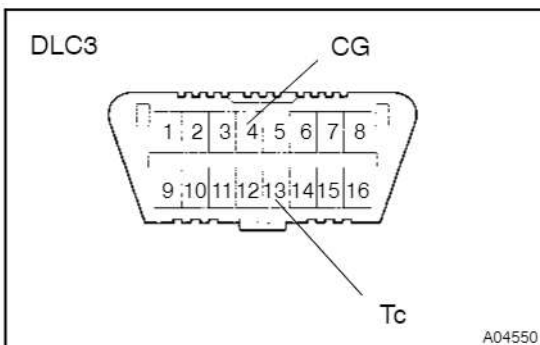

3. DTC CHECK (USING SST CHECK WIRE)

- (a) Checking DTCs using a SST check wire.

SST 09843-18040

- (1) Using the SST, connect terminals Tc and CG of DLC3.
- (2) Turn the ignition switch ON.

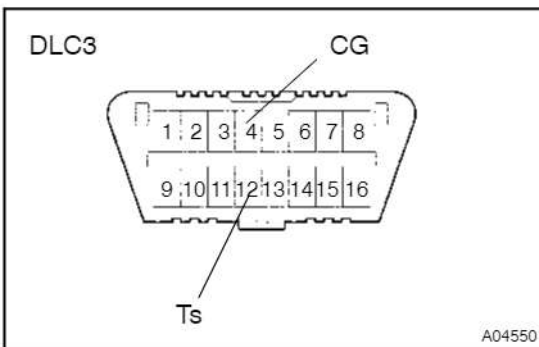
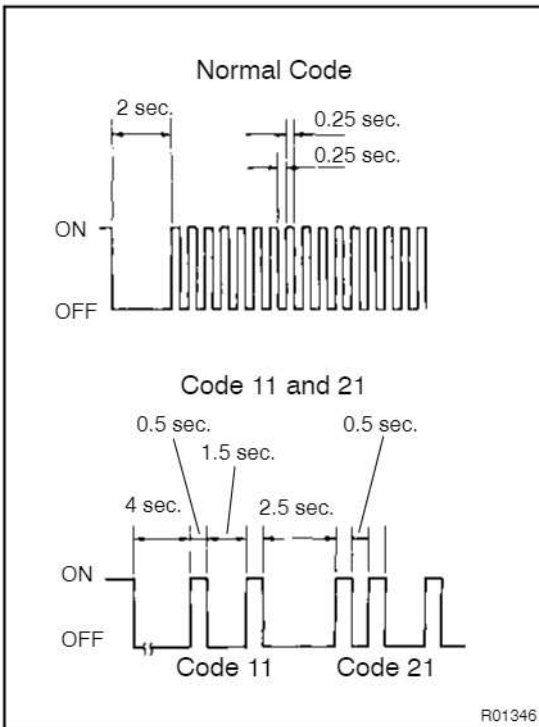

- (3) Read and record any DTCs from the VGRS warning light on the combination meter. Refer to the chart on the left for examples of a normal code and codes 11 and 21.

HINT:

If the VGRS warning light does not blink any DTC codes or the normal code, inspect the warning light circuit.

Trouble Area	See page
Tc and CG terminal circuit	DI-169
VGRS warning light circuit	DI-167

- (4) Refer to the Diagnostic Trouble Code Chart (See page DI-107) for DTC information.

- (b) Clearing the DTCs using the SST check wire.

- (1) Turn the ignition switch ON.
 - (2) Using the SST, connect terminals Ts and CG of DLC3.
- SST 09843-18040
- (3) Disconnect and connect the SST check wire from the CG terminal 4 times or more in 8 seconds.
 - (4) Check that the VGRS warning light blinks a normal code.

HINT:

If the fault has not been repaired, the code may still be displayed.

- (5) Turn the ignition switch OFF.
- (6) Remove the SST check wire from DLC3.
- (7) Perform the zero point calibration for the deceleration sensor and yaw rate sensor (See Pub. No. RM970E, page DI-185).

HINT:

When clearing the VGRS codes, the deceleration sensor and yaw rate sensor memory is also cleared. Therefore it is necessary to complete the zero point calibration (See Pub. No. RM970E, page DI-185).

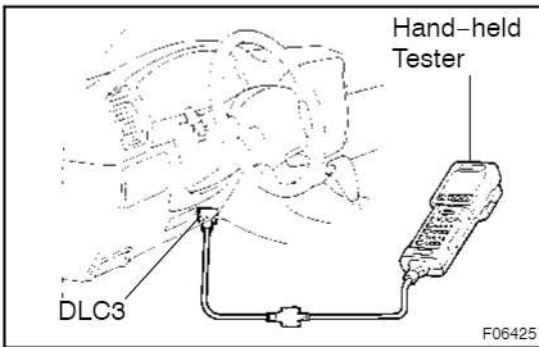

4. DTC CHECK (USING HAND-HELD TESTER)

- (a) Checking DTCs using the Hand-held tester.
- (1) Connect the hand-held tester to DLC3.
 - (2) Turn the ignition switch ON.
 - (3) Read the DTCs following the prompts on the tester screen.

HINT:

Refer to the hand-held tester operator's manual for further details.

- (b) Clearing the DTCs using the hand-held tester.
- (1) Connect the hand-held tester to DLC3.
 - (2) Turn the ignition switch ON.
 - (3) Erase the DTCs following the prompts on the tester screen.

HINT:

Refer to the hand-held tester operator's manual for further details.

5. DATA LIST

With the hand-held tester connected to DLC3 and the ignition turned ON, the VGRS data list can be displayed. Follow the prompts on the tester screen to access the Data List.

Item	Measurement Item / Range (Display)	Normal Condition	Diagnostic Note
STEERING POS1	Steering sensor 1 reading / min.: -1862 deg, 1877deg	-1682 to 1877 deg	Turn the steering wheel changes the value
STEERING POS2	Steering sensor 2 reading / min.: -1862 deg, 1877deg	-1682 to 1877 deg	Turn the steering wheel changes the value
STR SENS1	Steering sensor 1 / HIGH or LOW	High or Low	Turn the steering wheel switches high or low
STR SENS2	Steering sensor 2 / HIGH or LOW	High or Low	Turn the steering wheel switches high or low
STR SENS3	Steering sensor 3 / HIGH or LOW	High or Low	Turn the steering wheel switches high or low
SPD (VSC)	Speed sensor reading / min.: 0 km/h, max.: 255 km/h	Actual vehicle speed	Speed indicated on speedometer
WHEEL SPD RR	Wheel speed sensor (RR) reading / min.: 0 km/h, max.: 255 km/h	Actual vehicle speed	Speed indicated on speedometer
WHEEL SPD RL	Wheel speed sensor (RL) reading / min.: 0 km/h, max.: 255 km/h	Actual vehicle speed	Speed indicated on speedometer
ENGINE REV (RPM)	Revolution sensor / LESS 300 or MORE 300	Less than 300	Engine stop
		More than 300	Engine running
MTR SOU CUR	Motor power source actual current / min.: 0 A, max.: 127.5 A	Less than 10 A	When not turning the steering wheel
		Less than 60 A	When turning the steering wheel
MTR SOU CUR EST	Estimated motor power source actual current / min.: 0 A, max.: 127.5 A	Less than 10 A	When not turning the steering wheel
		Less than 60 A	When turning the steering wheel
PIG SOURCE VOL	PIG source voltage / min.: 0 V, max.: 22.5 V	9 to 16 V	IG switch ON (Engine stop)
IG SOURCE VOL	IG source voltage / min.: 0 V, max.: 22.5 V	9 to 16 V	IG switch ON (Engine stop)

MTR CUR EST	Motor estimation current / min.: 0 A, max.: 127.5 V	Less than 10 A	When not turning the steering wheel
		Less than 60 A	When turning the steering wheel
TERMINAL VOL U	Terminal voltage U / min.: 0 V, max.: 25.5 V	0 to 16 V	Turn the steering wheel changes the value (When the engine running and VGRS system operates)
TERMINAL VOL V	Terminal voltage V / min.: 0 V, max.: 25.5 V	0 to 16 V	Turn the steering wheel changes the value (When the engine running and VGRS system operates)
TERMINAL VOL W	Terminal voltage W / min.: 0 V, max.: 25.5 V	0 to 16 V	Turn the steering wheel changes the value (When the engine running and VGRS system operates)
ACTUATOR POS	Actuator position / min.: -286 deg, max.: 288 deg	-286 to 288 deg	Turn the steering wheel changes the value (When the engine running and VGRS warning light goes off)
MTR REV ANG U	Motor revolution angle sensor output U HIGH or LOW	High or Low	Turn the steering wheel changes the value (When the engine running and VGRS warning light goes off)
MTR REV ANG V	Motor revolution angle sensor output V HIGH or LOW	High or Low	Turn the steering wheel changes the value (When the engine running and VGRS warning light goes off)
MTR REV ANG W	Motor revolution angle sensor output W HIGH or LOW	High or Low	Turn the steering wheel changes the value (When the engine running and VGRS warning light goes off)
STR ANG VEL	Steering wheel angle velocity / min.: -1862 deg, max.: 1877 deg / sec.	-1862 to 1877 deg / sec.	Turn the steering wheel changes the value (When the engine running and VGRS warning light goes off)
LOCK OUTPUT VOL	Lock motor output voltage / min.: 0 V, max.: 22.5V	9 to 16 V	IG switch ON (Engine stop)
THERMISTOR TEMP	Thermistor temperature / min.: -50 °C, max.: 205 °C	-50 to 205 °C	When the VGRS system operates
ACT TARGET ANGL	Actuator target angle / min.: -286 deg, max.: 288 deg	-286 to 288 deg	When the VGRS system operates
ACT REV SPD	Actuator revolution speed / min.: -1862 deg, max.: 1877 deg / sec.	-1862 to 1877 deg / sec.	When the VGRS system operates
DUTY VAL	Command value DUTY / min.: 0 %, max.: 100 %	0 to 100%	When the VGRS system operates
LOCK DUTY VAL	Command value DUTY for actuator lock control / min.: 0 %, max.: 100 %	Less than 10%	IG switch ON
STRAIGHT ANG FLG *1	Straight steering angle valid flag / INVALID or VALID	VALID or INVALID	Immediately after connecting the battery terminal
ACT DEV ANGL	Actuator deviation angle / min.: -286 deg, max.: 288 deg	-286 to 288 deg	When the VGRS system operates

ACT TEMP EST	Actuator estimation temperature / min.: -50 °C, max.: 205 °C	-50 to 205 °C	When the VGRS system operates
MTR OVERHEAT *2	Record of continuous overheat preventive control / Rec or Unrec	Rec or Unrec	-
MTR LOW POWER *2	Record of low motor power source voltage / Rec or Unrec	Rec or Unrec	-
MTR HIGH POWER *2	Record of high motor power source voltage / Rec or Unrec	Rec or Unrec	-
FLO MALFUNCTION *2	Record of wheel speed malfunction (left) / Rec or Unrec	Rec or Unrec	-
FRO MALFUNCTION *2	Record of wheel speed malfunction (right) / Rec or Unrec	Rec or Unrec	-
TEST MODE	Test mode / NORMAL or TEST	NORMAL : Normal mode TEST : During test mode	-
#CODES	Number of DTC recorded / min.: 0, max.: 255	Min.: 0, max.: 39	-

***1: NOTICE:**

This data must read valid before proceeding with any steering adjustments. If invalid, perform steering angle sensor initialization procedure, or if VGRS actuator or VGRS ECU has been replaced, perform VGRS system calibration (steering angle adjust).

***2: HINT:**

When Rec is listed, reset to Unrec by going to the VGRS menu on the hand-held tester, select records clearance, and follow the prompts.

6. FREEZE FRAME DATA

The VGRS ECU stores memorized data when a trouble code is set and can be viewed using the hand-held tester.

Hand-held tester display	Measurement Item	Value
STEERING POS 1	Steering position 1 (parallel)	-1862 to 1877
SPD (VSC)	Vehicle speed (VSC ECU)	Speed indicated on speedometer
ENGINE REV (RPM)	Engine revolution	Less than 300 or More than 300
MTR SOURCE CUR	Motor power source actual current	0 to 127.5
MTR SOU CUR EST	The estimated motor current	0 to 127.5
PIG SOURCE VOL	PIG-power source voltage	0 to 22.5
IG SOURCE VOL	IG-power source voltage	0 to 22.5
ACTUATOR POS	Actuator position	-286 to 288
STR ANGLE VEL	Steering wheel angle velocity	-1862 to 1877
LOCK OUTPUT VOL	Lock motor output voltage	0 to 22.5
ACT TARGET ANGLE	Actuator target angle	-286 to 288
ACT REV SPD	Actuator revolution speed	-1862 to 1877
DUTY VAL	Command value DUTY	0 to 100
LOCK DUTY VAL	Command value DUTY for actuator lock control	0 to 100

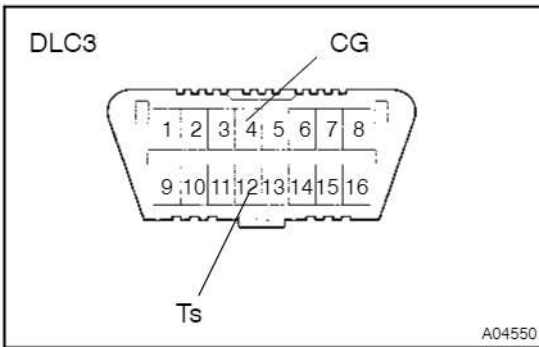

7. VGRS SENSOR SIGNAL CHECK (TEST MODE)

HINT:

- Before entering Test Mode, check and repair any current VGRS DTCs.
 - When entering test mode, the 4 sensor check DTCs are recorded at once. When the ECU judges the sensor normal during the test procedure, the DTC will be eliminated.
- (a) Procedure for Sensor Test Mode using a SST check wire. SST 09843-18040
- (1) Make sure the ignition switch is OFF.
 - (2) Using the SST check wire, connect terminals Ts and CG of DLC3.
 - (3) Turn the ignition switch ON.

- (4) Check that the VGRS warning light is blinking.

HINT:

If the VGRS warning light does not blink, inspect the warning light or Ts terminal circuits.

Trouble Area	See page
Ts and CG terminal circuit	DI-171
VGRS warning light circuit	DI-167

- (5) Start the engine.
- (6) Turn the steering wheel lock to lock.

NOTICE:

- **Check for any unusual feeling in the steering wheel operation.**
- **Slowly turn the steering wheel from lock to lock. check that it rotates approximately 2.4 turns.**

HINT:

- The warning light display has no change.
- If the actuator moving amount is correctly checked, the diagnostic codes C1575/75 and C1576/76 in the test mode are cleared.

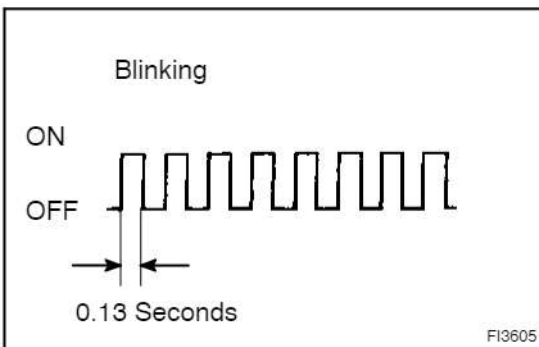

- (7) Drive the vehicle at more than 10 km/h (6 mph) for 15 to 30 seconds.

HINT:

If the vehicle speed sensor is correctly checked, the diagnostic codes C1571/71 and C1572/72 in the test mode are cleared.

HINT: The situation of VGRS warning light when driving.

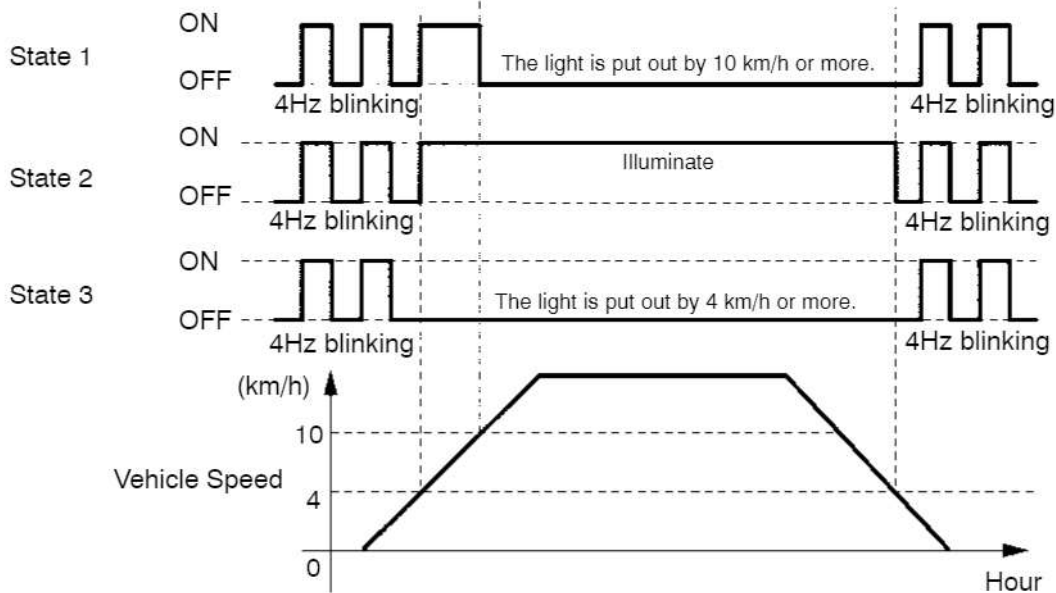

- State 1: If either DTC C1575/75 or C1576/76 is abnormal, the warning light remains on between 4 and 10 km/h after first starting.
- State 2: If a speed sensor DTC is detected at 10 km/h or above, the warning light will remain on until vehicle speed is less than 4 km/h.
- State 3: Warning light pattern when all sensors are normal.

G20187

F17862

- (8) Stop the vehicle. Leave the engine running.

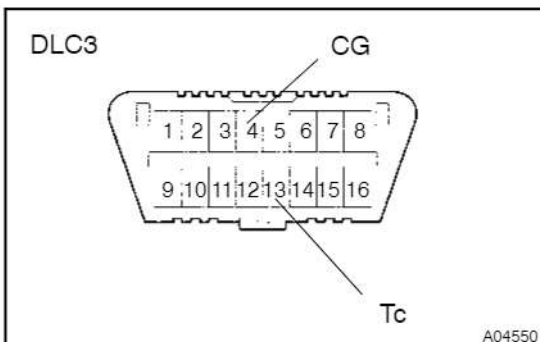

- (9) Using the SST check wire, connect the 3rd terminal of the SST check wire to terminal Tc of DLC3.

SST 09843-18040

- (10) Read the number of blinks of the VGRS warning light. (Refer to the chart below)

HINT:

- If all wheel speed sensors are normal, the normal blinking code is output. (A repeating cycle of 0.25 sec. ON and 0.25 sec. OFF)
- If 2 or more faults are detected at the same time, the lowest number will be displayed first.

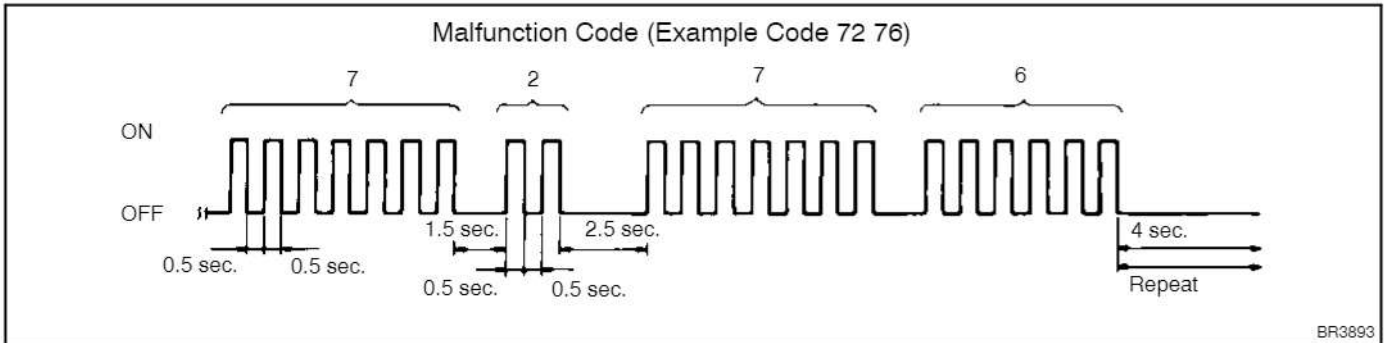

- (11) After completing the check, disconnect the SST from DLC3 and turn the ignition OFF.

- (b) Procedure for Sensor Test Mode using the hand-held tester.

- (1) Connect the hand-held tester.
- (2) Turn the ignition switch ON.
- (3) Complete the VGRS Test Mode following the prompts on the tester screen.

HINT:

Refer to the hand-held tester operator's manual for further details.

- (4) Read the DTCs.
- (5) After completing the test, disconnect the tester and turn the ignition switch OFF.

DTC of VGRS sensor check function:

Code No.	Diagnosis	Trouble Area
C1571 / 71	Vehicle speed sensor malfunction (FLO)	<ul style="list-style-type: none"> • Left front speed sensor • Sensor installation • Sensor rotor
C1572 / 72	Vehicle speed sensor malfunction (FRO)	<ul style="list-style-type: none"> • Right front speed sensor • Sensor installation • Sensor rotor
C1575 / 75	Steering angle sensor malfunction	<ul style="list-style-type: none"> • Steering sensor • Sensor installation
C1576 / 76	DC motor revolution sensor malfunction	<ul style="list-style-type: none"> • VGRS actuator

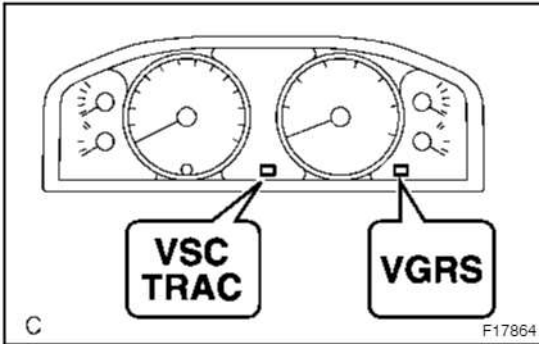

INITIALIZATION

1. STEERING ANGLE SENSOR INITIALIZATION

- (a) Turn the ignition switch to the "ON" position and check that the VGRS and VSC/TRAC warning lights illuminate for a few seconds.

NOTICE:

If the warning lights remain on or blink, repair the applicable system.

- (b) Drive the vehicle on a straight road at 35 km/h (22 mph) or more for 5 seconds or longer. At this point, the steering wheel will still remain off-center by 5 to 10 degrees.

HINT:

In this step, the neutral position of the steering wheel is restored from the VGRS ECU memory.

- (c) After performing normal cornering 2 to 3 times, the steering wheel position is automatically corrected.

NOTICE:

If the steering wheel remains off-center after the above procedure, repair the applicable system.

- (d) Confirm the steering angle sensor initialization is completed.

WHEN USING HAND-HELD TESTER:

Use this procedure to center the steering wheel when the STRAIGHT ANG FLG from the VGRS DATA LIST reads VALID.

WHEN NOT USING HAND-HELD TESTER:

- (1) Drive the vehicle on a road at 60 km/h (37 mph) or more for 30 seconds or longer.

HINT:

At this time, if steering angle initialization is not completed, VGRS system is stopped.

- (2) Stop the vehicle. (Engine running)
 (3) Slowly turn the steering wheel from lock to lock.

HINT:

2 seconds or more for 1 turn.

- (4) If it rotates approximately 2.4 turns, the steering angle sensor initialization is completed. If it rotates approximately 3.5 turns, the steering angle sensor initialization is not completed.

CALIBRATION

1. VGRS SYSTEM CALIBRATION PROCEDURE (USING SST CHECK WIRE)

NOTICE:

Use this procedure to center the steering wheel position if:

- VGRS actuator has been replaced
- VGRS ECU has been replaced
- Steering column or gear has been disconnected
- Steering wheel is still off-center after completing the steering angle sensor initialization in step 6.

Actuator angle initialization:

1	Face the tires straight ahead.
----------	---------------------------------------

NOTICE:

Drive the vehicle to confirm steering wheel is centered.



2	Check for DTCs
----------	-----------------------

Is DTC C1515/15 output?

A	DTC C1515/15 is not output
B	DTC C1515/15 is output

B	Go to step 4
----------	---------------------

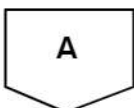

3	Actuator angle initialization
----------	--------------------------------------

NOTICE:

Complete steps (e) to (g) within 1 minute.

- Turn the ignition switch ON.
- Start the engine.
- Turn the steering wheel to the center.
- Using SST check wire, connect the terminals Ts and CG of DLC3.
- Connect and disconnect the SST check wire to the terminal Tc of DLC3 10 times or more within 20 sec.
- Turn the steering wheel to the left 180° or more and then return to the center position.
- Connect and disconnect the SST check wire to the terminal Tc of DLC3 10 times or more within 20 sec.

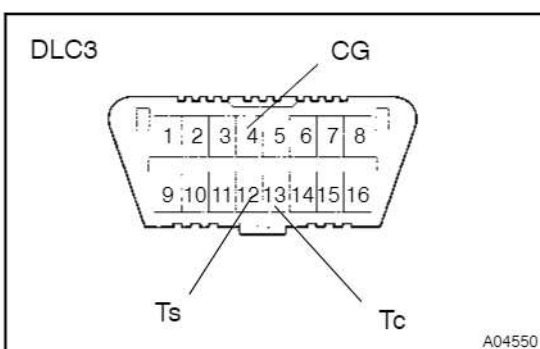

LAND CRUISER (W/G) SUP (RM1072E)

(h) Check that the VGRS warning light is ON.

HINT:

When the VGRS warning light illuminates, DTC 1515/15 is memorized.

- (i) Disconnect the SST check wire from the DLC3.
- (j) Turn the ignition switch OFF.

NEXT

Go to step 1

Steering angle adjustment:

4 Confirm steering center

Confirm that the steering wheel is centered when facing the tires straight ahead.

NOTICE:

Drive the vehicle to confirm steering wheels centered.

A	Steering wheel is off-center
B	Steering wheel is center

B

Go to step 8

A

5 Unlock the VGRS actuator

NOTICE:

Do not start the engine.

- (a) Turn the ignition switch OFF. (Engine stop)
- (b) Disconnect the negative battery terminal.
- (c) Disconnect the VGRS ECU connector "A".
- (d) Connect the jumper wire from terminal MV to Battery (+) and another jumper wire from terminal LG to ground(-).

NOTICE:

Do not apply the voltage for more than 3 minutes.

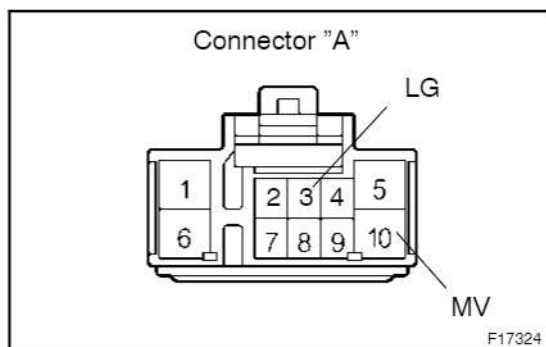

NEXT

LAND CRUISER (W/G) SUP (RM1072E)

6	Steering center adjustment
----------	-----------------------------------

(a) Turn the steering wheel to the center.

NOTICE:

If the spiral cable for the airbag is not centered when installing the steering wheel, adjust the spiral cable to the center (See page SR-17).

NEXT

7	Lock the VGRS actuator
----------	-------------------------------

- (a) Confirm the ignition switch is turned OFF.
 (b) Reconnect the VGRS ECU connector "A".
 (c) Reconnect the battery terminal.
 (d) Turn the steering wheel to the right and left by about 5 degrees and check that the steering wheel is level.

NOTICE:

The DTC will be detected later on when not turning the steering wheel to the right and left by about 5 degrees.

NEXT

Go to step 1

Actuator angle adjustment:

8	Adjust the actuator angle
----------	----------------------------------

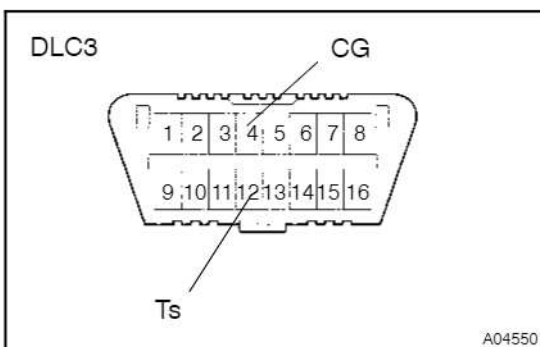
**HINT:**

Actuator angle adjustment is completed by turning the Test Mode ON and OFF.

- (a) Make sure the ignition switch is OFF.
 (b) Using the SST check wire, connect the terminals Ts and CG of DLC3.
 (c) Turn the ignition switch ON.
 (d) Check that the VGRS warning light is blinking.
 (e) Turn the ignition switch OFF and disconnect the SST check wire from the DLC3.
 (f) Actuator angle sensor learning confirmation procedure:
 (1) Start the engine.
 (2) Turn the steering wheel from center to the left 90° and then back to center.
 (3) Turn the steering wheel from center to the right 90° and then back to center.
 (4) Confirm that the steering wheel is centered.

- (5) Hold the steering wheel in the centered position for 3 seconds.
- (6) Perform the following check procedure;
 - Turn the steering wheel slowly to the left.
 - While turning the steering wheel to the left, turn off the engine.
 - Continue to turn the steering wheel slowly to the left for 3 seconds.
- (7) Repeat steps (1) to (6) 15 times.

NOTICE:

DTC C1568/68 requires that the fault occurs 5 consecutive times to set. The confirmation procedure must be performed multiple times to ensure the condition does not repeat.

- (8) Recheck for DTCs
 - If C1568/68 is set, repeat the procedure for a second time. If C1568/68 is set again, replace the VGRS actuator.

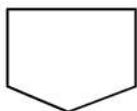

END

2. VGRS SYSTEM CALIBRATION PROCEDURE (USING HAND-HELD TESTER)

- Stop the vehicle and face the tires straight ahead.
- Connect the hand-held tester to DLC3.
- Turn the ignition switch ON.
- Perform the steering angle adjust procedure from the VGRS menu.

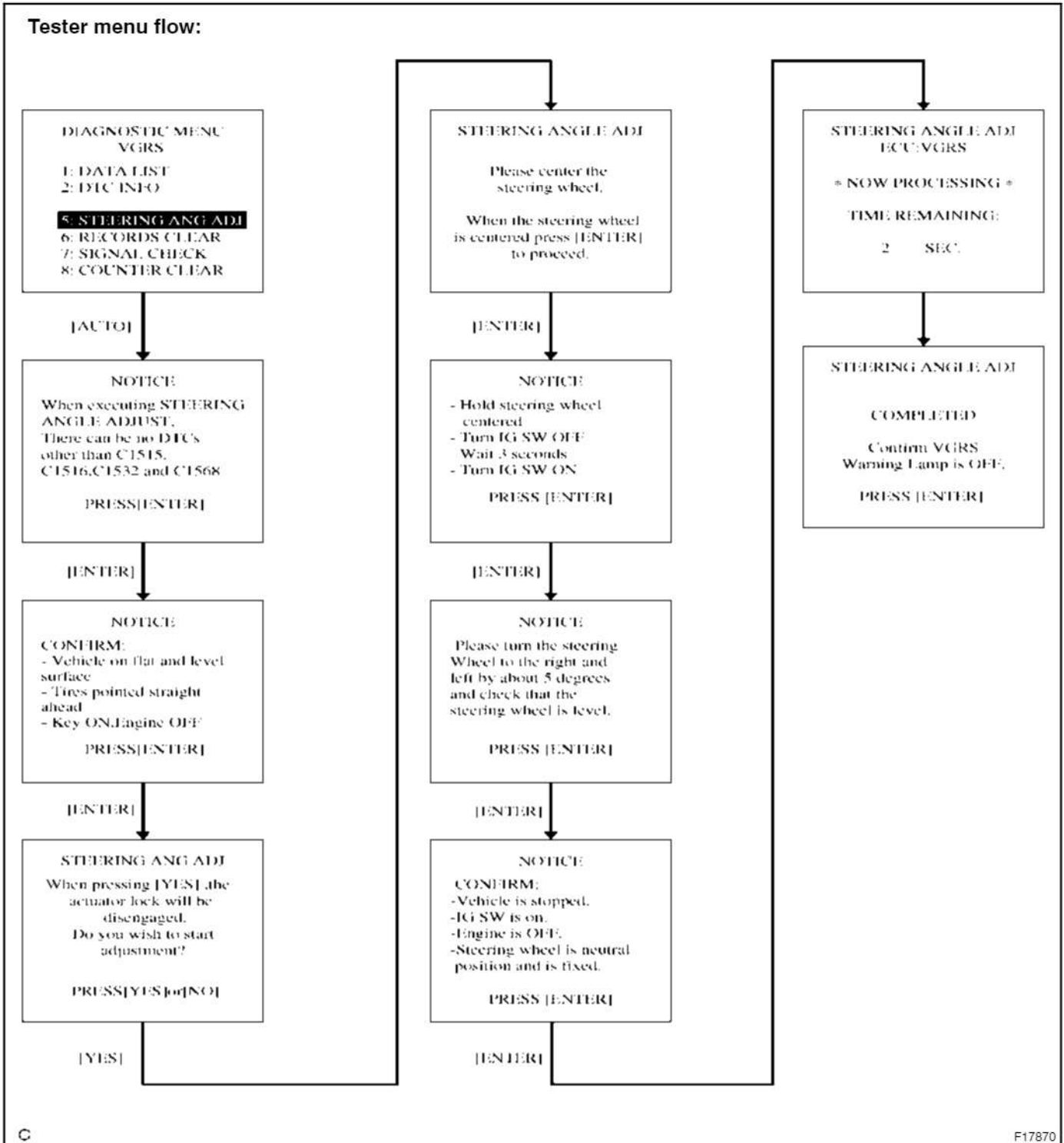

- (e) Follow the tester prompts to complete procedure.
- (f) Confirm that the VGRS warning light OFF.
- (g) Turn the ignition switch OFF.
- (h) Disconnect the hand-held tester.
- (i) Confirm normal VGRS light operation.
- (j) Start the engine.
- (k) Turn the steering wheel from lock to lock to check that it rotates approximately 2.4 turns.
- (l) Actuator angle sensor learning confirmation procedure:
 - (1) Start the engine.
 - (2) Turn the steering wheel from center to the left 90° and then back to center.
 - (3) Turn the steering wheel from center to the right 90° and then back to center.
 - (4) Confirm that the steering wheel is centered.
 - (5) Hold the steering wheel in the centered position for 3 seconds.
 - (6) Perform the following check procedure;
 - Turn the steering wheel slowly to the left.
 - While turning the steering wheel to the left, turn off the engine.
 - Continue to turn the steering wheel slowly to the left for 3 seconds.
 - (7) Repeat steps (1) to (6) 15 times.

NOTICE:

DTC C1568/68 requires that the fault occurs 5 consecutive times to set. The confirmation procedure must be performed multiple times to ensure the condition does not repeat.

- (8) Recheck for DTCs
 - If C1568/68 is set, repeat the procedure for a second time. If C1568/68 is set again, replace the VGRS actuator.
- (m) Drive vehicle to confirm steering wheel is centered.

COUNTER CLEARANCE

HINT:

- Perform the following procedure to clear the DTC C1555/55.
 - When clearing the DTCs in DTC clear menu of the hand-held tester or SST check wire, DTC C1555/55 cannot be cleared.
 - When clearing DTCs using the SST check wire, perform the VGRS system calibration.
1. **Connect the hand-held tester to DLC3.**
 2. **Turn the ignition switch ON.**
 3. **Perform the counter clearance procedure from the VGRS menu.**

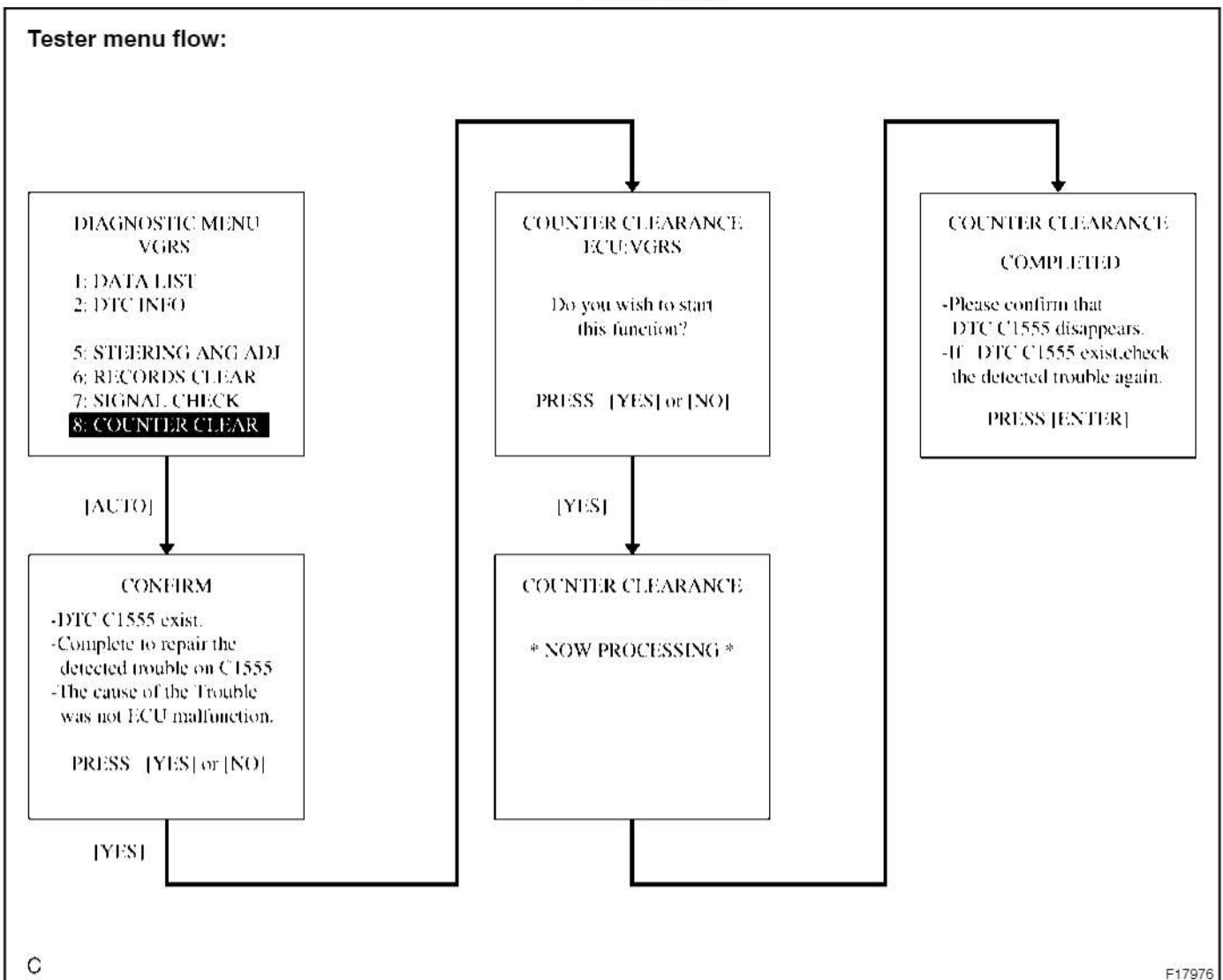

DIAGNOSTIC TROUBLE CODE CHART

HINT:

If a malfunction code is displayed during the DTC check, check the circuit indicated by the DTC. For details of each code, turn to the page for the respective "DTC No." in the DTC chart.

DTC chart of VGRS system:

DTC No. (See Page)	Detection Item	Trouble Area
C1511/11 (DI-114)	Steering angle sensor malfunction	<ul style="list-style-type: none"> • Steering angle sensor • Steering angle sensor circuit • VGRS ECU • Skid control ECU
C1515/15 (DI-123)	VGRS actuator neutral position is not initialized	<ul style="list-style-type: none"> • VGRS actuator • VGRS ECU
C1516/16 (DI-124)	VGRS actuator neutral position incomplete	<ul style="list-style-type: none"> • VGRS actuator • VGRS ECU
C1521/21 (DI-126)	VGRS actuator malfunction	<ul style="list-style-type: none"> • VGRS actuator • VGRS ECU
C1522/22 (DI-128)		
C1527/27 (DI-130)		
C1528/28 (DI-130)		
C1531/31 (DI-133)	VGRS ECU malfunction	<ul style="list-style-type: none"> • VGRS ECU
C1532/32 (DI-134)		
C1533/33 (DI-135)		
C1541/41 (DI-137)	Vehicle skid control system malfunction	<ul style="list-style-type: none"> • VSC system • VGRS ECU • Skid control ECU
C1549/49 (DI-140)	Vehicle skid control system communication malfunction	<ul style="list-style-type: none"> • Wire harness and connector • VGRS ECU • Skid control ECU
C1551/51 (DI-144)	IG power source voltage malfunction	<ul style="list-style-type: none"> • ECU-IG fuse • IG circuit • Charging system • VGRS ECU
C1552/52 (DI-146)	DC motor power source voltage	<ul style="list-style-type: none"> • VGRS fuse • Power source circuit • VGRS ECU
C1554/54 (DI-148)	Power source relay failure	<ul style="list-style-type: none"> • VGRS fuse • VGRS ECU
C1555/55 (DI-150)	Predriver malfunction	<ul style="list-style-type: none"> • Power source circuit • VGRS ECU
C1561/61 (DI-152)	Lock mechanism malfunction	<ul style="list-style-type: none"> • VGRS actuator • VGRS ECU
C1567/67 (DI-154)	Lock mechanism insertion malfunction	<ul style="list-style-type: none"> • VGRS actuator • VGRS ECU

C1568/68 (DI-156)	Lock holder deviation detection	•VGRS actuator
C1569/69 (DI-158)	Lock mechanism release incomplete	•VGRS actuator

PARTS LOCATION

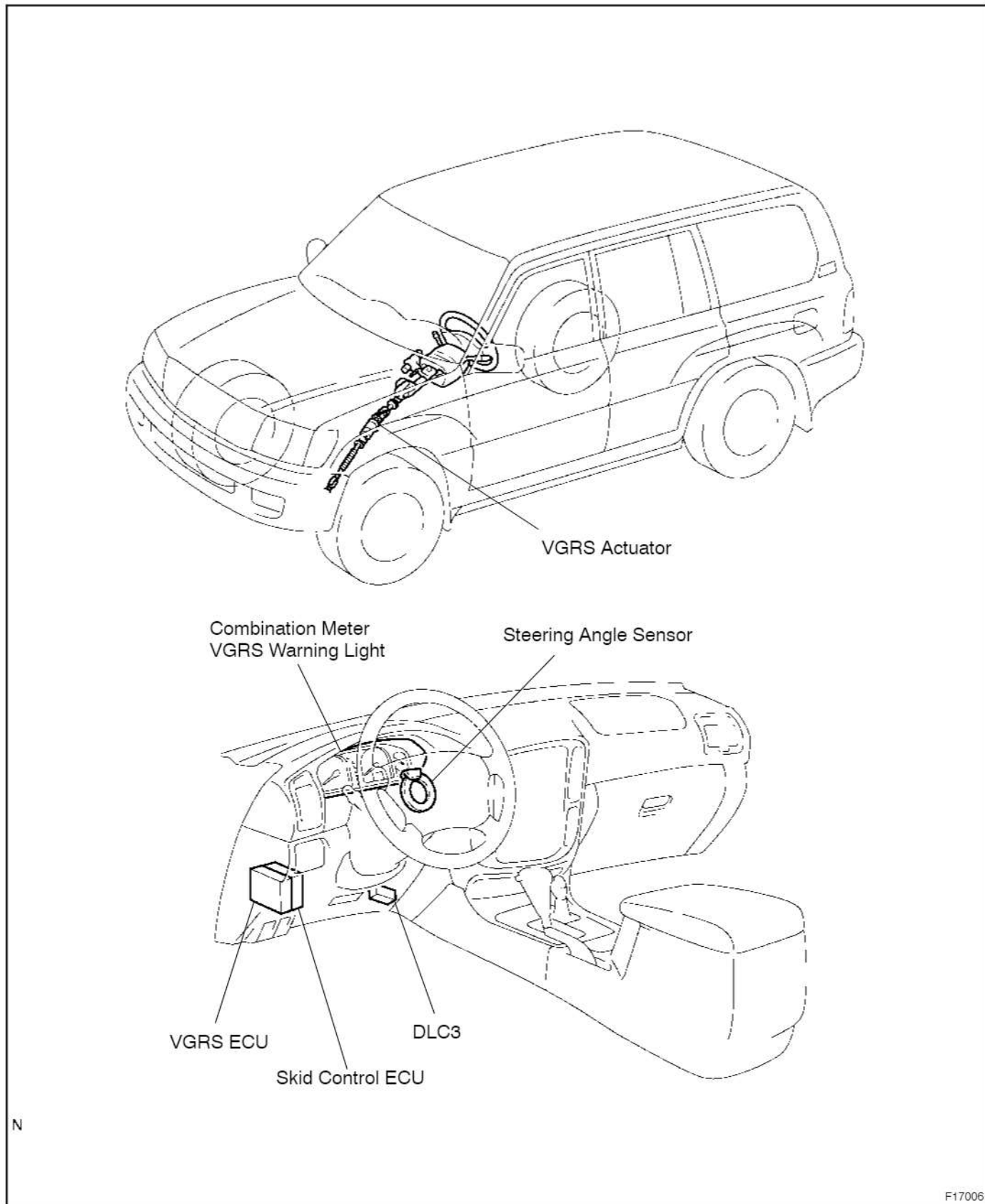

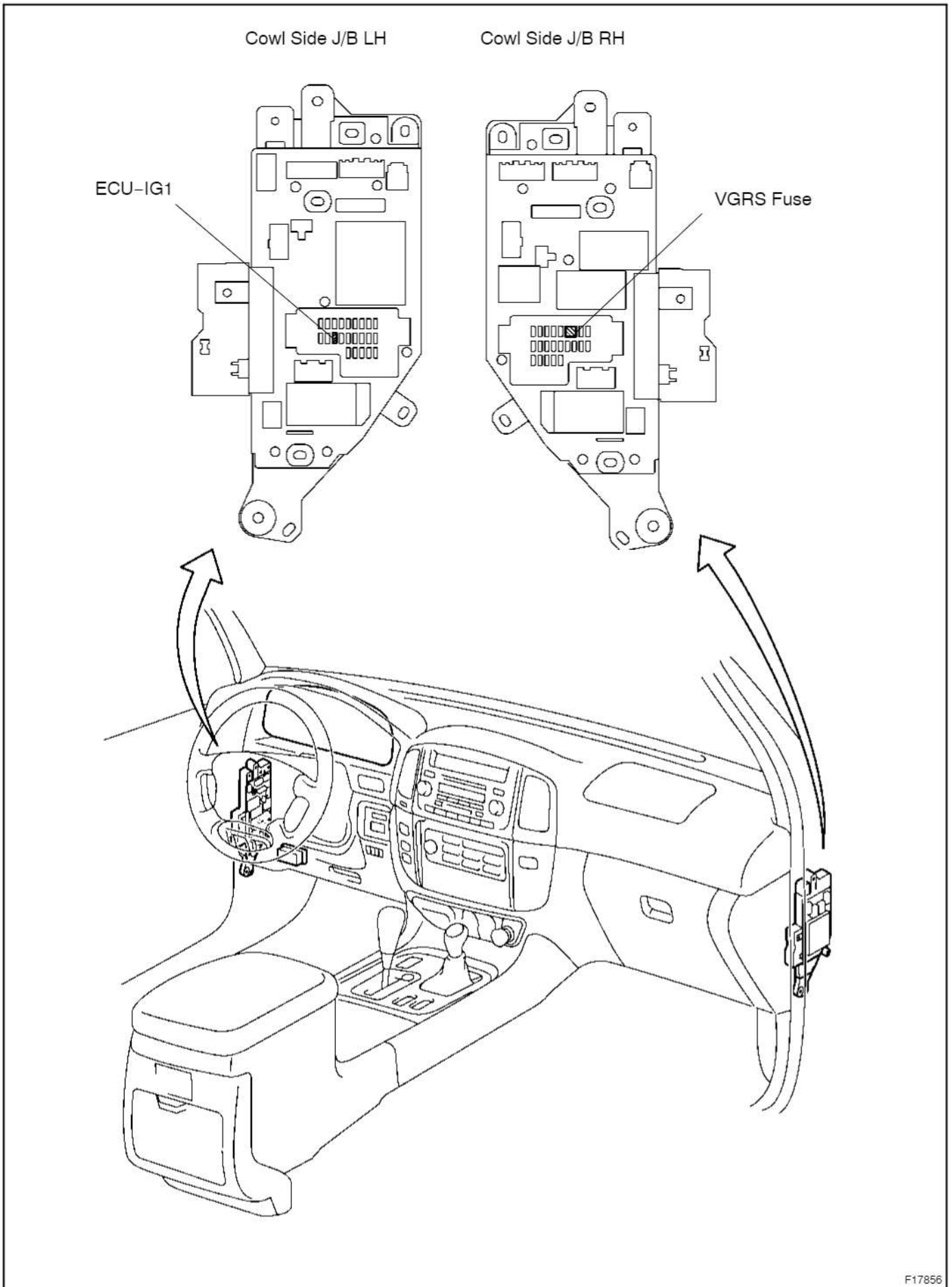

cardiagn.com

TERMINALS OF ECU

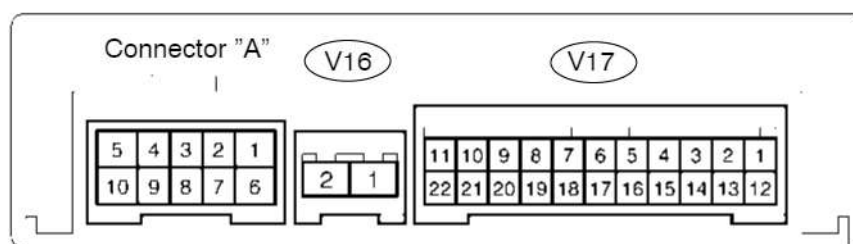

N

F17007

Symbols (Terminals No.)	Wiring Color	Condition	STD Voltage (V)
BMV (A1) – BMW (A6)	G – L	IG switch ON	0.1 to 1 Ω
MSW (A2) – MGND (A7)	W – GR	Turn the steering wheel	Repeat below 1 kΩ or Above 100 kΩ
LGND (A3) – Body ground	B – Body ground	IG switch ON	Below 1.0 V
MSU (A4) – MGND (A7)	Y – GR	Turn the steering wheel	Repeat below 1 kΩ or Above 100 kΩ
BMU (A5) – BMW (A6)	BR – L	IG switch OFF	0.1 to 1 Ω
BMW (A6) – BMV (A1)	L – G	IG switch OFF	0.1 to 1 Ω
MGND (A7) – Body ground	GR – Body ground	Always	Continuity
MSV (A8) – MGND (A7)	G–R – GR	Turn the steering wheel	Repeat below 1 kΩ or Above 100 kΩ
MV (A10) – Body ground	R – Body ground	Always	Continuity
MSW (A2) – GND (V17 – 6 or 22)	W – W-B	Turn the steering wheel	Repeat below 1 or Above 4 V
LGND (A3) – GND (V17 – 6 or 22)	B – W-B	IG switch ON	Below 1.0 V
MSU (A4) – GND (V17 – 6 or 22)	Y – W-B	Turn the steering wheel	Repeat below 1 or Above 4 V
MGND (A7) – GND (V17 – 6 or 22)	GR – W-B	Always	Below 1 V
MSV (A8) – GND (V17 – 6 or 22)	G–R – W-B	Turn the steering wheel	Repeat below 1 or Above 4 V
PIG (V16 – 1) – PGND (V16 – 2)	W – W-B	Idling	9 to 16 V
PGND (V16 – 2) – Body ground	W-B – Body ground	Always	Below 1 V
TS (V17 – 1) – GND (V17 – 6 or 22)	W – W-B	IG switch ON	10 to 14 V
+BI (V17 – 2) – GND (V17 – 6 or 22)	LG – W-B	IG switch ON	10 to 14 V
IG (V17 – 3) – GND (V17 – 6 or 22)	B-W – W-B	IG switch ON	10 to 14 V
SS1 (V17 – 4) – GND (V17 – 6 or 22)	B-Y – W-B	Turn the steering wheel	Repeat below 1 or Above 4 V
SS3 (V17 – 5) – GND (V17 – 6 or 22)	B-L – W-B	Turn the steering wheel	Repeat below 1 or Above 4 V

LAND CRUISER (W/G) SUP (RM1072E)

GND (V17 - 6) - Body ground	W-B - Body ground	Always	Below 1.0 V
AFS+ (V17 - 7) - AFS- (V17 - 17)	LG-R - GR-B	IG switch ON	Pulse generation
VSC+ (V17 - 8) - VSC- (V17 - 18)	V - Y-G	IG switch ON	Pulse generation
TA+ (V17 - 9) - TA- (V17 - 21)	R - G-W	IG switch ON	Pulse generation
FRO (V17 - 11) - GND (V17 - 6 or 22)	R-W - W-B	Vehicle driving at about 20 km/h (12 mph)	Pulse generation
TC (V17 - 12) - GND (V17 - 6 or 22)	P-B - W-B	IG switch ON	10 to 14 V
+BO (V17 - 13) - GND (V17 - 6 or 22)	L-W - W-B	Always	10 to 14 V
SIL (V17 - 14) - GND (V17 - 6 or 22)	V-W - W-B	IG switch ON	10 to 14 V
SS2 (V17 - 15) - GND (V17 - 6 or 22)	G-W - W-B	Turn the steering wheel	Repeat below 1 or Above 4 V
WL (V17 - 16) - GND (V17 - 6 or 22)	R-B - W-B	After IG switch ON and VGRS warning light turns on for 1.5 sec. then it goes off	Below 1.0 V
FLO (V17 - 20) - GND (V17 - 6 or 22)	R-Y - W-B	Vehicle driving at about 20 km/h (12 mph)	Pulse generation
GND2 (V17 - 22) - Body ground	W-B - Body ground	Always	Below 1.0 V

PROBLEM SYMPTOMS TABLE

If a normal code is displayed during the DTC check but the problem still occurs, check the circuits for each problem symptom in the order given in the table below and proceed to the relevant troubleshooting page.

Symptom	Suspected Area	See page
Steering wheel off-center	Steering wheel off-center	DI-162
VGRS stops and does not operate	<ol style="list-style-type: none"> 1. Actuator temperature above -30°C 2. IG power source circuit 3. Skid control ECU 4. IG, PIG power supply system 5. Power steering system <ol style="list-style-type: none"> 6. Only when 1. to 5. are all normal and the problem is still occurring, replace the VGRS ECU. 	<p style="text-align: center;">-</p> <p style="text-align: center;">DI-144</p> <p style="text-align: center;">-</p> <p style="text-align: center;">DI-146</p> <p style="text-align: center;">SR-3</p> <p style="text-align: center;">SR-20</p> <p style="text-align: center;">-</p>
Steering angle is different from right to left	Check by following operation	DI-165
Abnormal noise and vibration is produced in the steering wheel	VGRS actuator	DI-166
VGRS warning light abnormal	<ol style="list-style-type: none"> 1. VGRS warning light circuit 2. Tc and CG terminal circuit 3. VGRS ECU 	<p style="text-align: center;">DI-167</p> <p style="text-align: center;">DI-169</p> <p style="text-align: center;">-</p>

CIRCUIT INSPECTION

DTC	C1511 / 11	Steering Angle Sensor Malfunction
------------	-------------------	--

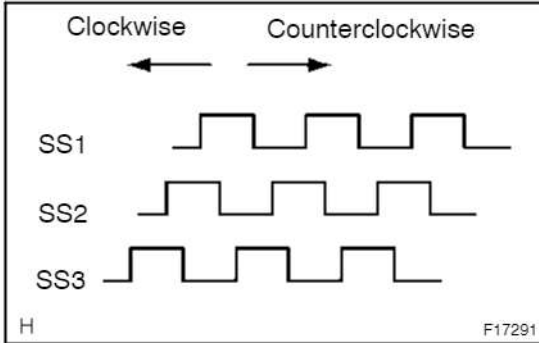

CIRCUIT DESCRIPTION

The VGRS ECU receives the steering sensor signals (SS1, SS2, SS3), and judges the steering condition to drive the VGRS actuator.

When the steering sensor signal is abnormal, the VGRS ECU records the DTC and illuminates the VGRS warning light.

DTC No.	DTC Detecting Condition	Trouble Area
C1511/11	The system detects a momentary interruption of the steering angle sensor signal (SS1, SS2, SS3) 10 times, or an open circuit for more than 0.12 sec.	<ul style="list-style-type: none"> • Steering angle sensor • Steering angle sensor circuit • VGRS ECU • Skid control ECU

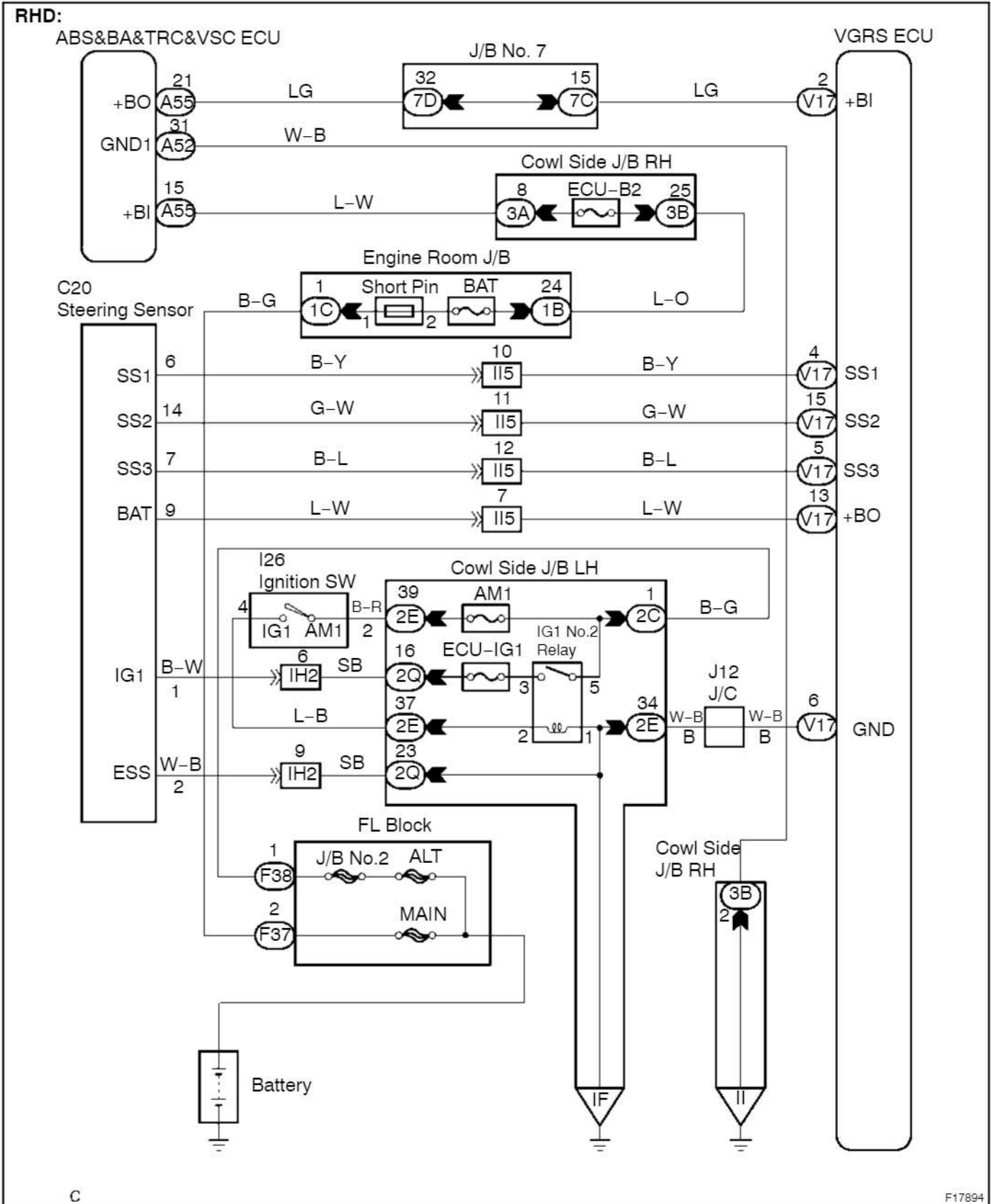

cardiagn.com

INSPECTION PROCEDURE

HINT:

- Determine the trouble area by checking the steering sensor signal using hand-held tester.
- When not using hand-held tester, go to step 3.

1	Observe the data for SS1, SS2, SS3 on the hand-held tester.
----------	--

PREPARATION:

- Connect the hand-held tester to the DLC3.
- Start the engine.

CHECK:

Check each steering sensor signal (SS1, SS2, SS3) while slowly turning the steering wheel.

OK:

STR SENS1: High or Low

STR SENS2: High or Low

STR SENS3: High or Low

All OK	A
All NG	B
Other	C

A	Replace VGRS ECU.
C	Go to step 3.

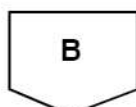

Proceed to step 2.

2	Inspect power supply voltage of steering angle sensor.
----------	---

HINT:

- When a malfunction is found in the power supply voltage of the steering angle sensor, the sensor outputs become abnormal.
- The power supply has 2 systems, IG and BAT.

PREPARATION:

- (a) Turn the ignition switch OFF.
- (b) Disconnect the steering angle sensor connector (C20).
- (c) Turn the ignition switch ON.

CHECK:

- (a) Measure voltage between terminals 1 and 2 of the steering angle sensor harness side connector.

OK:**10 to 14 V**

- (b) Measure voltage between terminals 9 and 2 of the steering angle sensor harness side connector.

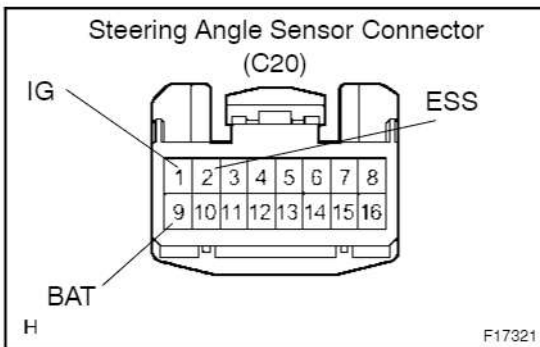
OK:**10 to 14 V**

OK	A
NG (IG power supply terminals 1 and 2)	B
NG (BAT power supply terminals 9 and 2)	C

B**Check or replace harness or connector.****C****Go to step 4.****A****Proceed to step 3.**

3 Inspect output of steering angle sensor.

HINT:

Check the output when slowly turning the steering wheel to judge whether the sensor is good.

PREPARATION:

- Turn the ignition switch OFF.
- Disconnect the VGRS ECU connector (V17).
- Turn the ignition switch ON.

CHECK:

When slowly turning the steering wheel, measure the resistance between terminals of the steering angle sensor connector (C20).

OK:

Symbols (Terminals No.)	Resistance
SS1 - ESS (6) - (2)	Alternates below 1 k Ω and above 100 k Ω
SS2 - ESS (14) - (2)	
SS3 - ESS (7) - (2)	

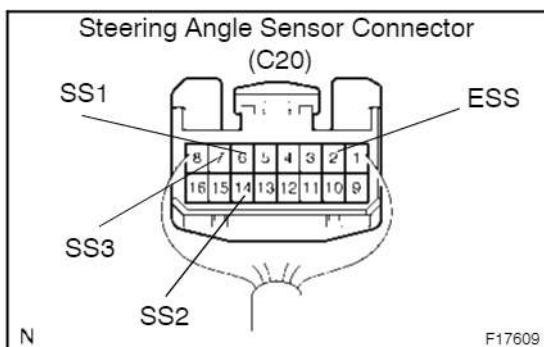
OK**Go to step 8.****NG****Replace steering angle sensor.**

4 Check voltage between terminal +BO and GND of VGRS ECU.

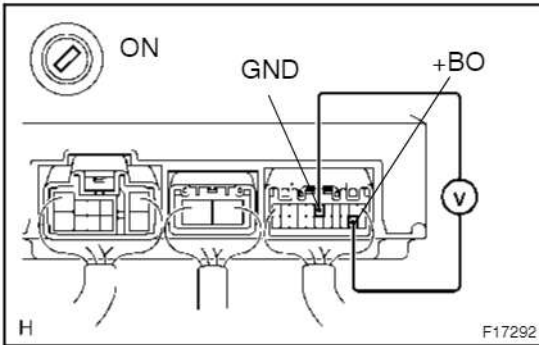

PREPARATION:

Turn the ignition switch ON.

CHECK:

Measure the voltage between terminal +BO and GND of the VGRS ECU.

OK:

10 to 14V

OK

Check and repair the wire harness and connector between steering angle sensor and VGRS ECU.

NG

5 Check voltage between terminal +BI and GND of VGRS ECU.

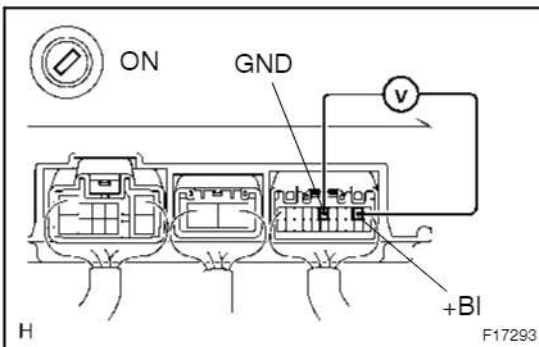

PREPARATION:

Turn the ignition switch ON.

CHECK:

Measure the voltage between terminal +BI and GND of the VGRS ECU.

OK:

10 to 14 V

OK

Replace VGRS ECU.

NG

Proceed to step 6.

6 Check voltage between terminal +BO and GND of skid control ECU.

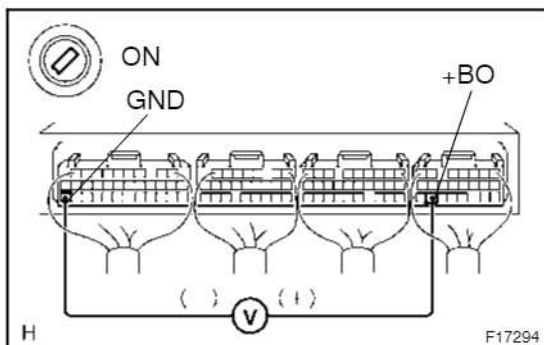

PREPARATION:

Turn the ignition switch ON.

CHECK:

Measure the voltage between terminal +BO and GND of the skid control ECU.

OK:

10 to 14 V

OK

Check and repair the wire harness and connector between skid control ECU and VGRS ECU.

NG

7 Check voltage between terminal +BI and GND of skid control ECU.

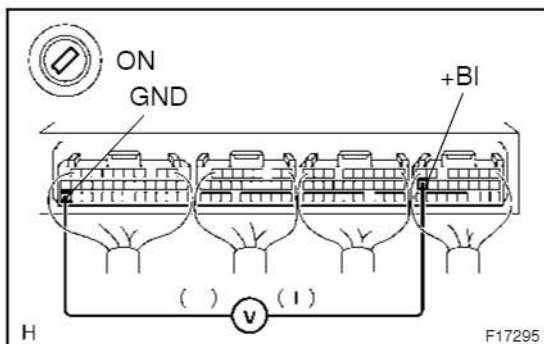

PREPARATION:

Turn the ignition switch ON.

CHECK:

Measure the voltage between terminal +BI and GND of the skid control ECU.

OK:

10 to 14 V

OK

Replace skid control ECU.

NG

Repair or replace +BI circuit.

8	Check for open or short circuit in harness and connector between steering angle sensor and VGRS ECU (See page IN-38).
----------	--

PREPARATION:

- (a) Turn the ignition switch OFF.
- (b) Disconnect the steering angle sensor connector and VGRS ECU connector.

CHECK:

Check the continuity between each terminal SS1, SS2 and SS3 of the steering angle sensor connector and the VGRS ECU connector.

OK:

Continuity

CHECK:

Check the continuity between each terminal SS1, SS2 and SS3 of the VGRS ECU connector and body ground.

OK:

No continuity

NG

Repair or replace harness and connector.

OK

Replace VGRS ECU.

DTC	C1515 / 15	VGRS Actuator Neutral Position Not Initial-ized
------------	-------------------	--

CIRCUIT DESCRIPTION

This code is set when the VGRS ECU or actuator has been replaced.

DTC No.	DTC Detecting Condition	Trouble Area
C1515/15	When the VGRS actuator angle adjustment has not been performed.	<ul style="list-style-type: none"> •VGRS actuator •VGRS ECU

INSPECTION PROCEDURE

1	Are any other VGRS codes present?
----------	--

YES

Repair circuit indicated by DTC output.

NO

2	Perform VGRS system calibration (See page DI-91).
----------	--

NEXT

3	Is DTC C1516/16 output? (VGRS actuator angle adjustment did not complete normally)
----------	---

NO

VGRS system calibration is completed.

YES

(See page DI-124)

DTC	C1516 / 16	VGRS Actuator Neutral Position Incomplete
------------	-------------------	--

CIRCUIT DESCRIPTION

This code is set when the VGRS system calibration procedure does not complete normally.

DTC No.	DTC Detecting Condition	Trouble Area
C1516/16	The VGRS actuator angle adjustment did not complete normally.	<ul style="list-style-type: none"> •VGRS actuator •VGRS ECU

INSPECTION PROCEDURE

1	Clear DTC (See page DI-91).
----------	------------------------------------

NEXT

2	Perform VGRS system calibration (See page DI-100).
----------	---

NEXT

3	Is DTC C1516/16 output?
----------	--------------------------------

NO → **VGRS system calibration is completed.**

YES

4	Is DTC C1532/32 output?
----------	--------------------------------

YES → **Replace VGRS ECU.**

NO

Proceed to step 5.

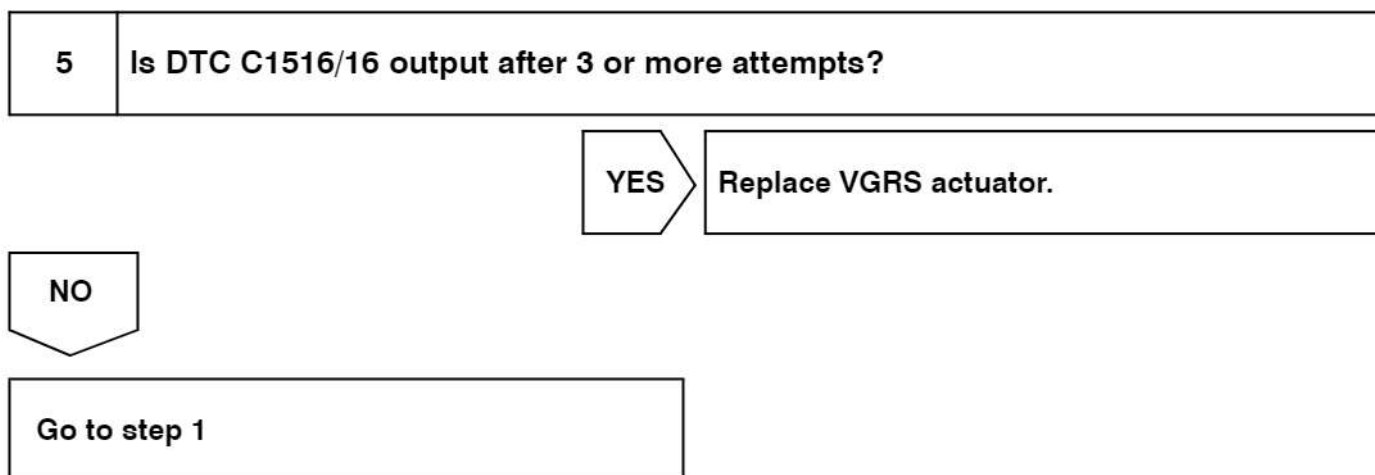

DTC	C1521 / 21	VGRS Actuator Malfunction
------------	-------------------	----------------------------------

CIRCUIT DESCRIPTION

The VGRS ECU drives the actuator while turning the steering wheel to set the gear ratio. It detects the current flowing into the actuator motor driving circuit. When the VGRS ECU detects excessive current, it records the DTC, turns on the VGRS warning light, and stops VGRS operation.

DTC No.	DTC Detecting Condition	Trouble Area
C1521/21	More than 60 A of current flows in the motor power source circuit for 0.1 sec or more.	<ul style="list-style-type: none"> •VGRS actuator •VGRS ECU

WIRING DIAGRAM

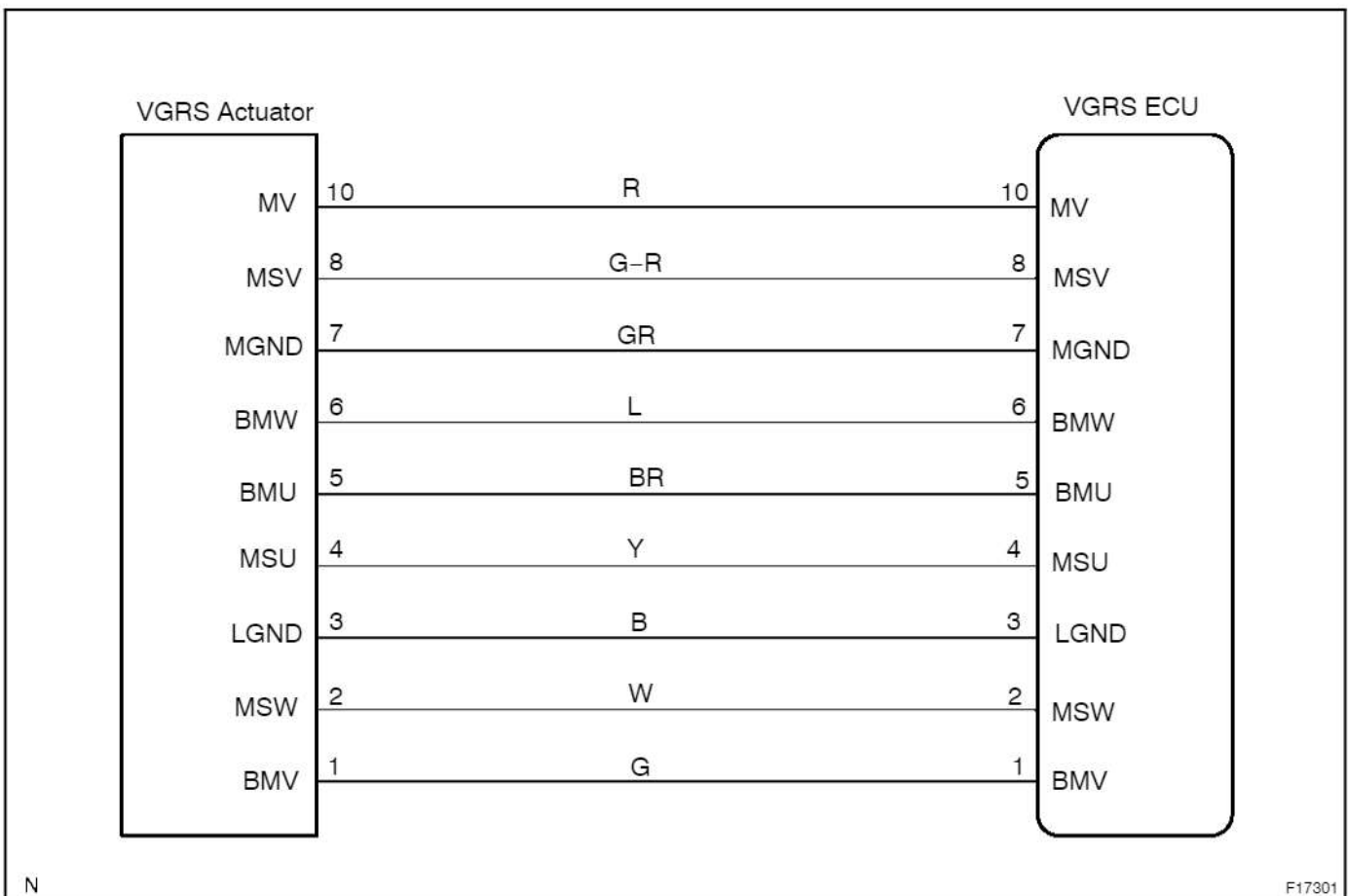

INSPECTION PROCEDURE

HINT:

When DTC C1521/21 is output, a short circuit inside the actuator or inside the ECU is suspected.

1 Inspect the VGRS actuator.

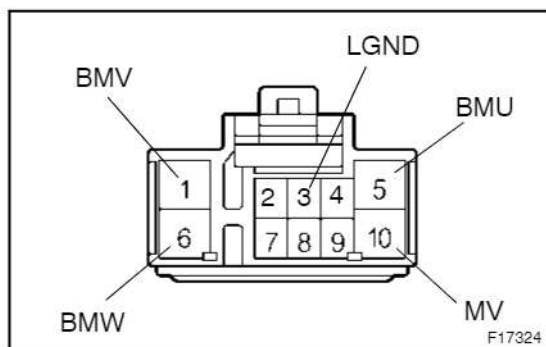

PREPARATION:

- Turn the ignition switch OFF.
- Disconnect the actuator connector from the VGRS ECU.

CHECK:

- Measure resistance between terminals.

OK:

Symbols (Terminals)	Resistance
BMV (1) - BMU (5)	0.1 Ω to 1 Ω
BMV (1) - BMW (6)	
BMU (5) - BMW (6)	
MV (10) - LGND (3)	1 Ω to 100 Ω

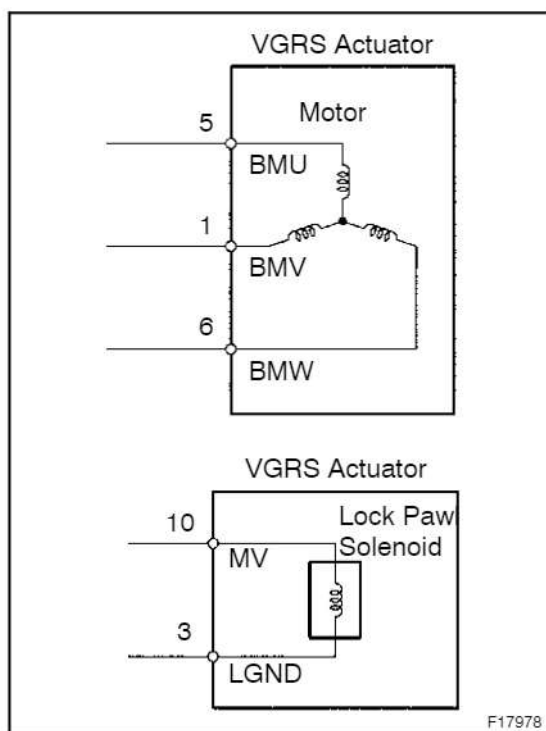

- Check continuity between terminals of actuator connector and body ground.

OK:

Symbols (Terminals)	Specified condition
BMV (1) - Body ground	No Continuity
BMU (5) - Body ground	
BMW (6) - Body ground	
MV (10) - Body ground	
LGND (3) - Body ground	

NG

Replace VGRS actuator.

OK

Replace VGRS ECU.

DTC	C1522 / 22	VGRS Actuator Malfunction
------------	-------------------	----------------------------------

CIRCUIT DESCRIPTION

The VGRS ECU drives the actuator based on the steering angle sensor signal and the vehicle speed signal. If the VGRS ECU detects excessive current flowing into the actuator, or a malfunction inside the ECU, it turns on the warning light, records the DTC, and stops VGRS operation.

DTC No.	DTC Detecting Condition	Trouble Area
C1522/22	The system detects a malfunction in the motor drive circuit.	<ul style="list-style-type: none"> •VGRS actuator •VGRS ECU

WIRING DIAGRAM

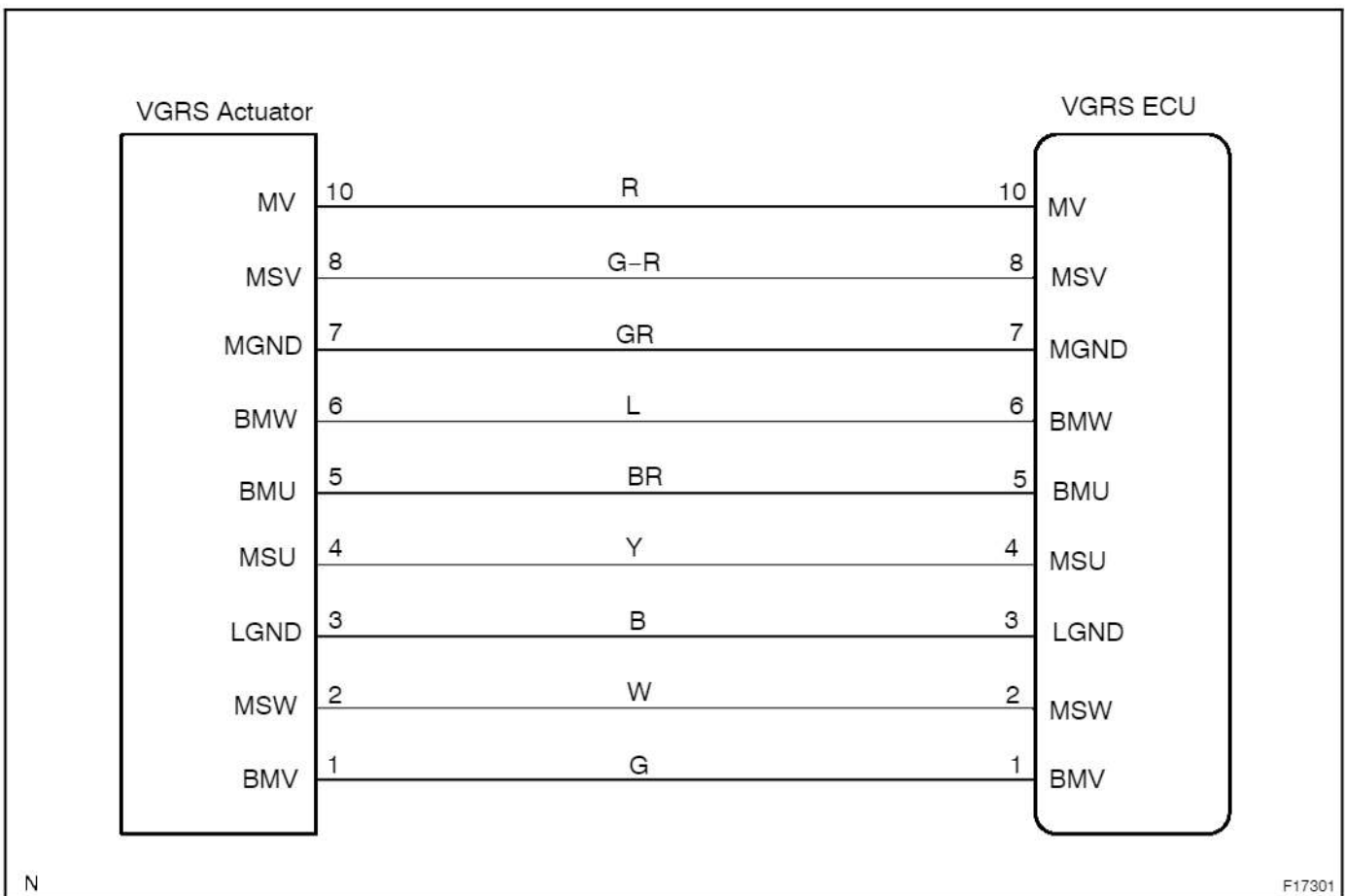

INSPECTION PROCEDURE

HINT:

Since only the actuator can be checked in this procedure, if it is normal, the VGRS ECU is faulty.

1 Inspect the VGRS actuator for an open circuit.

PREPARATION:

- Turn the ignition switch OFF.
- Disconnect the actuator connector from the VGRS ECU.

CHECK:

- Check resistance between terminals of the actuator connector.

OK:

Symbols (Terminals)	Resistance
BMV (1) - BMU (5)	0.1 Ω to 1 Ω
BMU (5) - BMW (6)	

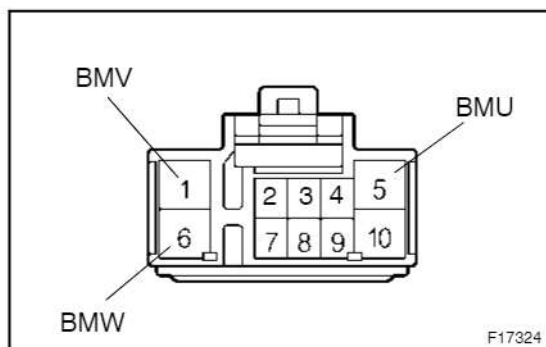

- Check continuity between terminals of the actuator connector and body ground.

OK:

Symbols (Terminals)	Specified condition
BMV (1) - Body ground	No Continuity
BMU (5) - Body ground	
BMW (6) - Body ground	

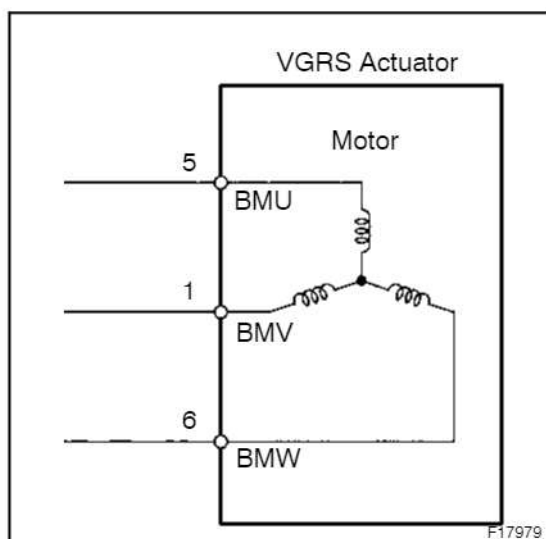

OK

Replace VGRS ECU.

NG

Replace VGRS actuator.

DTC	C1527 / 27, C1528 / 28	VGRS Actuator Malfunction
------------	-------------------------------	----------------------------------

CIRCUIT DESCRIPTION

The VGRS ECU detects the actuator operation with the turning angle sensor. If a malfunction in the turning angle sensor is found, the VGRS ECU turns on the warning light and records the DTC.

DTC No.	DTC Detecting Condition	Trouble Area
C1527/27	The system detects that the difference between the actuator target angle and the actuator position is approx. 30° or more for 1 sec.	<ul style="list-style-type: none"> •VGRS actuator •VGRS ECU
C1528/28	The system detects a momentary interruption of the motor rotating angle sensor signal (MSU, MSV and MSW) 10 times or an open circuit for 0.12 sec. minimum.	

WIRING DIAGRAM

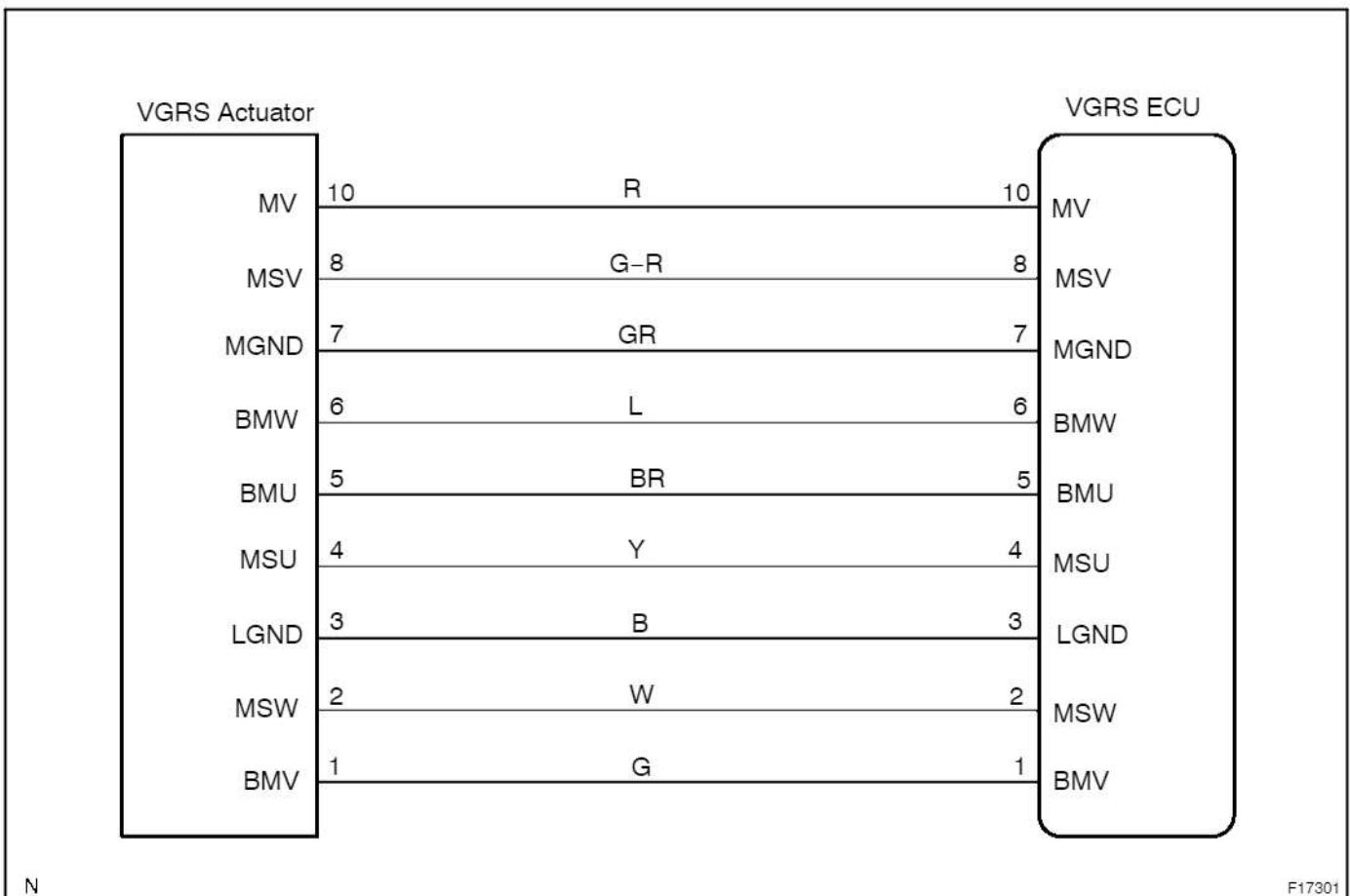

INSPECTION PROCEDURE

1	Check MV wire for open circuit.
---	--

PREPARATION:

Turn the ignition switch ON.

CHECK:

Check DTC (See page DI-91).

OK:

DTC C1561/61 is output

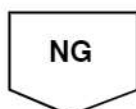
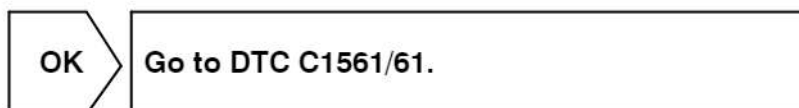

2	Observe the data for MTR REV ANG U, V, W on the hand-held tester.
---	--

HINT:

Determine the trouble area by checking the motor revolution angle sensor signal with hand-held tester. When not using hand-held tester, go to step 3.

PREPARATION:

- (a) Connect the hand-held tester to DLC3.
- (b) Start the engine.
- (c) Using the hand-held tester, display the data list.

CHECK:

Check the motor revolution angle sensor signal when slowly turning the steering wheel referring to the data list.

OK:

MTR REV ANG U: High or Low
MTR REV ANG V: High or Low
MTR REV ANG W: High or Low

All OK	A
All NG	B
Others	C

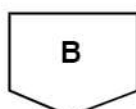
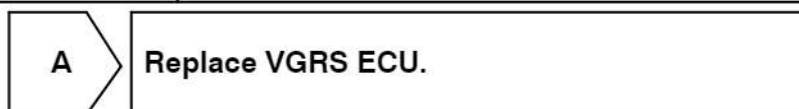

Proceed to step 3.

3 Check GND circuit of motor revolution angle sensor.

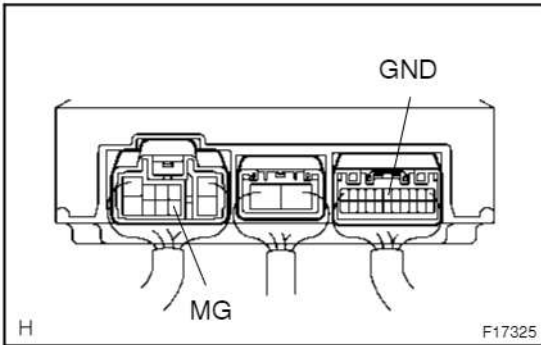

PREPARATION:

Turn the ignition switch OFF.

CHECK:

Check continuity between terminal MG and GND of the VGRS ECU.

OK:

Continuity

NG → Replace VGRS ECU.

OK

4 Check motor revolution angle sensor signal.

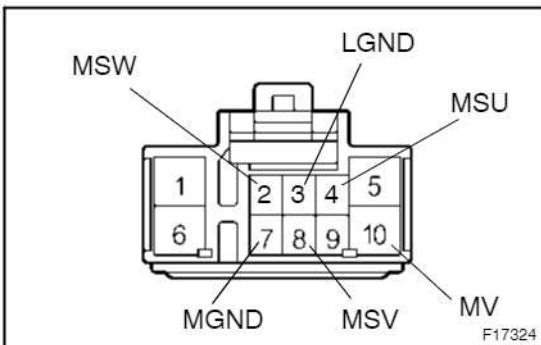

PREPARATION:

Disconnect the VGRS actuator connector.

NOTICE:

Do not apply 12 V to MV for more than 3 minutes.

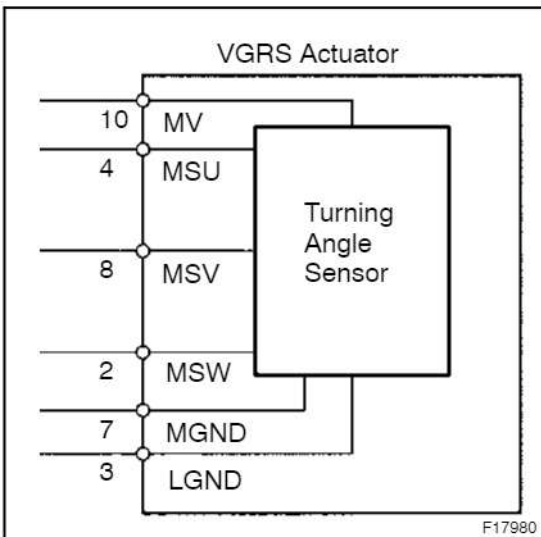

CHECK:

- (a) Connect a jumper wire from Batt (+) to MV, and another jumper wire from body ground to LGND.
- (b) Measure the resistance between terminals while slowly turning the steering wheel. The steering wheel must be turned a maximum of $\pm 10^\circ$ from center.

OK:

Symbols (Terminals)	Resistance
MSW (2) - MGND (7)	Below 1 kΩ to above 100 kΩ
MSU (4) - MGND (7)	
MSV (8) - MGND (7)	

NG → Replace VGRS actuator.

OK

Replace the VGRS ECU.
LAND CRUISER (W/G) SUP (RM1072E)

DTC	C1531 / 31	VGRS ECU Malfunction
------------	-------------------	-----------------------------

CIRCUIT DESCRIPTION

DTC No.	DTC Detecting Condition	Trouble Area
C1531/31	The system detects a malfunction inside the ECU.	•VGRS ECU

INSPECTION PROCEDURE

1	Check vehicle conditions when the warning light comes on.
----------	--

CHECK:

Just before the light comes on, was the engine stalled, or the battery dead or the terminal disconnected?

NO

Replace VGRS ECU.

YES

2	Record and clear the DTCs. Perform the steering angle sensor initialization.
----------	---

Did the DTC C1531/31 reappear?

YES

Replace VGRS ECU.

NO

Condition corrected by the steering angle initialization.

DTC	C1532 / 32	VGRS ECU Malfunction
------------	-------------------	-----------------------------

CIRCUIT DESCRIPTION

DTC No.	DTC Detecting Condition	Trouble Area
C1532/32	The system detects a malfunction inside the ECU.	•VGRS ECU

INSPECTION PROCEDURE

1	Check for other VGRS DTCs.
----------	-----------------------------------

CHECK:

Are there any other VGRS DTCs?

NO

Replace VGRS ECU.

YES

2	Perform troubleshooting for remaining DTCs.
----------	--

NEXT

After repairing other DTCs, if C1532/32 still exists, replace VGRS ECU.

DTC	C1533 / 33	VGRS ECU Malfunction
------------	-------------------	-----------------------------

CIRCUIT DESCRIPTION

DTC No.	DTC Detecting Condition	Trouble Area
C1533/33	The system detects a temperature malfunction inside of the ECU.	•VGRS ECU

INSPECTION PROCEDURE

HINT:

- Check the VGRS thermistor temperature using hand-held tester.
- When not using hand-held tester, go to step 3.

1	Read value of the hand-held tester.
----------	--

PREPARATION:

- Connect the hand-held tester to DLC3.
- Start the engine.
- Display the VGRS data list.

CHECK:

Is the thermistor temperature below -40°C or above 130°C .

YES

Replace VGRS ECU.

NO

2	With the vehicle stopped, perform the steering operation of lock to lock 10 times.
----------	---

Did the thermistor temperature change by less than 3°C ?

NO

Replace VGRS ECU.

YES

This is not a malfunction, because C1533/33 may be set by the sudden change in the thermistor temperature due to extreme VGRS operation.

3 Thermistor temperature sensor check.**PREPARATION:**

- (a) Record and clear the VGRS DTCs.
- (b) Start the engine.
- (c) With the vehicle stopped, perform steering operation of lock to lock about 15 times.
- (d) After steering operation, leave the vehicle for about 10 minutes with the engine ON.
- (e) After leaving the vehicle for 10 minutes, perform steering operation 10 times again.
- (f) Leave the vehicle for 1 minute with the engine ON.

CHECK:

Check that DTC C1533/33 reappears.

YES**Replace VGRS ECU.****NO**

This is not a malfunction, because C1533/33 may be set by the sudden change in the thermistor temperature due to extreme VGRS operation.

DTC	C1541 / 41	Vehicle Skid Control System Malfunction
------------	-------------------	--

CIRCUIT DESCRIPTION

The VGRS system will illuminate the warning light and this DTC will be recorded when some ABS/VSC system DTCs are set.

DTC No.	DTC Detecting Condition	Trouble Area
C1541/41	The system receives the information about a malfunction in the steering sensor signal or in the vehicle speed signal from ABS/VSC.	<ul style="list-style-type: none"> •VSC system •VGRS ECU •Skid control ECU

WIRING DIAGRAM

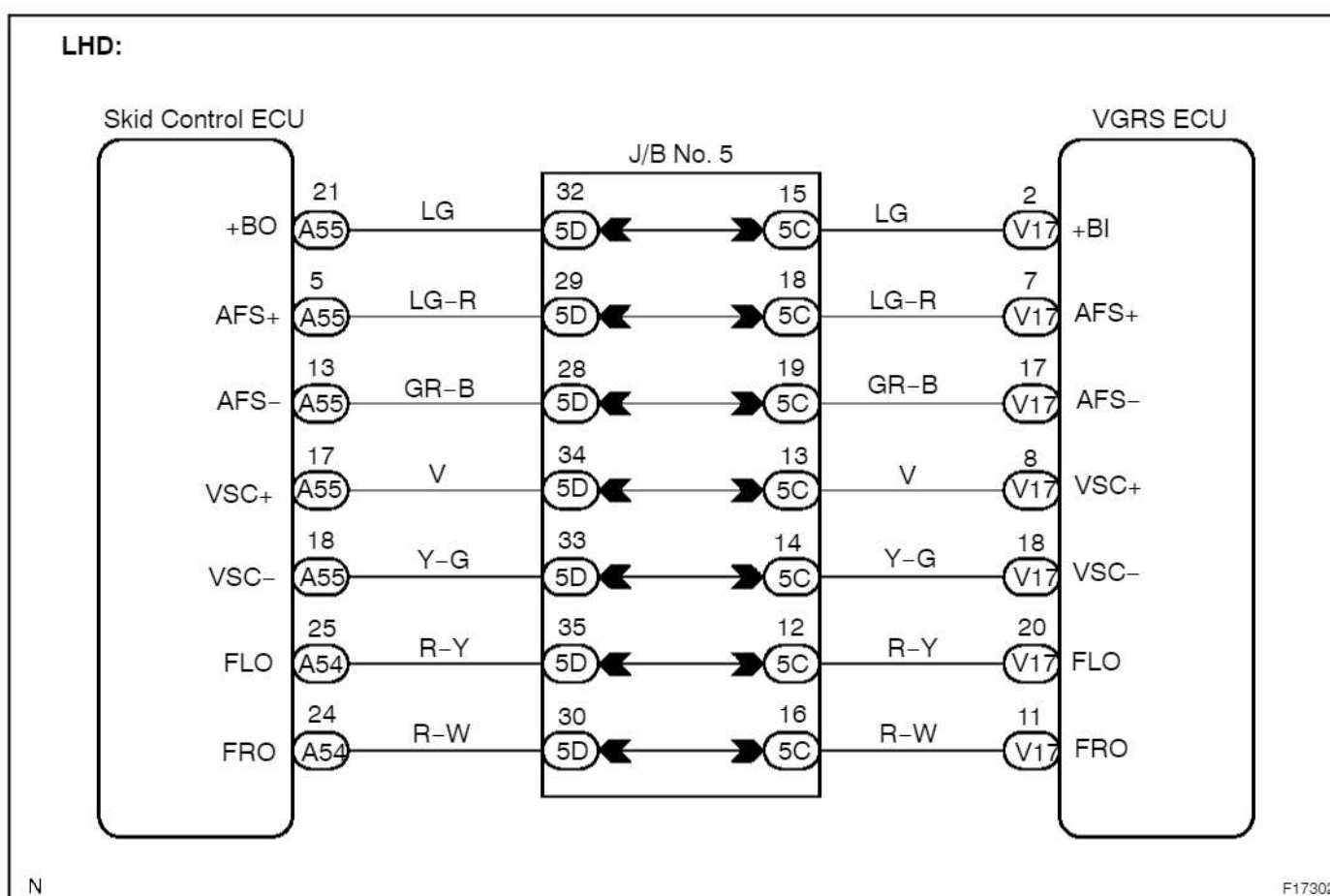

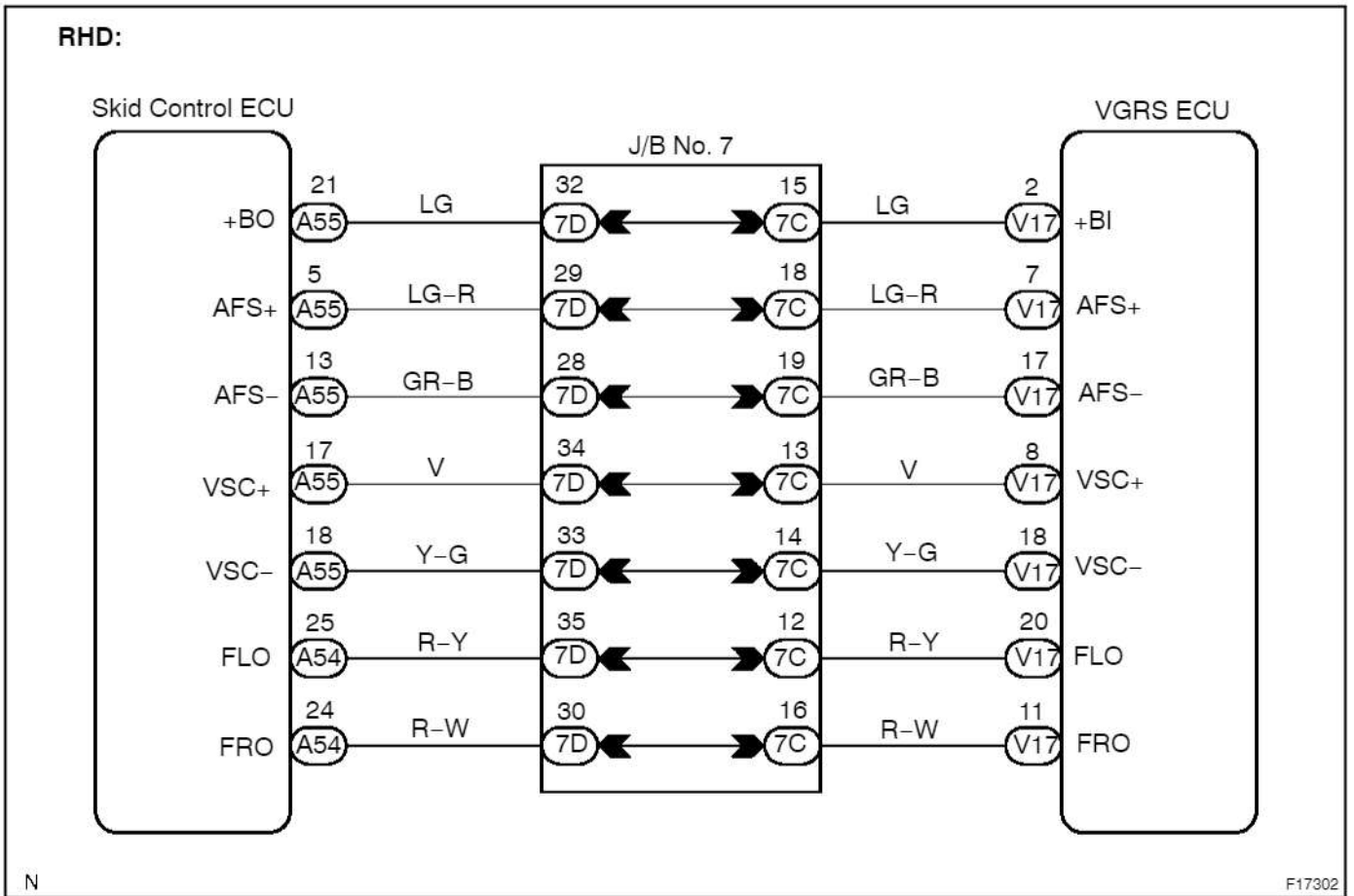

INSPECTION PROCEDURE

1	Check the ABS/VSC for DTCs (See Pub. No. RM970E, page DI-185).
----------	---

Are any ABS/VSC DTCs present?

YES**Repair the ABS/VSC system according to the DTC output.****NO****Replace VGRS ECU.**

DTC	C1549 / 49	Vehicle Skid Control System Communication Malfunction
------------	-------------------	--

CIRCUIT DESCRIPTION

The VGRS ECU communicates with the skid control ECU. However, if any problems in this communication occur, the VGRS ECU turns on the warning light, records the DTC and stops VGRS operation.

DTC No.	DTC Detecting Condition	Trouble Area
C1549/49	The system detects a communication malfunction from the skid control ECU for 3 seconds.	<ul style="list-style-type: none"> •Wire harness and connector •VGRS ECU •Skid control ECU

WIRING DIAGRAM

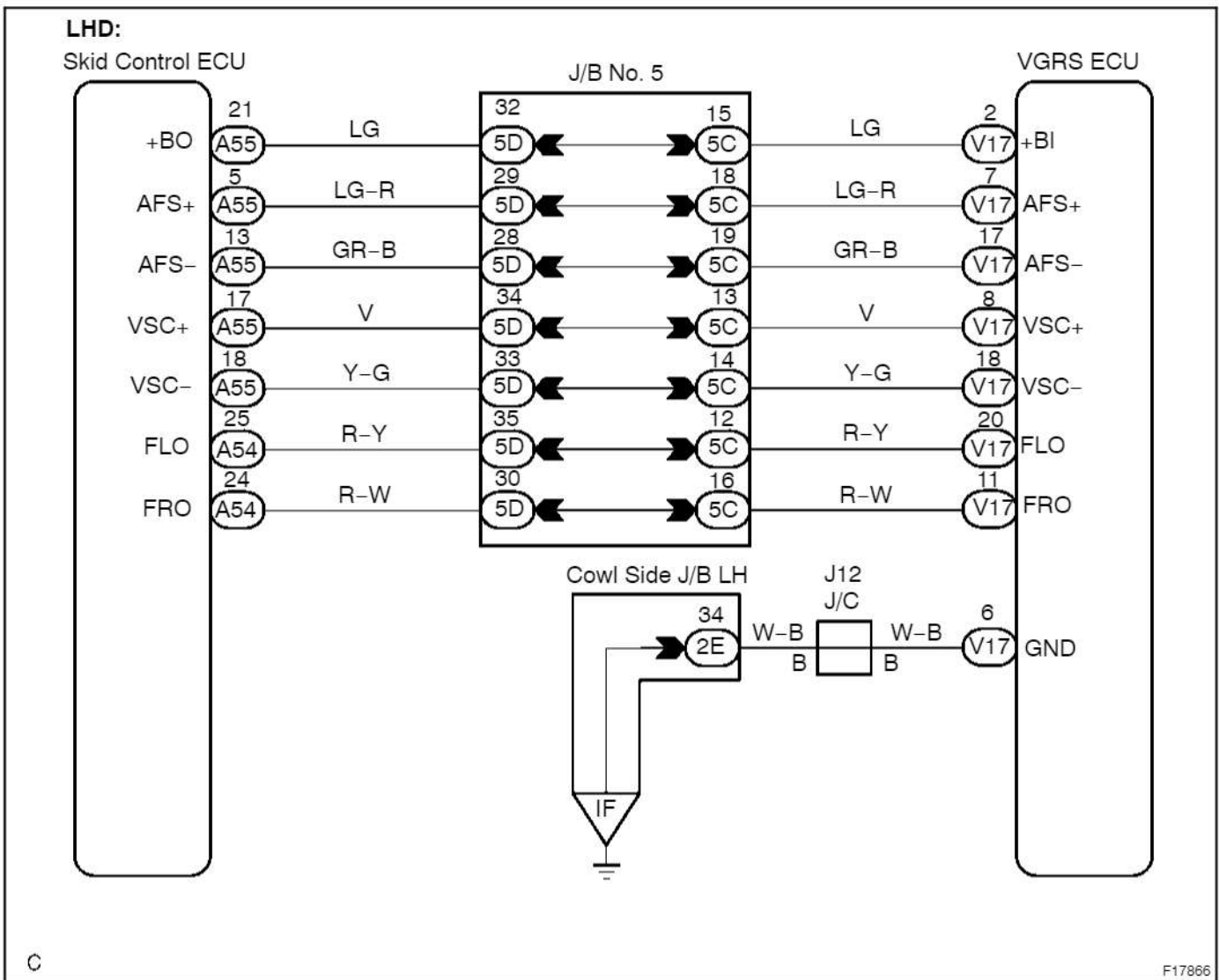

cardiagn.com

C

F17866

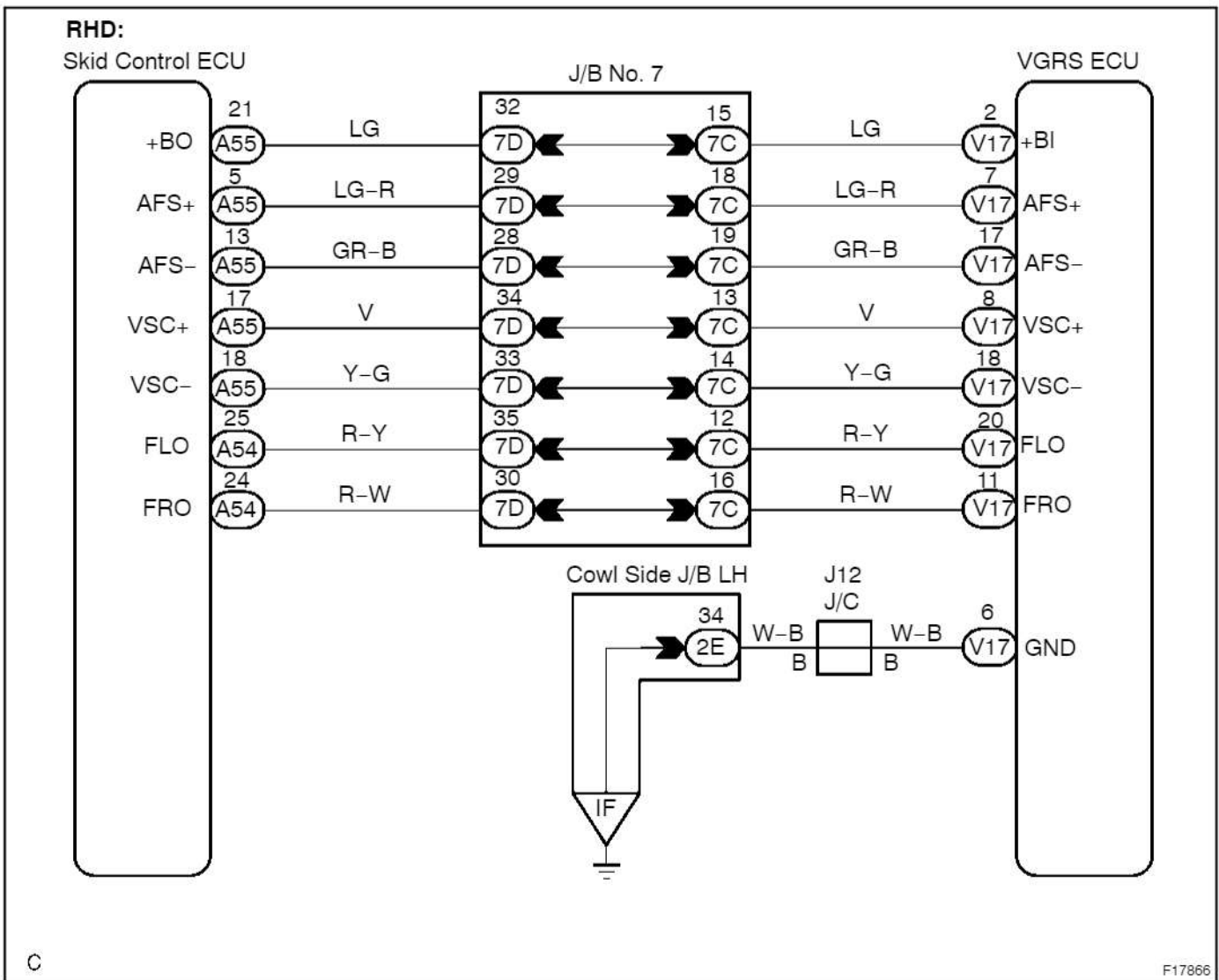

cardiagn.com

INSPECTION PROCEDURE

1 Check the signal waveform.

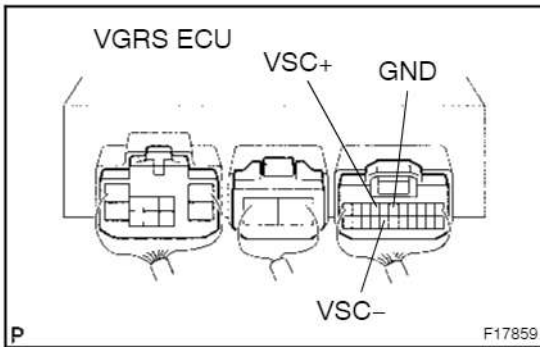
**PREPARATION:**

Start the engine.

CHECK:

- (a) Using an oscilloscope, check the waveform between VSC+ and GND of the VGRS ECU.

OK:**High and Low**

- (b) Using an oscilloscope, check the waveform between VSC- and GND of the VGRS ECU.

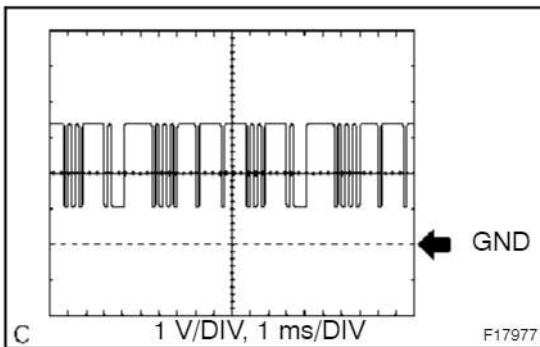
OK:**High and Low**

OK

Replace VGRS ECU.

NG

Proceed to step 2

- 2** Check for an open or short circuit in the harness and connector between terminals VSC+ and VSC- of the VGRS ECU, and between terminals VSC+ and VSC- of the skid control ECU (See page IN-38).

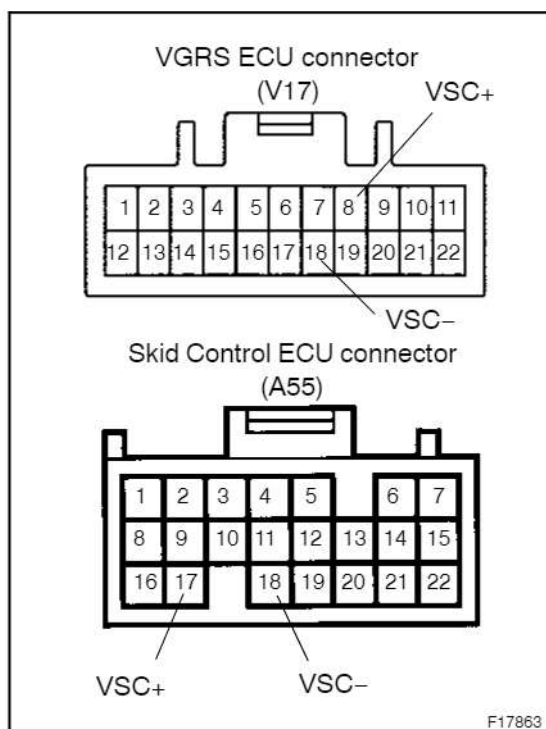
**PREPARATION:**

- Turn the ignition switch OFF.
- Disconnect the VGRS ECU connector (V17) and the skid control ECU connector (A55).

CHECK:

Check continuity between terminal VSC+ and VSC- of the VGRS ECU and skid control ECU.

OK:

Continuity

NG

Repair or replace harness and connector.

OK

- 3** Check for a short to ground in the VSC+ and VSC- circuit.

OK:

No short to ground.

NG

Repair or replace harness and connector.

OK

Replace skid control ECU.

DTC	C1551 / 51	IG Power Source Voltage Malfunction
------------	-------------------	--

CIRCUIT DESCRIPTION

The VGRS ECU monitors IG power supply voltage. If the ECU detects a malfunction, it turns on the warning light, records the DTC, and stops VGRS operation.

DTC No.	DTC Detecting Condition	Trouble Area
C1551/51	The system checks that the battery voltage is normal and the IG terminal voltage is less than 9 V for 6 sec.	<ul style="list-style-type: none"> • ECU-IG1 fuse • IG circuit • Charging system • VGRS ECU

WIRING DIAGRAM

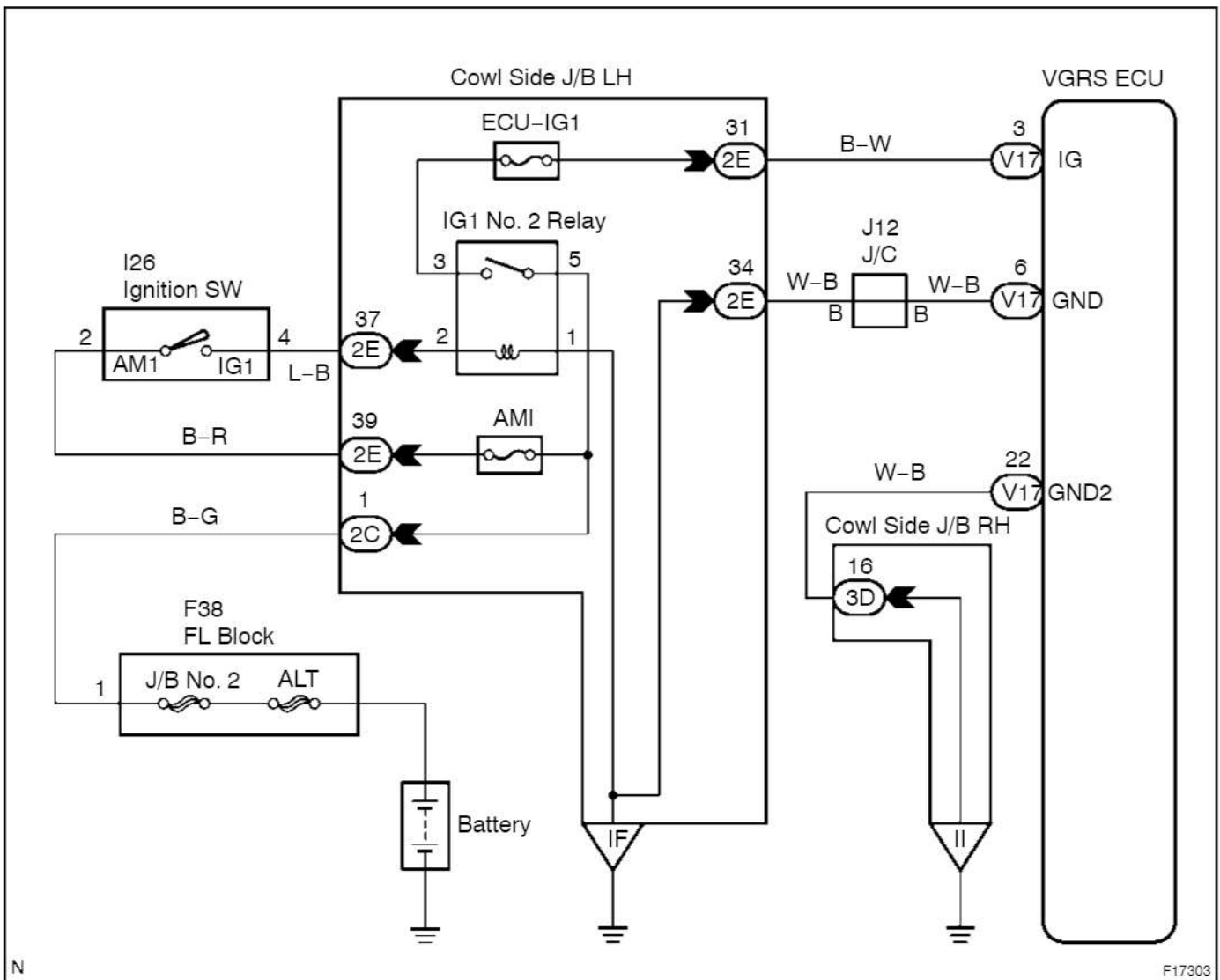

cardiagn.com

INSPECTION PROCEDURE

1 Check voltage between terminals IG and GND of the VGRS ECU connector.

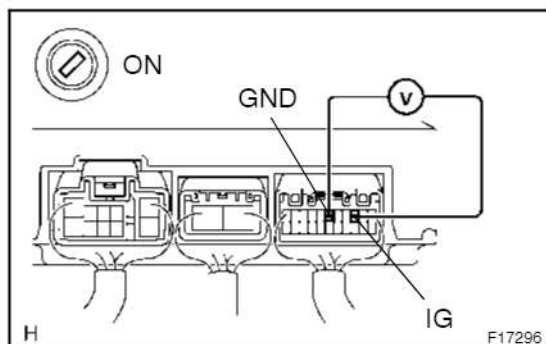
**PREPARATION:**

Record and clear VGRS DTCs.

CHECK:

Start the engine and measure the voltage between terminals IG and GND of the VGRS ECU.

A	9 to 16 V
B	Below 9 V
C	Above 16 V

B

Check or repair harness and ECU-IG1 fuse.

C

Check and repair charging system.

A

2 Check VGRS for DTC C1551/51.

Is DTC C1551/51 present?

YES

Replace VGRS ECU.

NG

No fault detected.

NOTICE:

Fault may be intermittent. Check harness and connectors carefully and retest.

DTC	C1552 / 52	DC Motor Power Source Voltage Malfunction
------------	-------------------	--

CIRCUIT DESCRIPTION

The VGRS ECU monitors PIG (motor power source voltage). If the ECU detects a malfunction, it turns on the warning light, records the DTC and stops VGRS operation.

DTC No.	DTC Detecting Condition	Trouble Area
C1552/52	The system checks that the IG voltage is 9 to 16 V, and the PIG terminal voltage is less than 6 V for 2.4 sec.	<ul style="list-style-type: none"> •VGRS Fuse •Power source circuit •VGRS ECU

WIRING DIAGRAM

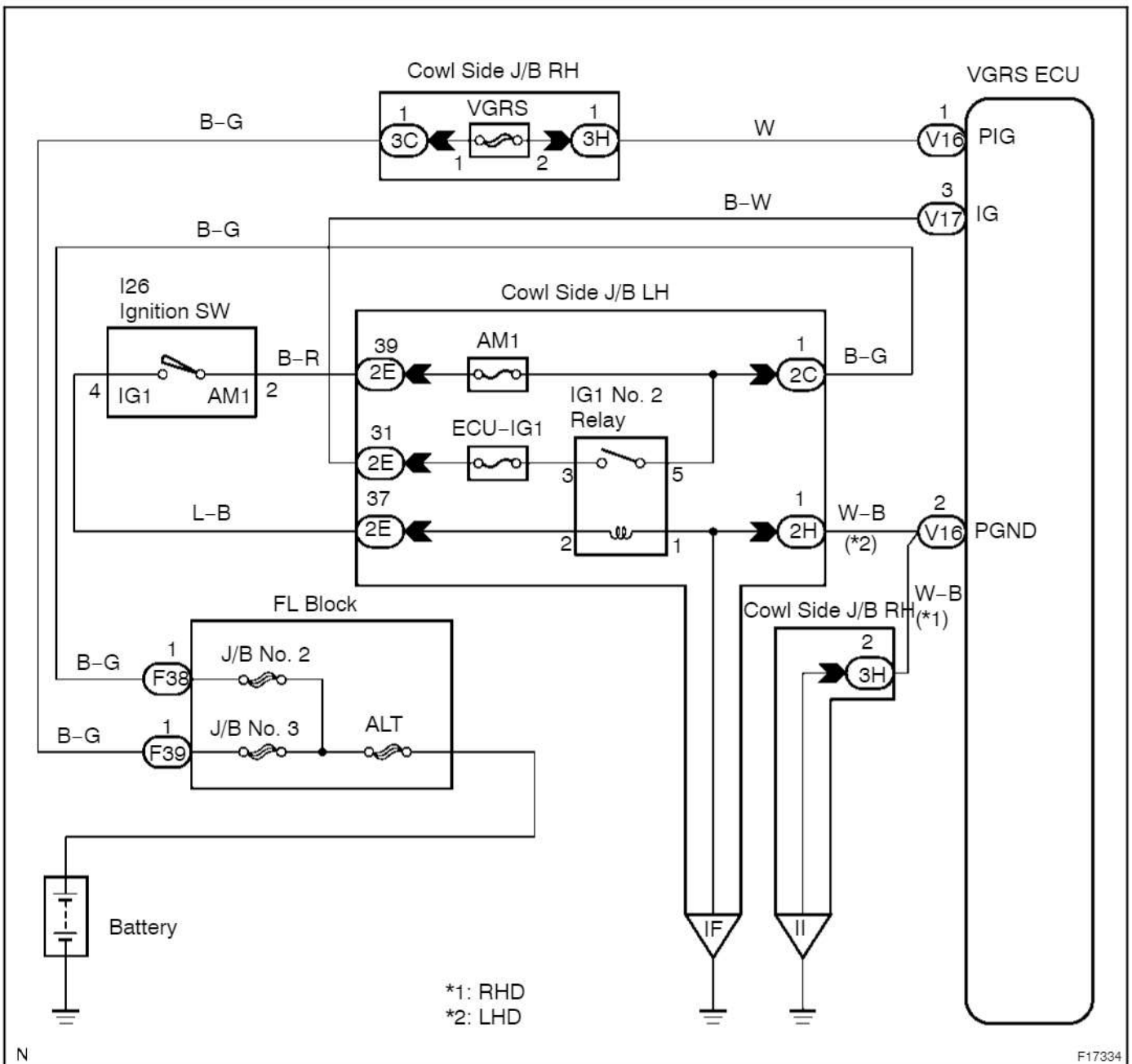

cardiagn.com

INSPECTION PROCEDURE

1 Check motor power source voltage (PIG).

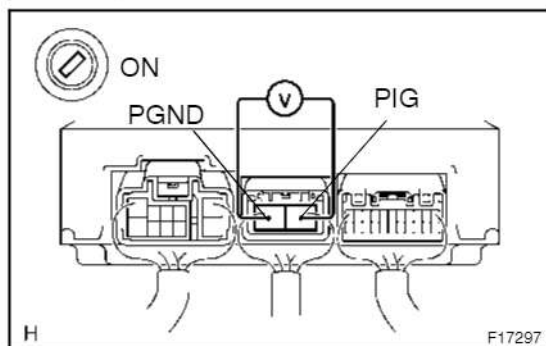
**PREPARATION:**

Record and clear VGRS DTCs.

CHECK:

Start the engine and measure the voltage between terminals PIG and PGND of the VGRS ECU.

A	9 to 16 V
B	Below 9 V
C	Above 16 V

B Check or repair harness and VGRS fuse.

C Check and repair charging system.

A

2 Check VGRS for DTC C1552/52.

Is DTC C1552/52 present?

YES Replace VGRS ECU.

NO

No fault detected.

NOTICE:

Fault may be intermittent. Check harness and connectors carefully and retest.

DTC	C1554 / 54	Power Source Relay Failure
------------	-------------------	-----------------------------------

CIRCUIT DESCRIPTION

When the VGRS ECU detects a malfunction in the power supply relay (located inside the VGRS ECU), the ECU turns on the warning light, records the DTC, and stops VGRS operation.

DTC No.	DTC Detecting Condition	Trouble Area
C1554/54	The system detects a malfunction of the power source relay or an open circuit.	<ul style="list-style-type: none"> •VGRS Fuse •VGRS ECU

WIRING DIAGRAM

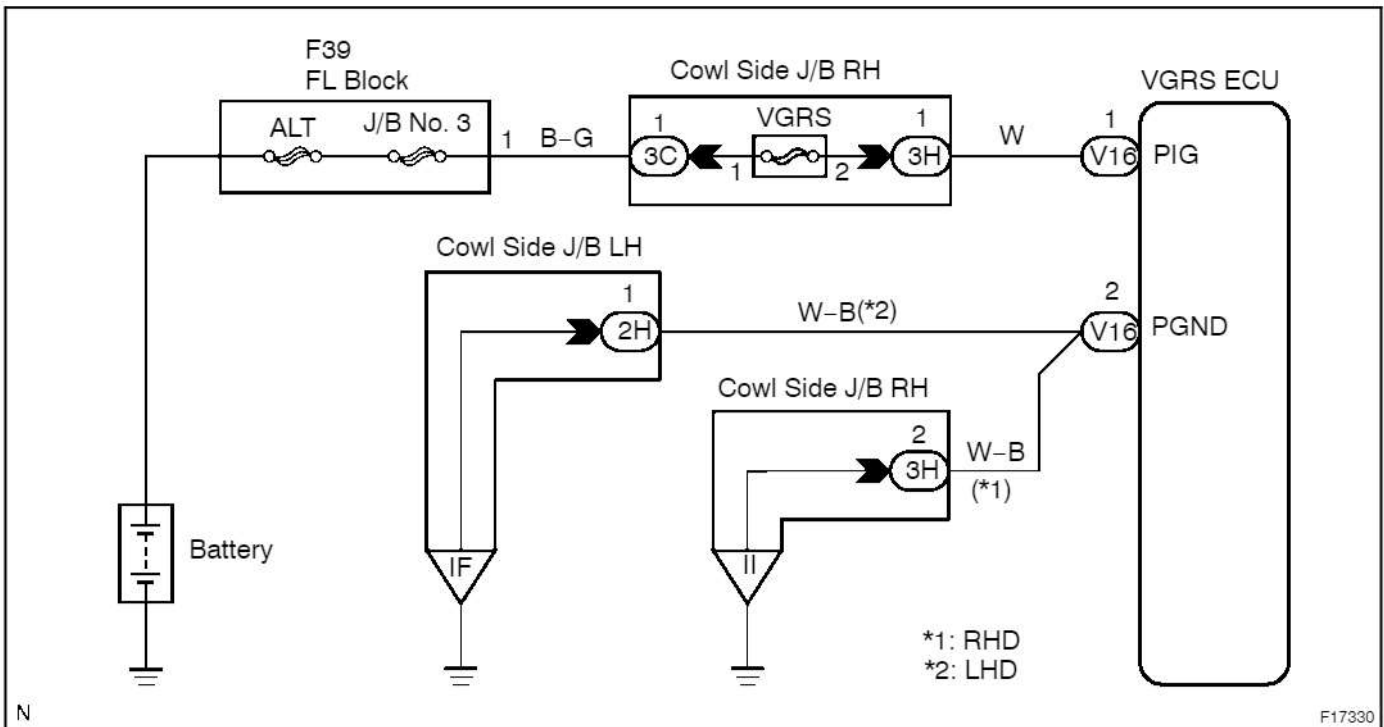

INSPECTION PROCEDURE

- 1 Check the voltage between terminals PIG and PGND of the VGRS ECU connector.

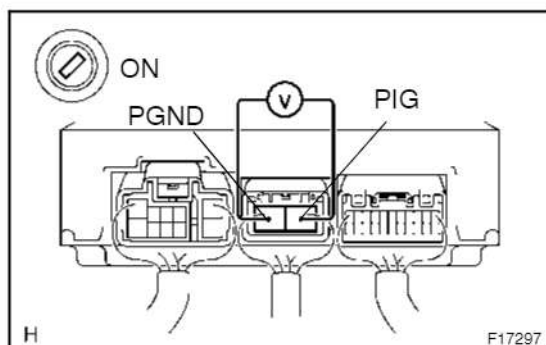
**PREPARATION:**

Record and clear VGRS DTCs.

CHECK:

Start the engine and measure the voltage between terminals PIG and PGND of VGRS ECU.

A	9 to 16 V
B	Below 9 V
C	Above 16 V

B Check and repair harness and VGRS fuse.

C Check and repair charging system.

A

- 2 Check VGRS for DTC C1554/54.

Is DTC C1551/54 present?

YES Replace VGRS ECU.

NG

No fault detected.

NOTICE:

Fault may be intermittent. Check harness and connectors carefully and retest.

DTC	C1555 / 55	Predriver Malfunction
------------	-------------------	------------------------------

CIRCUIT DESCRIPTION

When the VGRS ECU detects a malfunction in the predriver, it turns the warning light on and records the DTC at the same time, and then stops VGRS operation.

DTC No.	DTC Detecting Condition	Trouble Area
C1555/55	Even when the estimated value of the motor power source current is at least 10 A, the system detects that the actual motor power source current is less than 3 A for 0.1 sec.	<ul style="list-style-type: none"> • Power source circuit • VGRS ECU

WIRING DIAGRAM

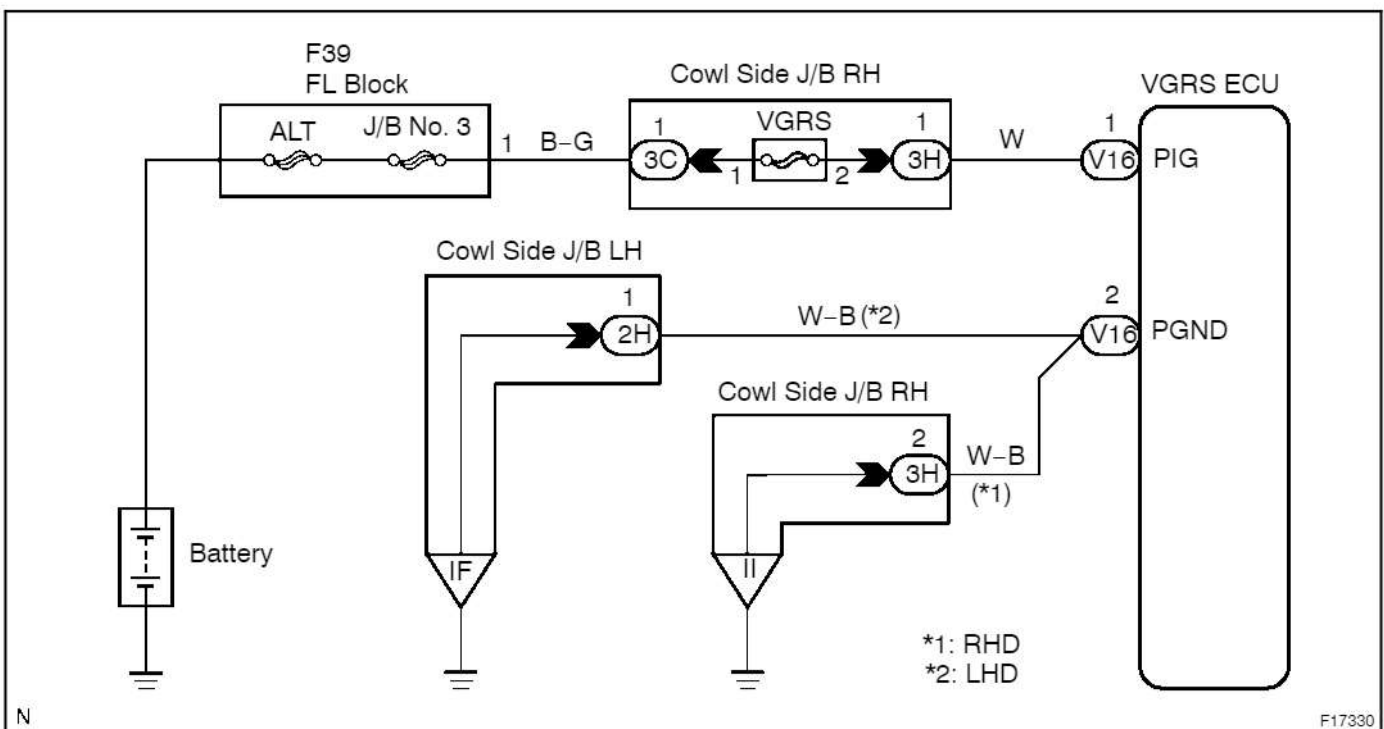

INSPECTION PROCEDURE

HINT:

After the procedure, perform the counter clearance (See page DI-106).

- | | |
|----------|---|
| 1 | Check for an open or short circuit in the harness and connector between terminal PGND of VGRS ECU and body ground. |
|----------|---|

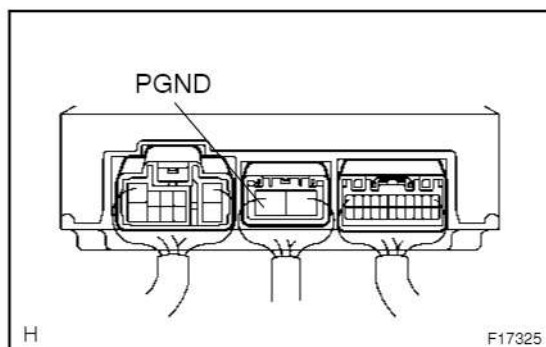

PREPARATION:

Turn the ignition switch OFF.

CHECK:

Check continuity between terminal PGND of VGRS ECU and body ground.

OK:

Less than 1 Ω

NG

Repair or replace harness and connector.

OK

- | | |
|----------|--------------------------------------|
| 2 | Check output of DTC C1522/22. |
|----------|--------------------------------------|

CHECK:

Turn the ignition switch ON and check the DTC (See page DI-91).

OK:

DTC C1522/22 is present

OK

Flow of DTC C1522/22.

NG

Replace VGRS ECU.

DTC	C1561 / 61	Lock Mechanism Malfunction
------------	-------------------	-----------------------------------

CIRCUIT DESCRIPTION

When the VGRS ECU detects a malfunction in the lock mechanism, it turns the warning light on, records the DTC, and stops VGRS operation.

DTC No.	DTC Detecting Condition	Trouble Area
C1561/61	The system detects that the LG terminal voltage is equal to battery voltage $\times 0.4 \pm 3$ V, or that the LG terminal voltage is outside the range of battery voltage $\times 0.6 \pm 3$ V for 1.2 sec.	<ul style="list-style-type: none"> •VGRS actuator •VGRS ECU

WIRING DIAGRAM

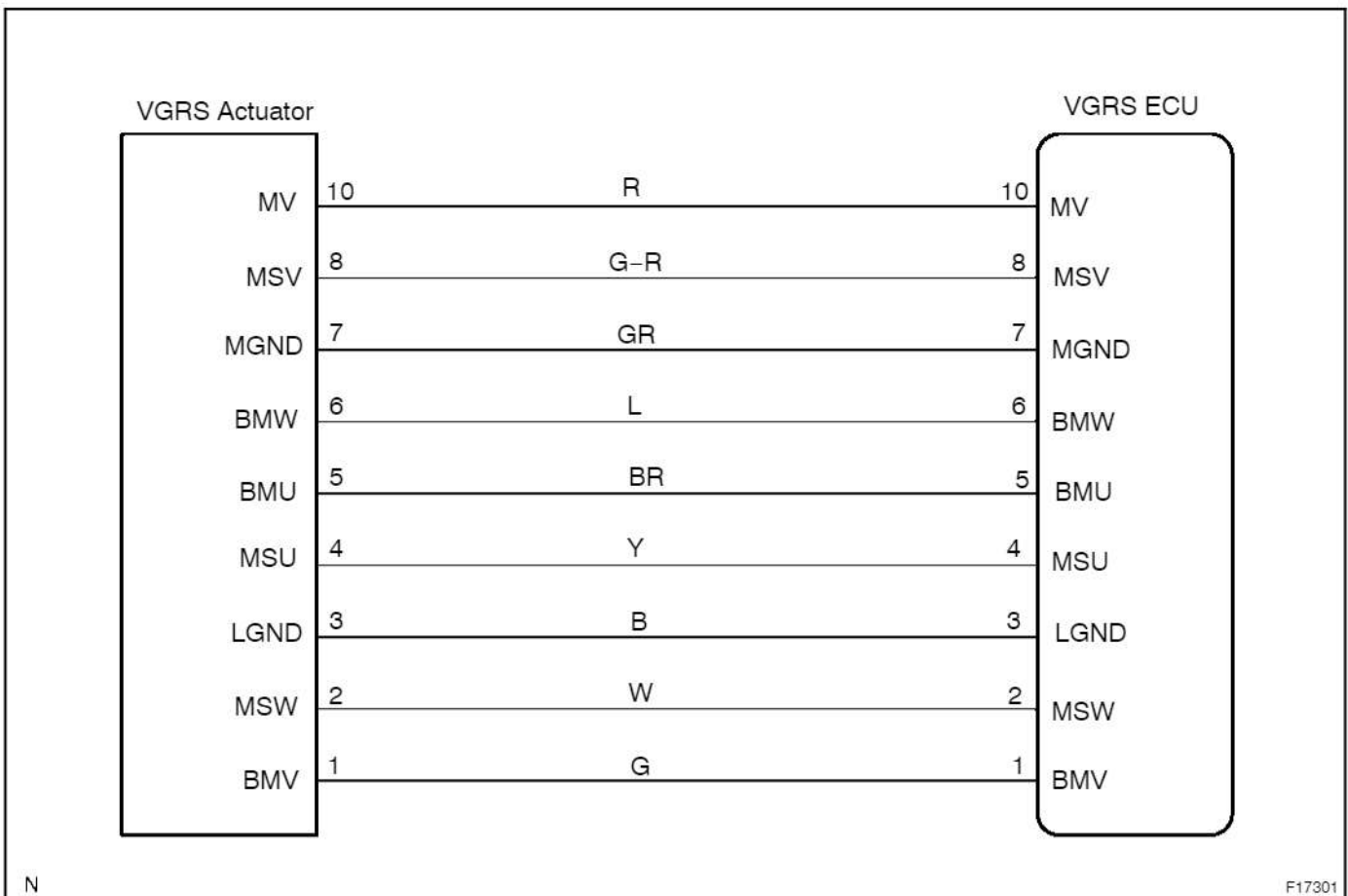

INSPECTION PROCEDURE

1 Check the position of the VGRS ECU connectors.

CHECK:

Check that VGRS ECU connectors are properly connected to the ECU.

OK:

Connection is good.

NG

DTC C1561/61 is detected because the connector is disconnected or is likely to be disconnected. Connect the connector correctly.

OK

2 Check for an open or short circuit in the harness and connector (See page [IN-38](#)).

PREPARATION:

- Turn the ignition switch OFF.
- Disconnect the VGRS ECU connector.

CHECK:

Measure resistance between terminals MV and LGND of the VGRS ECU connector.

OK:

1 to 100 Ω

CHECK:

Check continuity between terminals MV and LGND of the VGRS ECU and body ground.

OK:

No continuity

NG

Replace VGRS actuator.

OK

Replace VGRS ECU.

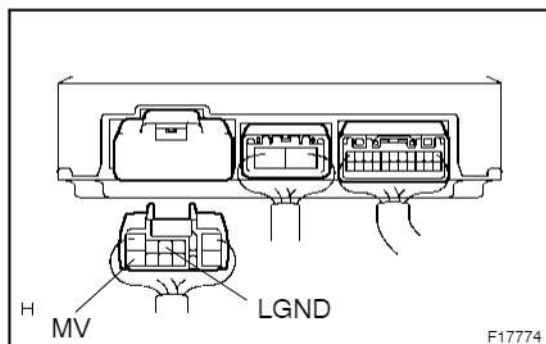

DTC	C1567 / 67	Lock Mechanism Insertion Malfunction
------------	-------------------	---

CIRCUIT DESCRIPTION

The VGRS actuator contains a lock mechanism that mechanically locks the DC motor so the motor will not rotate if a failure occurs or when the engine is not running. The VGRS ECU supplies current to the lock solenoid to release the lock lever for VGRS operation.

When the VGRS ECU detects a malfunction in the lock mechanism, it turns the warning light on and records the DTC.

DTC No.	DTC Detecting Condition	Trouble Area
C1567 / 67	The system detects a malfunction in the actuator system.	<ul style="list-style-type: none"> •VGRS actuator •VGRS ECU

INSPECTION PROCEDURE

When DTC C1567/67 is output, the VGRS is faulty. Replace the VGRS actuator.

1	Record and clear VGRS DTCs.
----------	------------------------------------



2	Observe VGRS warning light.
----------	------------------------------------

PREPARATION:

- (a) Turn the ignition switch OFF.
- (b) Start the engine.

CHECK:

Is the VGRS warning light ON?

NO	No fault detected.
-----------	---------------------------



Proceed to step 3.

3 Check VGRS for DTC C1567/67.

CHECK:

Is VGRS DTC C1567/67 present?

NO

Check other recorded DTCs.

YES

Replace VGRS actuator.

DTC	C1568 / 68	Lock Holder Deviation Detection
------------	-------------------	--

CIRCUIT DESCRIPTION

The VGRS actuator contains a lock mechanism that mechanically locks the DC motor so the motor will not rotate if a failure occurs or when the engine is not running. The VGRS ECU supplies current to the lock solenoid to release the lock lever for VGRS operation.

When the VGRS ECU detects a malfunction in the lock holder, it turns the warning light on and records the DTC.

DTC No.	DTC Detecting Condition	Trouble Area
C1568/68	The system detects a malfunction in the actuator lock system.	•VGRS actuator

INSPECTION PROCEDURE

HINT:

Determine the trouble area by checking the motor revolution angle sensor signal with hand-held tester. When not using hand-held tester, go to step 2.

1	Observe the data for MTR REV ANG U, V, W on the hand-held tester.
----------	--

PREPARATION:

- (a) Connect the hand-held tester to DLC3.
- (b) Turn the ignition switch ON. (Engine stop)
- (c) Turn the steering wheel to the right and left.
- (d) Using the hand-held tester, display the data list.

CHECK:

Check the motor revolution angle sensor signal when slowly turning the steering wheel referring to the data list.

OK:

A, B or C as shown below

	A		B		C	
	turn to left	turn to right	turn to left	turn to right	turn to left	turn to right
MTR REV ANG U	High	High	High	High	High	High
MTR REV ANG V	Low	Low	Low	Low	High	Low
MTR REV ANG W	Low	Low	Low	High	Low	Low

NG

Replace VGRS actuator.

OK

Perform VGRS system calibration
(See page DI-100).

2 Check the voltage motor revolution angle sensor signal.

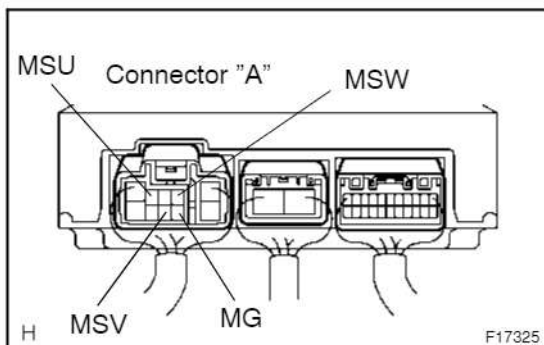

PREPARATION:

Turn the ignition switch ON.

CHECK:

Measure the voltage between terminals in the VGRS ECU while slowly turning the steering wheel.

OK:

A, B or C as shown below

	A		B		C	
	turn to left	turn to right	turn to left	turn to right	turn to left	turn to right
MSU (A4) - MG (A7)	Above 3.5 V	Above 3.5 V	Above 3.5 V	Above 3.5 V	Above 3.5 V	Above 3.5 V
MSV (A8) - MG (A7)	Below 1 V	Below 1 V	Below 1 V	Below 1 V	Above 3.5 V	Below 1 V
MSW (A2) - MG (A7)	Below 1 V	Below 1 V	Below 1 V	Above 3.5 V	Below 1 V	Below 1 V

NG

Replace VGRS actuator.

OK

Perform VGRS system calibration
(See page DI-100).

DTC	C1569 / 69	Lock Mechanism Release Incomplete
------------	-------------------	--

CIRCUIT DESCRIPTION

The VGRS actuator contains a lock mechanism that mechanically locks the DC motor so the motor will not rotate if a failure occurs or when the engine is not running. The VGRS ECU supplies current to the lock solenoid to release the lock lever for VGRS operation.

When the VGRS ECU detects a malfunction in the lock mechanism, it turns the warning light on and records the DTC.

DTC No.	DTC Detecting Condition	Trouble Area
C1569/69	The system cannot start controlling because the actuator lock is not released.	•VGRS actuator

INSPECTION PROCEDURE

1	Is the power steering operating normally? (The steering effort is not heavy.)
----------	--

NO

Perform power steering check, because DTC may have occurred due to a faulty power steering system (See page SR-3).

YES

2	Check VGRS operation.
----------	------------------------------

PREPARATION:

Start the engine.

CHECK:

Check the number of turns of the steering wheel from lock to lock.

A: Approx. 2.4 turns

B: More than 2.4 turns

B

Replace the VGRS actuator.

A

Proceed to step 3.

3 Check VGRS for DTC C1569/69.**PREPARATION:**

- (a) Record and clear DTCs.
- (b) Turn the ignition switch OFF.
- (c) Start the engine.

CHECK:

Is DTC C1569/69 present?

YES**Replace the VGRS actuator.****NO**

**No problem.
(Power steering may have caused the fault.)**

VGRS stops and does not operate. (It does not operate even when turning the ignition switch ON again)

INSPECTION PROCEDURE

After checking that the DTC of VGRS is normal, preform the following procedure.

1 Check MTR overheat on the VGRS Data List.

A: Rec (Record motor overheating)

B: Unrec (No record of motor overheating)

B

Go to step 3.

HINT:

Clear MTR overheat. Refer to Data List ([See page DI-91](#)).

A

2 Check heat protection of actuator.

PREPARATION:

- (a) Turn the ignition switch ON for 15 min.
- (b) After 15 min., start the engine and perform lock to lock steering slowly (Approx. 90°/sec.) 3 times.

CHECK:

Check number of turns from lock to lock.

A: 2.4 turns

B: 3.3 turns

A

VGRS is normal.

B

Proceed to step 3.

3	Check the steering effort.
----------	-----------------------------------

PREPARATION:

- (a) Turn the ignition switch ON and start the engine.
- (b) Perform the steering.

CHECK:

Check the steering effort.

OK:

Below 4.9 N·m (50 kgf·cm, 43 ft·lbf)

NG

Check and repair power steering system.

OK

4	Check for any abnormal noise and vibration in VGRS actuator.
----------	---

NG

Replace VGRS actuator.

OK

5	Check power and ground circuits to VGRS ECU (See page IN-38).
----------	--

NG

Repair or replace harness or connector.

OK

Replace VGRS ECU.

Steering wheel off-center

INSPECTION PROCEDURE

1 Check that there are no DTCs in VGRS, VSC and ABS.

A: No code is present

B: Code is present

B

Repair DTCs.

A

2 Perform the steering angle sensor initialization ([See page DI-99](#)).

Is the steering wheel centered?

YES

END

NO

3 Check the vehicle pull.

YES

Vehicle pulling diagnosis.

NO

4 Are the tires all the specified size?

NO

Install specified size tires.

YES

5 Check the air pressure of the tires.

NG

Adjust air pressure of the tires to the specified pressure.

OK

6 Check the wheel alignment.

Is the wheel alignment correct?

NO

Perform wheel alignment adjustment.

YES

7 Perform the VGRS system calibration (See page DI-100).

(a) Is the steering off center?

NO

END

YES

8 Perform the actuator angle initialization (See page DI-100).

(a) Is the steering off center?

NO

END

YES

9 Adjust the tie rod-end.

NEXT

10	Perform the actuator angle adjustment (See page DI-100).
----	--

NEXT

END

Steering angle is different from right to left

INSPECTION PROCEDURE

After checking that the DTC of VGRS is normal, perform the following procedure.

1 Check the steering wheel is in the center position.

NG

Go to other troubleshooting "Steering wheel off-center" (See page DI-162)

OK

2 Check the steering angle.

PREPARATION:

- Place the steering wheel straight ahead.
- Turn the ignition switch OFF.
- Disconnect the VGRS actuator connector from the VGRS ECU.
- Start the engine.

CHECK:

Check the rotating angle in the right and left direction when turning the steering wheel from lock to lock.

OK:

No difference

NOTICE:

When the ignition switch is ON with the steering actuator connector disconnected, DTC C1561/61 is stored. Clear this code after this check.

NG

Repair or replace power steering system (See page SR-3 and SR-20).

NOTICE:

After repairing or replacing the power steering system, perform VGRS system calibration.

OK

Go to other troubleshooting (See page DI-162 and DI-166).

Abnormal noise and vibration in the steering wheel

INSPECTION PROCEDURE

Check that the DTCs of VGRS, VSC and ABS are normal.

1	Check for abnormal noise and vibration when turning the steering wheel.
----------	--

PREPARATION:

- (a) Turn the ignition switch OFF.
- (b) Disconnect the VGRS actuator connector from VGRS ECU.

CHECK:

Check for abnormal noise and vibration, after starting the engine and turning the steering wheel.

OK:

No abnormal noise and vibration

NOTICE:

When the ignition switch is ON with the steering actuator connector disconnected, DTC C1561/61 is stored. Clear this code after this check.

NG

Check and repair power steering system.

OK

Replace VGRS actuator.

VGRS Warning Light Circuit

CIRCUIT DESCRIPTION

If the ECU detects a problem in the VGRS system, the VGRS warning light will illuminate, while at the same time prohibiting VGRS control and recording the DTC in memory.

Connect terminals Tc and CG of the DLC3 to make the VGRS warning light blink and output the DTC.

WIRING DIAGRAM

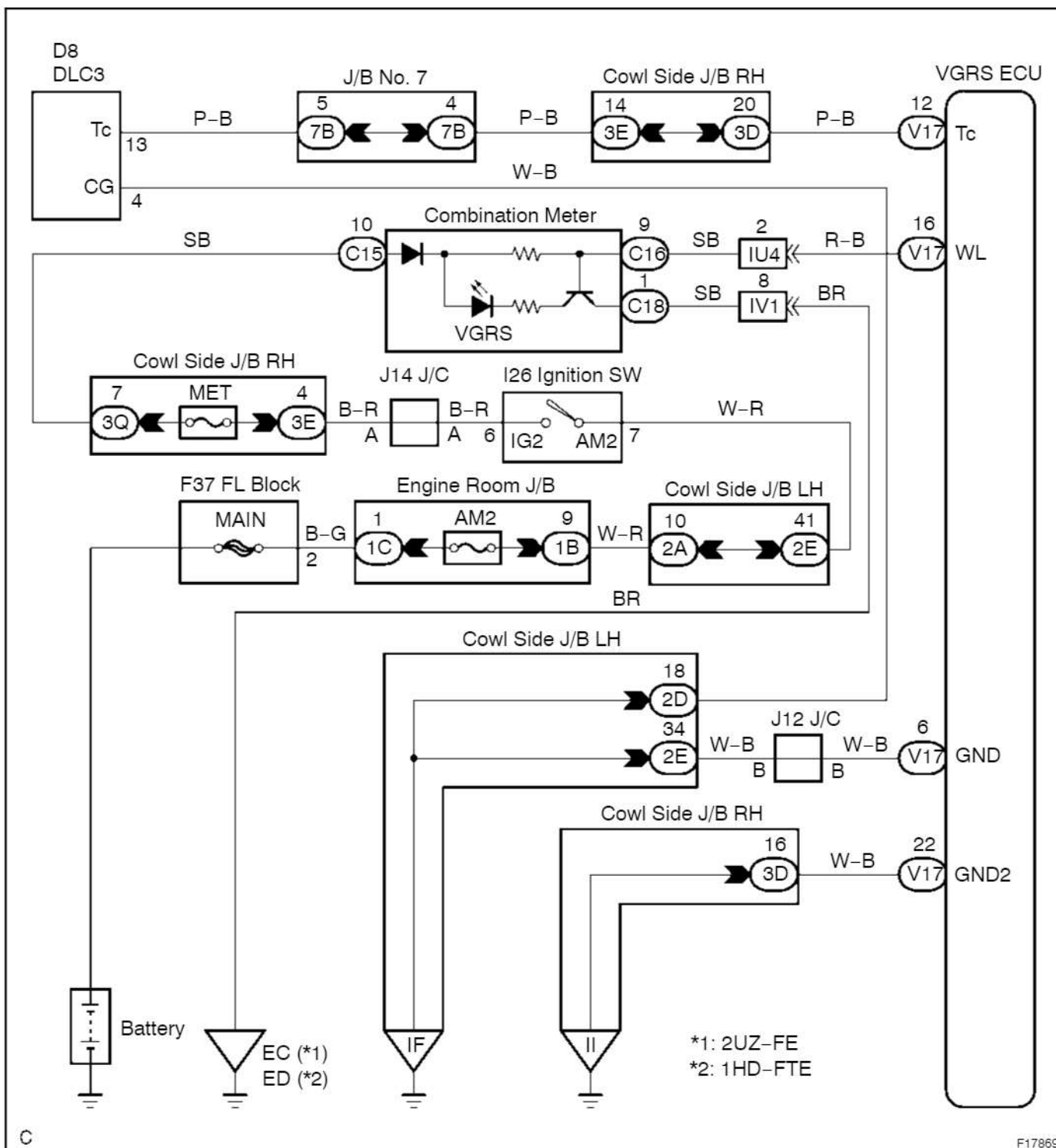

C

F17869

INSPECTION PROCEDURE

HINT:

Troubleshoot in accordance with the chart below for each trouble symptom.

VGRS warning light does not light up	Go to step 1
VGRS warning light remains on	Go to step 2

1	Connect terminals Tc and CG of DLC3 to make the warning light blink and output a DTC or normal code.
----------	---

A: VGRS warning light does not illuminate.

B: VGRS warning light remains on.

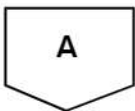
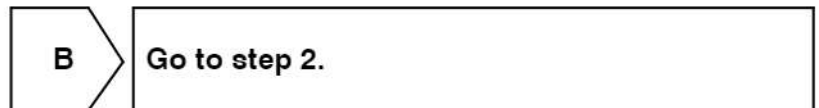

Check and repair circuit fuse, bulb, wire harness or combination meter.
--

2	Check for an open circuit between combination meter and VGRS ECU.
----------	--

A: Open circuit

B: No open circuit



Repair circuit.

Tc and CG Terminal Circuit

CIRCUIT DESCRIPTION

Connecting terminals Tc and CG of the DLC3 causes the VGRS ECU to display the DTC by blinking the VGRS warning light.

WIRING DIAGRAM

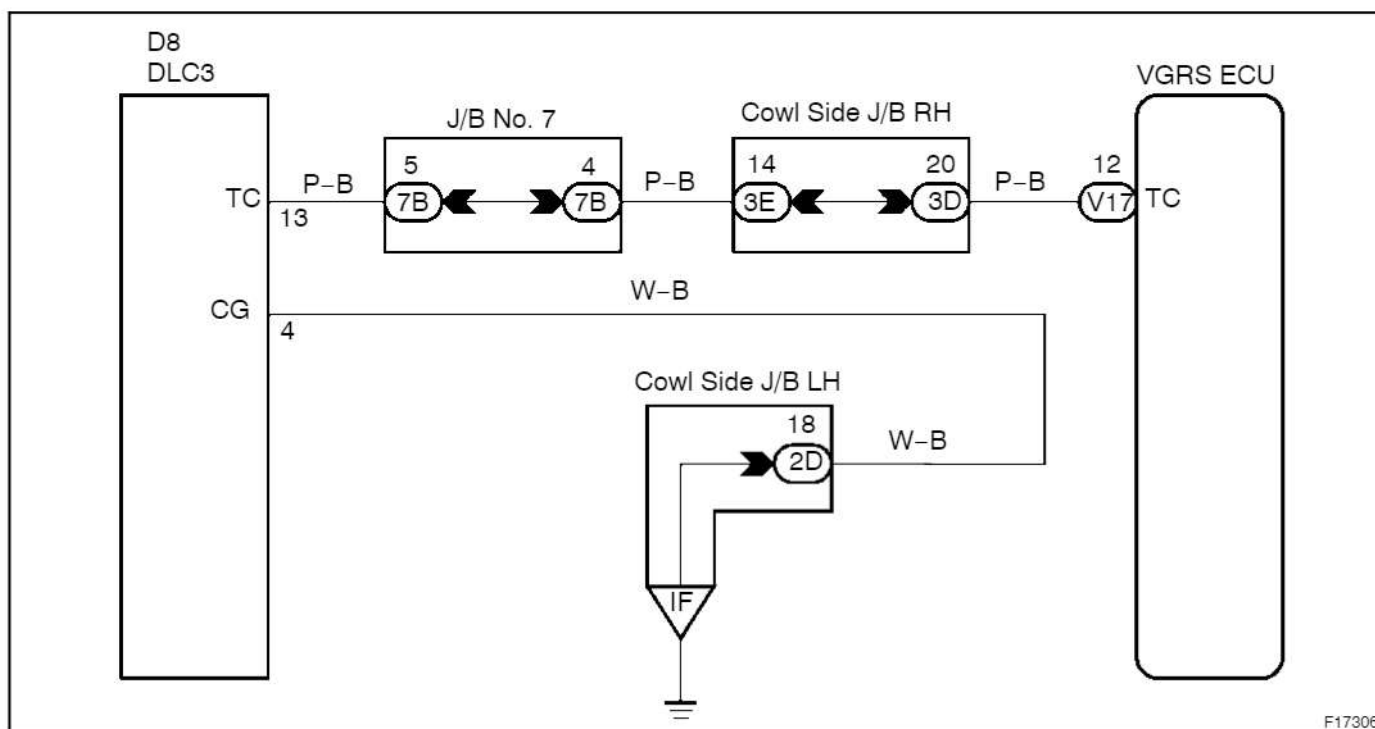

INSPECTION PROCEDURE

- 1 Check voltage between terminals Tc and CG of DLC3.

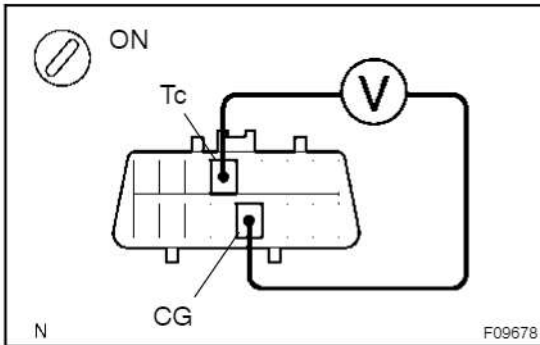
**CHECK:**

Turn the ignition switch ON and measure the voltage between terminals Tc and CG of the DLC3.

OK:

Voltage: 10 to 14 V

OK

If VGRS warning light does not blink even after Tc and CG are connected, check VGRS warning light circuit.

NG

- 2 Check for an open or short circuit in harness and connector between VGRS ECU and DLC3 (Tc), and DLC3 (CG) and body ground (See page IN-38).

NG

Repair or replace harness or connector.

OK

Replace VGRS ECU.

Ts and CG Terminal Circuit

CIRCUIT DESCRIPTION

The sensor signal check detects faults in VGRS sensor signal, which cannot be detected by the DTC check.

HINT:

If a current DTC exists when connecting Ts and CG, the warning light will remain on.

WIRING DIAGRAM

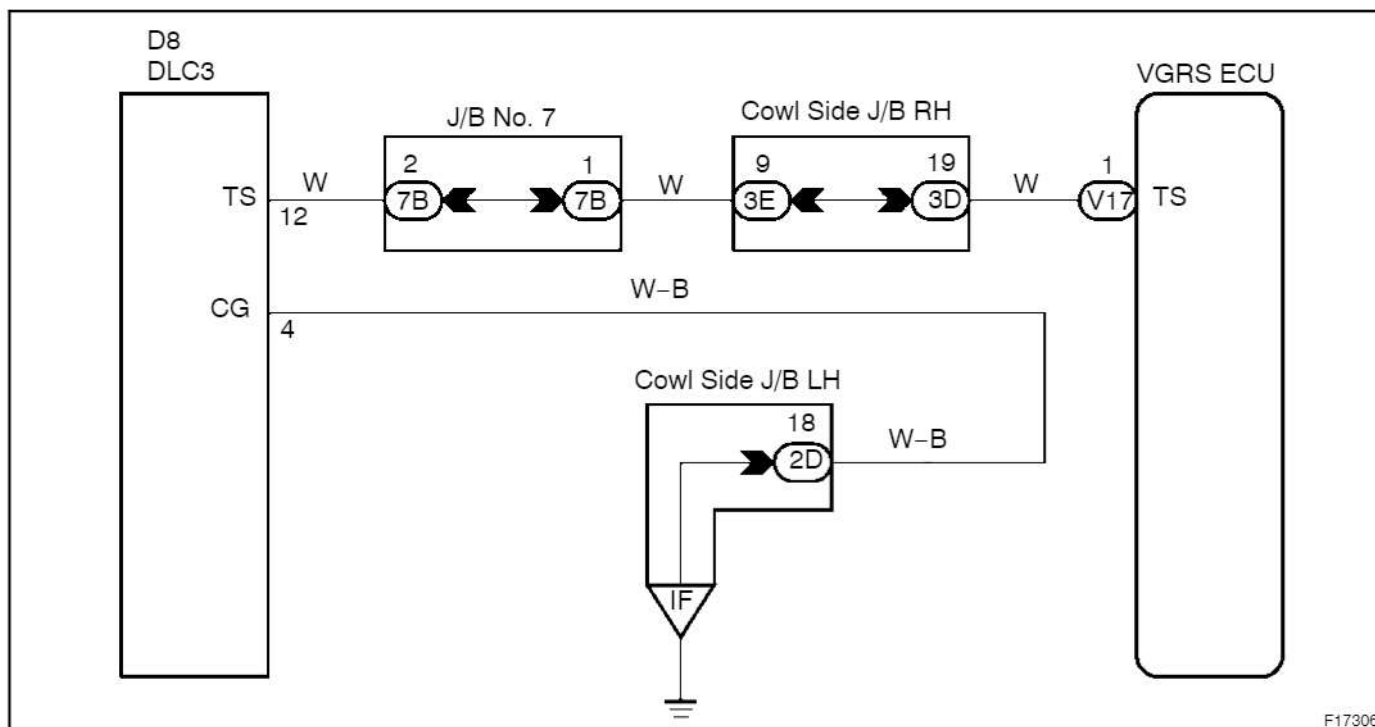

F17306

INSPECTION PROCEDURE

HINT:

Troubleshoot in accordance with the chart below for each trouble symptom.

VGRS warning light does not light up	Go to step 1
VGRS warning light remains on	Go to step 2

1	Connect terminals Ts and CG of DLC3.
----------	---

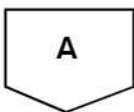
A: VGRS warning light does not illuminate.**B: VGRS warning light remains on.**

Check and repair circuit fuse, bulb, wire harness or combination meter.
--

2	Check for an open circuit between DLC3 (Ts) and VGRS ECU.
----------	--

A: Open circuit**B: No open circuit**

Repair circuit.

NAVIGATION SYSTEM

HOW TO PROCEED WITH TROUBLESHOOTING

DI27W-17

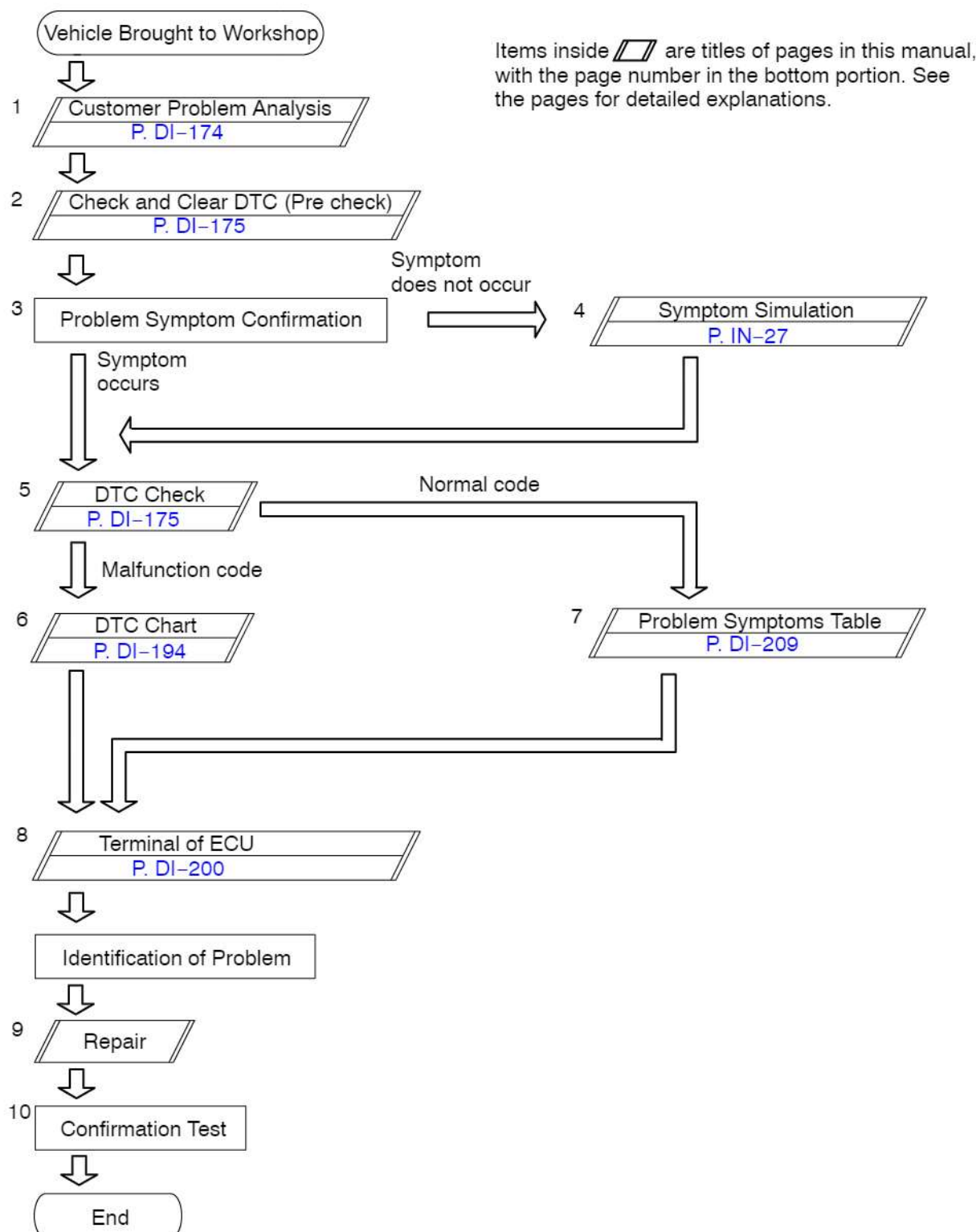

CUSTOMER PROBLEM ANALYSIS CHECK

NAVIGATION SYSTEM Check Sheet

Inspector's name: _____

Customer's Name		VIN	
		Production Date	
		Licence Plate No.	
Date of Vehicle Brought in	/ /	Odometer Reading	km mile

Date Problem First Occurred	/ /
Frequency Problem Occurs	<input type="checkbox"/> Constant <input type="checkbox"/> Intermittent (Times a day)

Problem Symptom	Navigation malfunction	<input type="checkbox"/> Cursor movement is defective.
		<input type="checkbox"/> Cursor does not move.
		<input type="checkbox"/> GPS mark does not appear.
		<input type="checkbox"/> Map is not displayed.
		<input type="checkbox"/> Others ()
	Display malfunction	<input type="checkbox"/> Screen is dark.
		<input type="checkbox"/> Screen is white.
		<input type="checkbox"/> Color is not uniform.
		<input type="checkbox"/> Screen is in disorder.
		<input type="checkbox"/> Others ()
	Control Switch malfunction	<input type="checkbox"/> Can not operate with panel switches.
		<input type="checkbox"/> Can not operate with touch switches.
		<input type="checkbox"/> Others ()

	Parts name	1st time malfunction code.	2nd time malfunction code.
DTC Check	NAVI (Navigation ECU)		
	EMV (Multi-display)		
	AUDIO H/U (Radio receiver)		
	G/W (Gateway ECU)		
	CD-CH		

PRE-CHECK

1. DIAGNOSTIC START-UP/FINISH

HINT:

- The illustrations may differ depending on the device settings (option, etc.). Therefore, some detailed areas may not be shown exactly same as on the actual vehicle.
 - After the ignition switch is turned on, check that the map is displayed before starting the diagnostic mode. Otherwise, some items cannot be checked.
- (a) There are 2 methods to start diagnostic mode. Start the mode by using one of them.

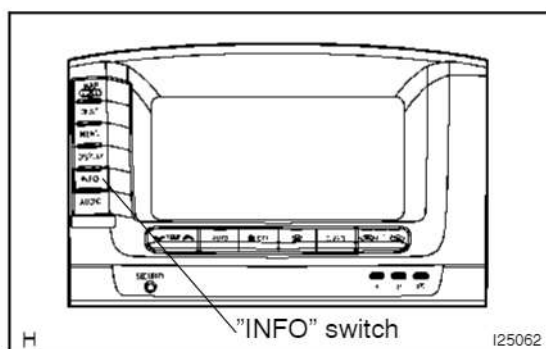

(b) Method 1

- (1) Start the engine.
- (2) While pressing and holding "INFO" switch, operate "TAIL" switch, OFF → TAIL → OFF → TAIL → OFF → TAIL → OFF.
- (3) The diagnostic mode starts and "Service Check" screen will be displayed. Service inspection starts automatically and the result will be displayed.

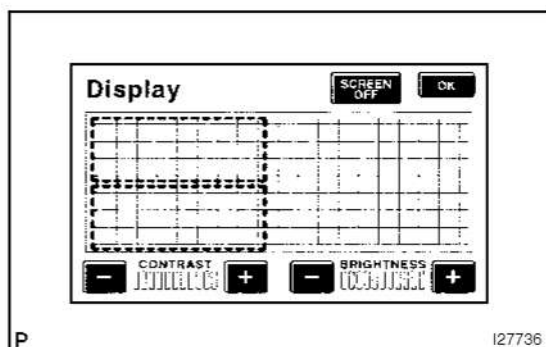

(c) Method 2

- (1) Start the engine.
- (2) Switch to the "Display Check" screen.
- (3) From the display adjustment screen, touch the corners of the screen in the following order: upper left → lower left → upper left → lower left → upper left → lower left.
- (4) The diagnostic mode starts and "Service Check" screen will be displayed. Service inspection starts automatically and the result will be displayed.

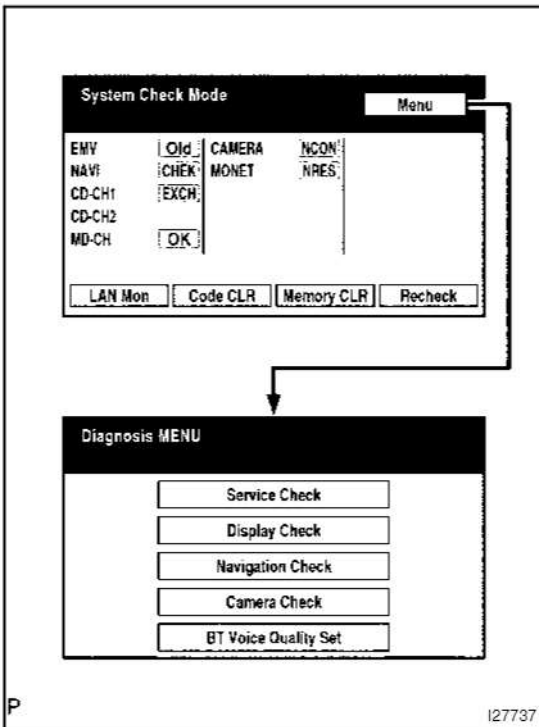

- (d) **Diagnosis MENU**
Pressing the menu switch on the service check screen, diagnostic window will be displayed.
- (e) There are 2 methods to exit. Use one of them.
(1) Turn the ignition switch off.
(2) Press the "Display" switch for 3 seconds.

2. SYSTEM CHECK MODE (DTC CHECK)

HINT:

The illustrations may differ depending on the device settings (option, etc.). Therefore, some detailed areas, may not be shown exactly same as on the actual vehicle.

- (a) Start the diagnostic mode.

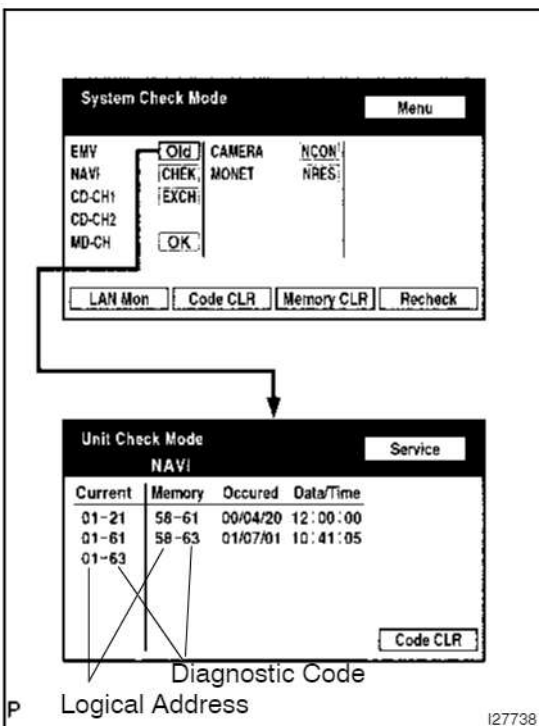

- (b) Read the service check result.
If all devices report is "EXCH", "CHEK" or "Old" touch the display to check the contents on the "Unit Check Mode" screen and fill them on the customer problem analysis check sheet.

HINT:

- If all check results are "OK" go to communication DTC check (Go to step 3).
- If a device name is not known, its physical address is displayed.

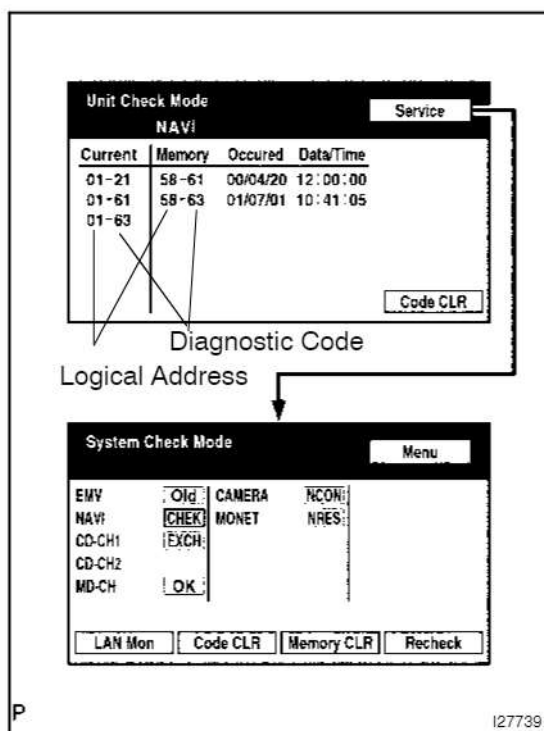

HINT:

If "EXCH", "CHEK" and "Old" as well as "OK" exist, press the service switch to return to the "System Check Mode". Then, check the "Unit Check Mode" screen and fill them in on the customer problem analysis check sheet.

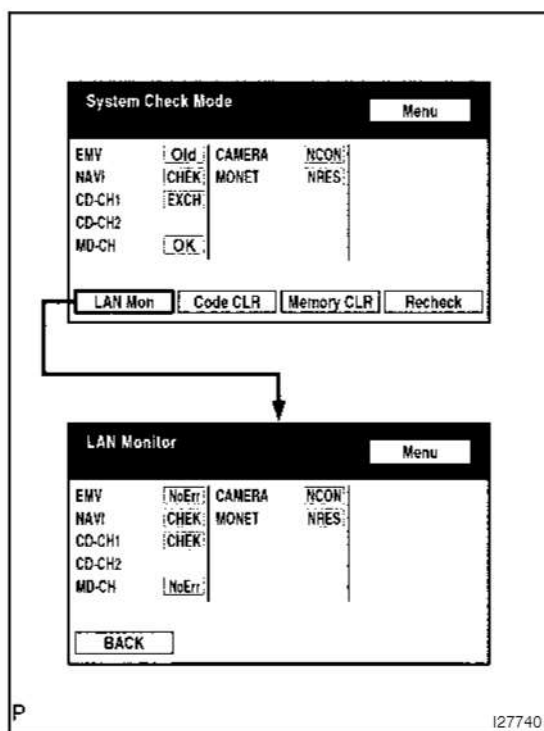

(c) Read the communication diagnostic check result.

- (1) Return to the "System Check Mode", and press "LAN Mon" switch to enter the LAN monitor window.

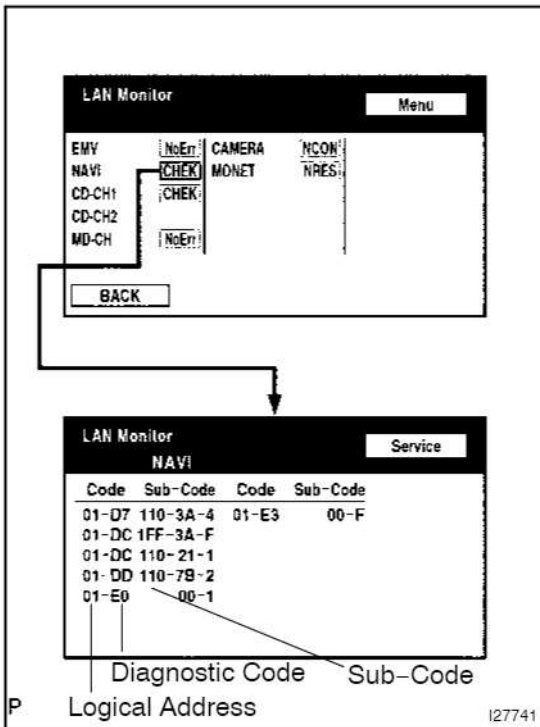

- (2) If the result is "CHEK" or "Old" touch this display to check the contents on the "Unit Check Mode" screen and fill them in on the customer problem analysis check sheet.

HINT:

- If all check results are "No Err" the system judges that no DTC exists.
- The sub-code (relevant device) will be indicated by its physical address.

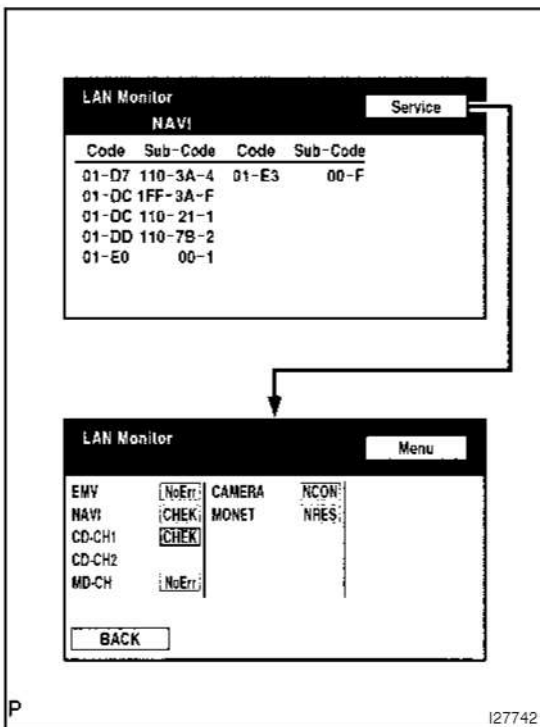

HINT:

If other devices return "CHEK" press the "Service" switch to return to the "LAN Monitor" screen. Then, check the individual communication diagnostic screen for the next device and fill out the result on the customer problem analysis check sheet.

3. SERVICE CHECK MODE (DTC CLEAR/RECHECK)

HINT:

The illustrations may differ from the actual vehicle depending on the device settings and options.

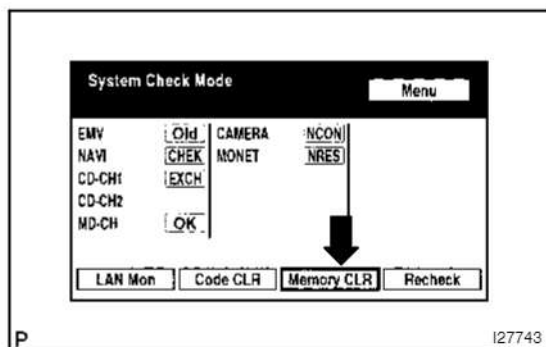

- (a) Clear DTC
 (1) Press "Memory CLR" switch for 3 seconds.

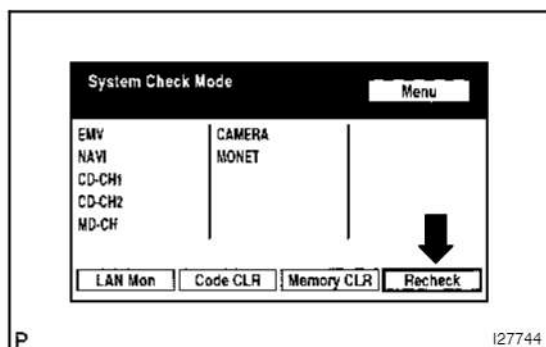

- (2) Check result is cleared.
 (b) Recheck
 (1) Press the "Recheck" switch.

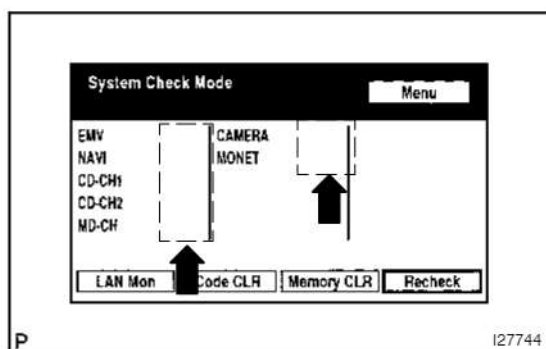

- (2) Confirm that all diagnostic codes are "OK" when the check results are displayed.
 If a code other than "OK" is displayed, troubleshoot again.

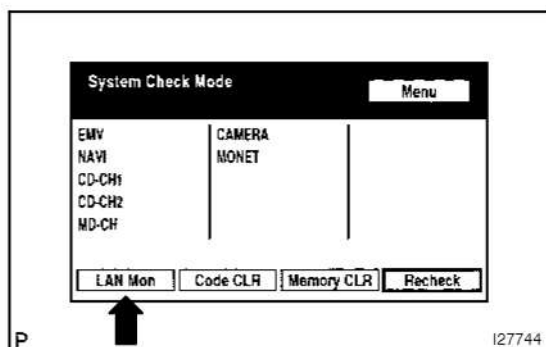

- (3) Press "LAN Mon" to switch to "LAN Monitor" mode.

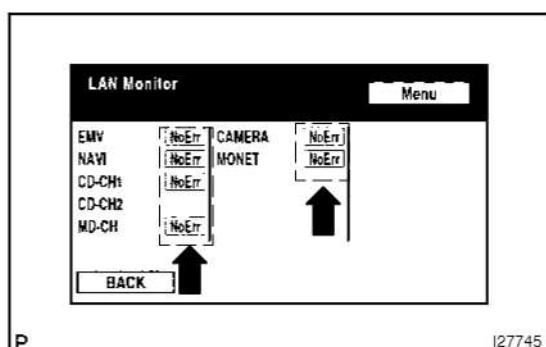

- (4) Confirm that all diagnostic codes are "No Err".
 If a code other than "No Err" is displayed, troubleshoot again.

4. DISPLAY CHECK MODE (TOUCH SWITCH CHECK)**HINT:**

- This mode checks the touch switch operation condition on the multi-display.
- Illustrations may differ from the actual vehicle depending on the device settings and options. Therefore, some detailed areas may not be shown exactly the same as on the actual vehicle.

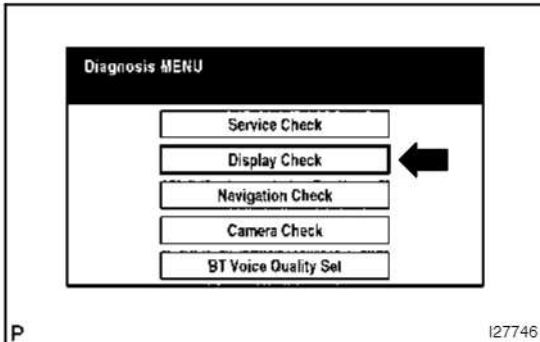

- (a) Select "Display Check" from the "Diagnosis MENU" screen.

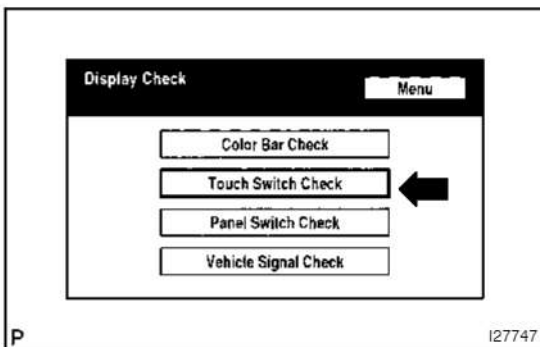

- (b) Select "Touch Switch Check" from the "Display Check" screen.

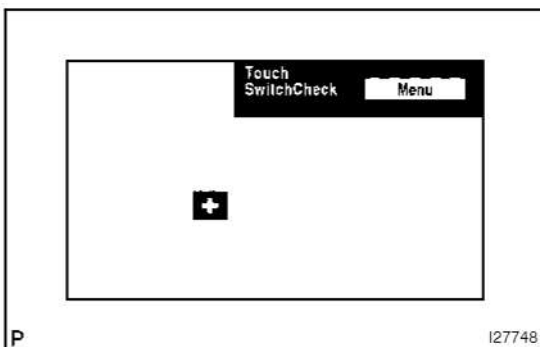

- (c) Touch the display anywhere in the open area to perform the check when the "Touch Switch Check" screen is displayed.

HINT:

- A "+" mark is displayed where the display is touched.
- The "+" mark remains on the display even after the finger is removed.

5. DISPLAY CHECK MODE (PANEL SWITCH CHECK)**HINT:**

- This mode checks the panel switch operation response on the multi-display.
- Illustrations may differ from the actual vehicle depending on the device settings and options. Therefore, some detailed areas may not be shown exactly the same as on the actual vehicle.

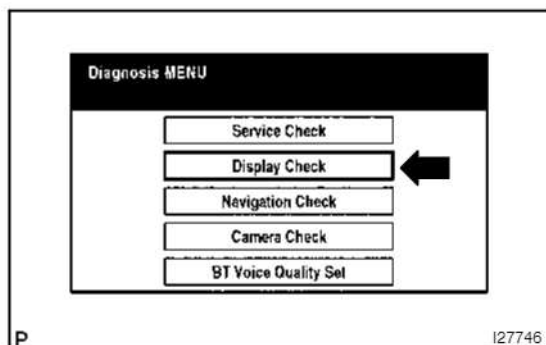

- (a) Select "Display Check" from the "Diagnosis MENU" screen.

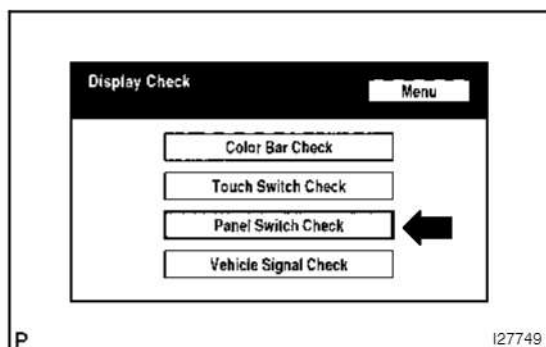

- (b) Select "Panel Switch Check" from the "Display Check" screen.

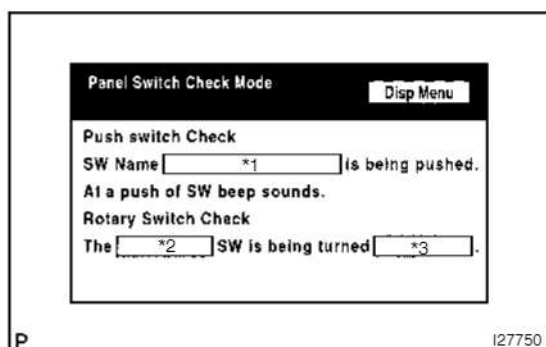

- (c) Operate each switch and check that the switch name and condition are correctly displayed.

HINT:

Pressing the "DISPLAY" switch for 3 seconds will exit the diagnostic mode.

Display	Contents
Push switch name/*1	<ul style="list-style-type: none"> Name of the pressed switch is displayed. If more than one switch is pressed, "MULTIPLE" is displayed.
Rotary switch name/*2	Name of the rotary switch is displayed.
Rotary switch direction/*3	Direction of the rotary switch is rotated.

6. DISPLAY CHECK MODE (VEHICLE SIGNAL CHECK)

HINT:

- This mode checks the vehicle signal status input to the multi-display.
- Illustrations may differ from the actual vehicle depending on the device settings and options. Therefore, some detailed areas may not be shown exactly the same as on the actual vehicle.

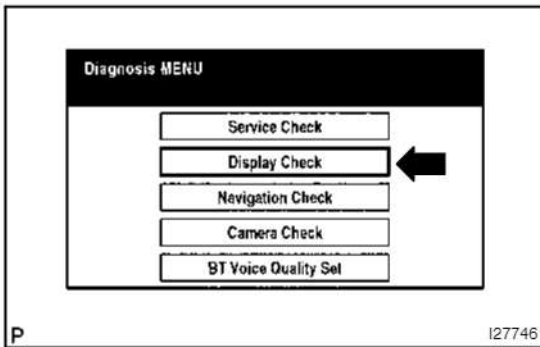

- (a) Select "Display Check" from the "Diagnosis MENU" screen.

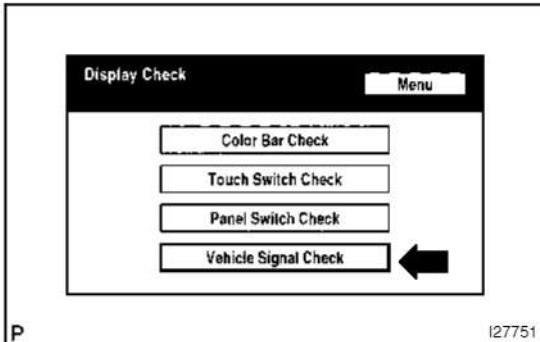

- (b) Select "Vehicle Signal Check" from the "Display Check" screen.

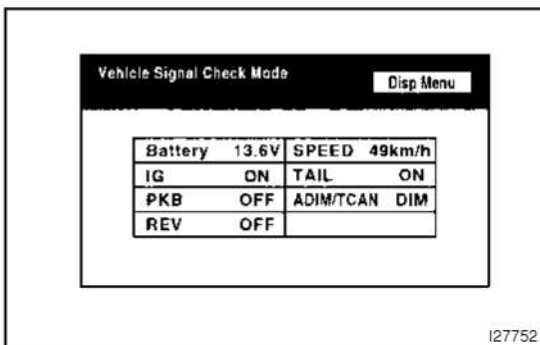

- (c) When the "Vehicle Signal Check Mode" screen is displayed, check all the vehicle signal conditions.

7. NAVIGATION CHECK MODE (VEHILCE SENSORS)

HINT:

- This mode checks the vehicle signal status to the navigation ECU.
- Illustrations may differ from the actual vehicle depending on the device settings and options. Therefore, some detailed areas may not be shown exactly the same as on the actual vehicle.

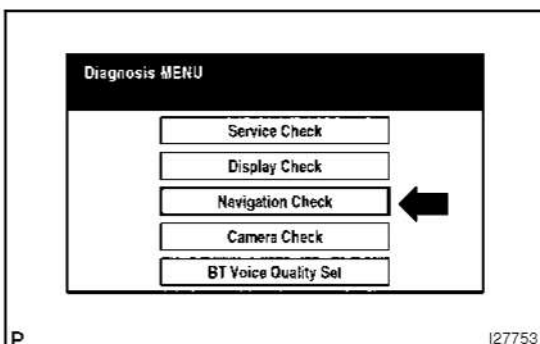

- (a) Select "Navigation Check" from the "Diagnosis MENU" screen.

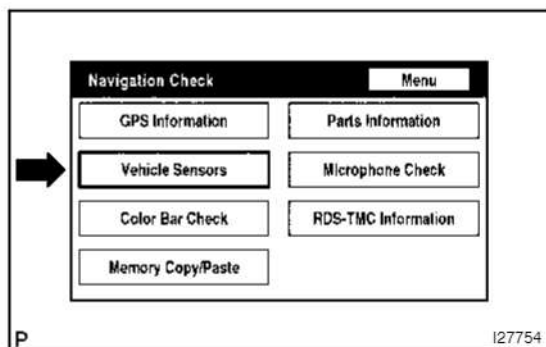

- (b) Select "Vehicle Sensors" from the "Navigation Check" screen.

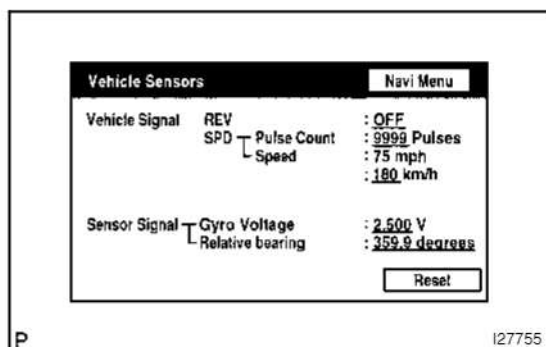

- (c) Check all the signals and sensors when vehicle signal information is displayed.

HINT:

This screen is updated once per second when input signals to the vehicle are changed.

8. NAVIGATION CHECK MODE (NAVI COLOR VAR CHECK)

HINT:

- This mode checks the color display on the navigation ECU.
- Illustrations may differ from the actual vehicle depending on the device settings and options. Therefore, some detailed areas may not be shown exactly the same as on the actual vehicle.

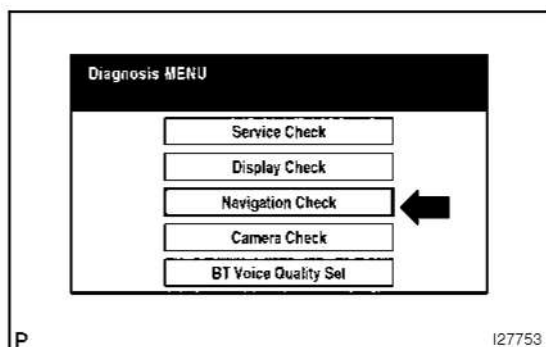

- (a) Select "Navigation Check" from the "Diagnosis MENU" screen.

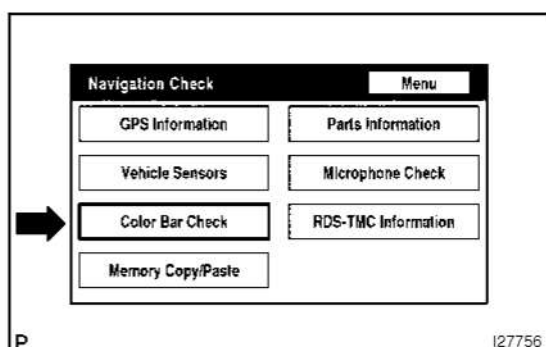

- (b) Select "Color Bar Check" from the "Navigation Check" screen.

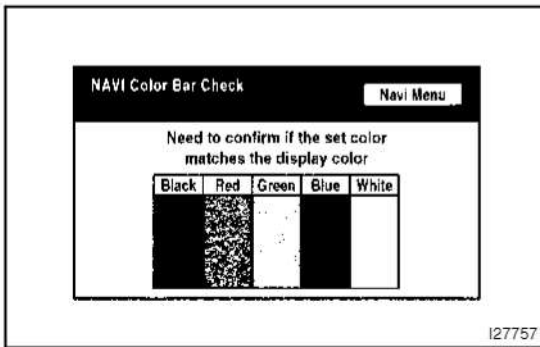

- (c) Check each color of the color bar when the "NAVI Color Bar Check" screen is displayed.

HINT:

Colors will not be displayed full-screen as in "Display Check Mode".

9. NAVIGATION CHECK MODE (PARTS INFORMATION)

HINT:

- This mode displays product information on the navigation systems and discs.
- Illustrations may differ from the actual vehicle depending on the device settings and options. Therefore, some detailed areas may not be shown exactly the same as on the actual vehicle.

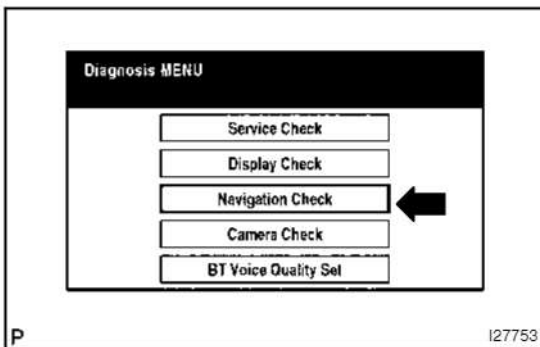

- (a) Select "Navigation Check" from the "Diagnosis MENU" screen.

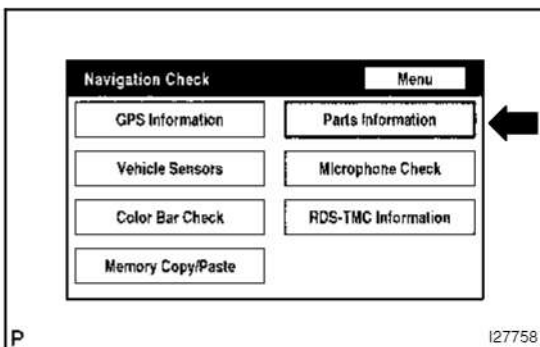

- (b) Select "Parts Information" from the "Navigation Check" screen.

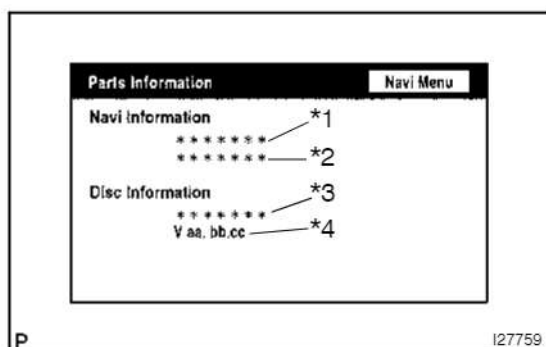

- (c) Check the navigation and disc information when the "Parts Information" screen is displayed.

Display	Contents
Navigation Manufacturer/*1	Navigation ECU manufacturer name is displayed.
Navigation Version/*2	Navigation ECU version is displayed.
Disc Manufacturer/*3	Map disc manufacturer is displayed.
Disc Version/*4	Map disc version is displayed.

10. DIAGNOSIS DISPLAY DETAILED DESCRIPTION

HINT:

- This section contains a detailed description of displays within diagnostic mode.
- Illustrations may differ from the actual vehicle depending on the device settings and options. Therefore, some detailed areas may not be shown exactly the same as on the actual vehicle.

(a) System check

(1) System check mode display

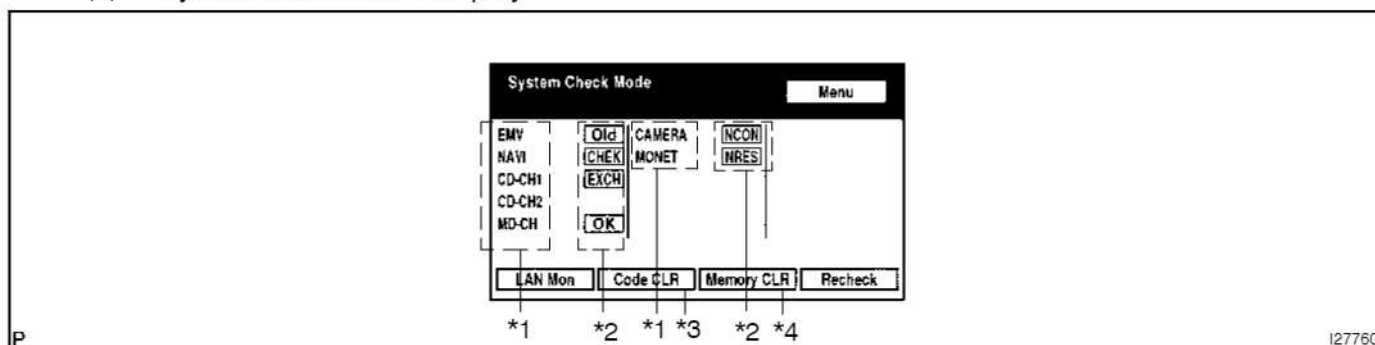

Device Names and hardware Address/*1

HINT:

- Registered device names are displayed below.
- If a device name is unknown to the system, its physical address is shown instead.

Address No.	Name	Address No.	Name
110	EMV	120	AVX
128	1DIN TV	140	AVN
144	G-BOOK	178	NAVI
17C	MONET	190	AUDIO H/U
1AC	CAMERA-C	1B0	Rr-TV
1C0	Rr-CONT	1C2	TV-TUNER2
1C4	PANEL	1C6	G/W
1C8	FM-M-LCD	1D8	CONT-SW
1EC	Body	1F0	RADIO TUNER
1F1	XM	1F2	SIRIUS
230	TV-TUNER	240	CD-CH2
250	DVD-CH	280	CAMERA
360	CD-CH1	3A0	MD-CH

Address No.	Name	Address No.	Name
17D	TEL	440	DSP-AMP
530	ETC	5C8	MAYDAY
1A0	DVD-P	1D6	CLOCK
1F4	RSA	1F6	RSE
480	AMP		

Check Result/*2

HINT:

Result codes for all devices are shown below.

Result	Meaning	Action
OK	The device did not respond with a DTC (excluding communication DTCs from the AVC-LAN).	-
EXCH	The device responds with a "replace"-type DTC.	Look up the DTC in "Unit Check Mode" and replace the device.
CHEK	The device responds with a "check"-type DTC.	Look up the DTC in "Unit Check Mode".
NCON	The device was previously present, but does not respond in diagnostic mode.	1. Check power supply wire harness of the device. 2. Check the AVC-LAN of the device.
Old	The device responds with an "old"-type DTC.	Look up the DTC in "Unit Check Mode".
NRES	The device responds in diagnostic mode, but gives no DTC information.	1. Check power supply wire harness of the device. 2. Check the AVC-LAN of the device.

Code Clear/*3

Present DTCs are cleared.

Memory Clear/*4

Present and past DTCs and registered connected device names are cleared.

(2) Diagnosis MENU Display

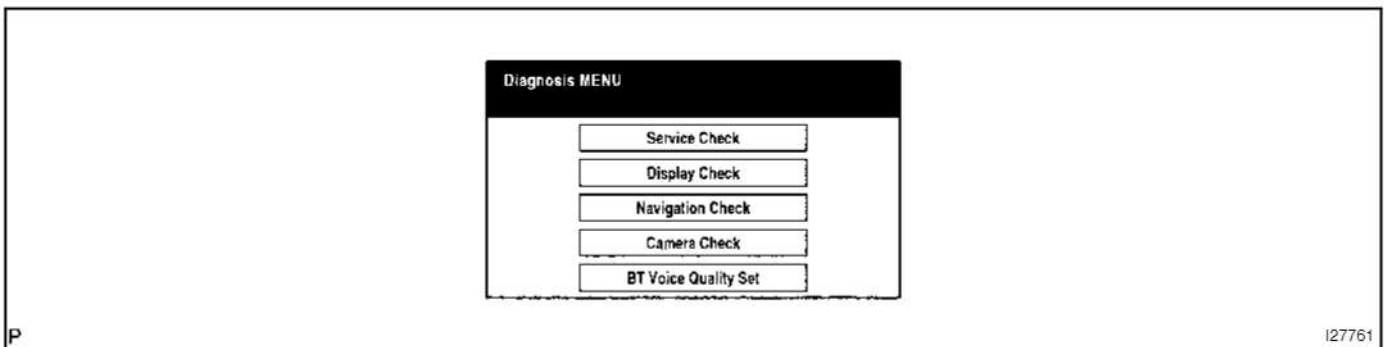

HINT:

Each item is grayed out or not displayed based on the device settings.

(3) Unit check mode screen

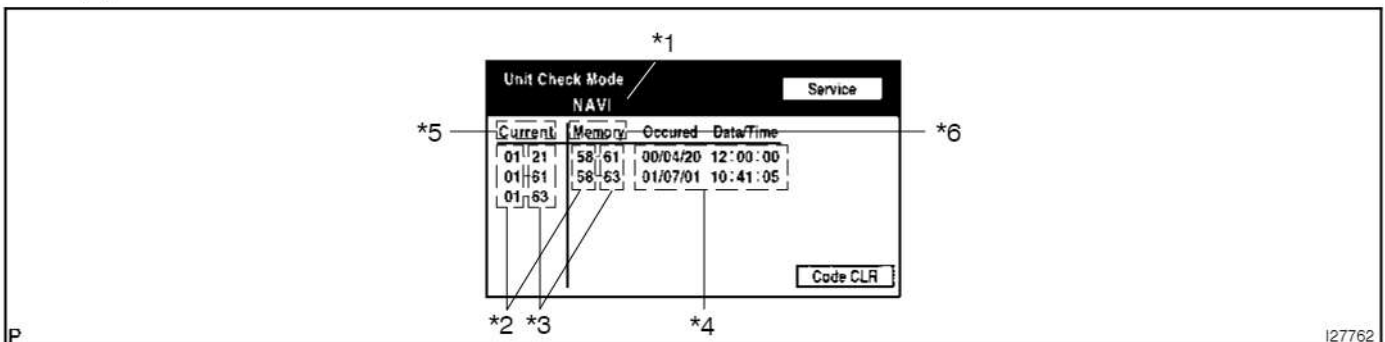

Screen Description

Display	Contents
Device name/*1	Target Device
Segment/*2	Target Device Logical address
DTC/*3	DTC (Diagnostic Trouble Code)
Timestamp/*4	The time and date of past DTCs are displayed. (The year is displayed in 2 digit format.)
Present Code/*5	The DTC output at the service check is displayed.
Past Code/*6	Diagnostic memory results and recorded DTCs are displayed.

(4) LAN monitor (Original) screen

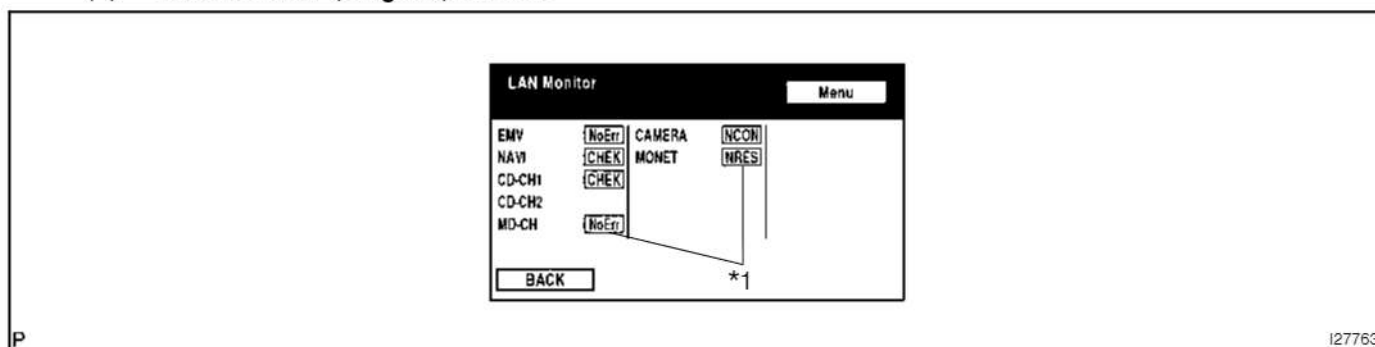

Check result

HINT:

Check results of all the devices are displayed.

Result	Meaning	Action
No Err (OK)	There are no communication DTCs.	-
CHEK	The device responds with a "check"-type DTC.	Look up the DTC in "Unit Check Mode".
NCON	The device was previously present, but does not respond in diagnostic mode.	1. Check power supply wire harness of the device. 2. Check the AVC-LAN of the device.
Old	The device responded with an old-type DTC.	Look up the DTC in "Unit Check Mode".
NRES	Device responds in diagnostic mode, but gives no DTC information.	1. Check power supply wire harness of the device. 2. Check the AVC-LAN of the device.

(5) LAN monitor (Individual) screen

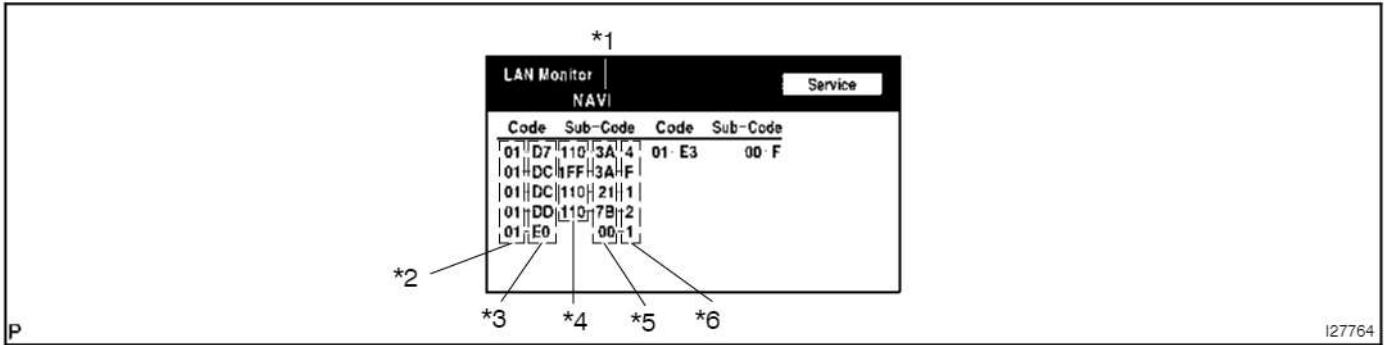

Screen Description

Display	Contents
Device name/*1	Target device
Segment/*2	Target logical address
DTC/*3	DTC (Diagnostic Trouble Code)
Sub-Code (device address)/*4	Physical address stored with DTC. (If there is no address, nothing is displayed.)
Connection check No./*5	Connection check number stored with DTC.
DTC occurrence/*6	Number of times the same DTC has been recorded.

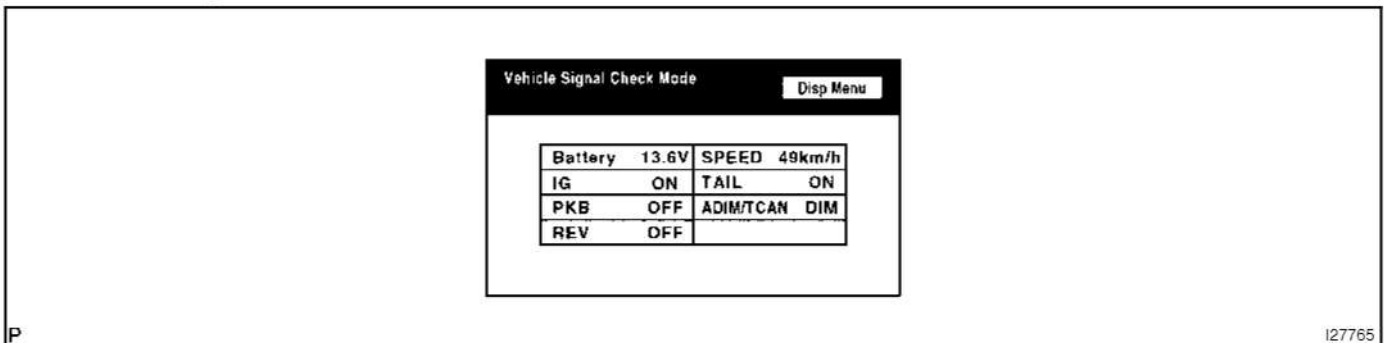
(b) Display check
Vehicle signal check mode screen

Screen Description

Name	Contents
Battery	Battery voltage is displayed.
PKB	Parking brake ON/OFF state is displayed.
REV	Reverse signal ON/OFF state is displayed.
IG	IG switch ON/OFF state is displayed.
ADIM/TCAN	Brightness state DIM (with)/ BRIGHT (without) is displayed.
SPEED	The vehicle speed is displayed in km/h.
TAIL	TAIL signal (Head lamp dimmer switch) ON/OFF state is displayed.

HINT:

- Only items sending a vehicle signal will be displayed.
- This screen is updated once per second when input signals to the vehicle are changed.

- (c) Navigation check
 (1) Navigation check MENU screen

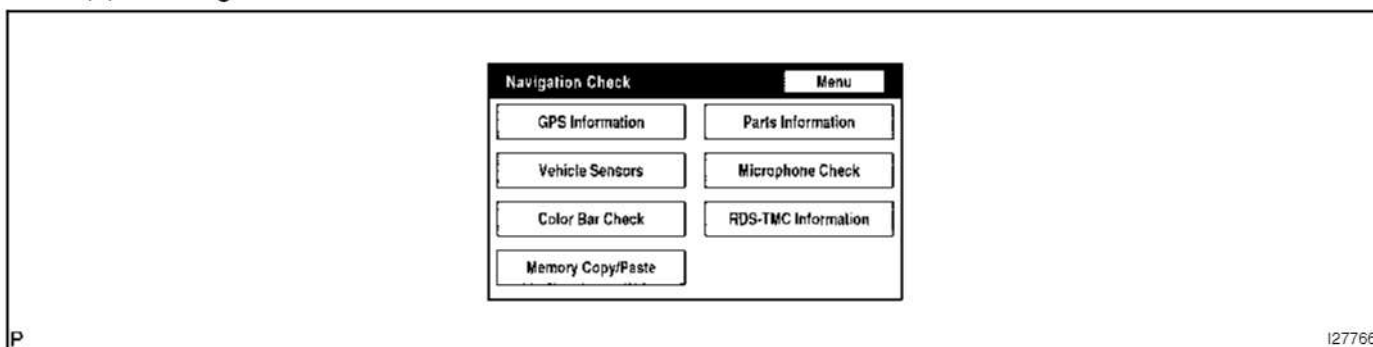

P

I27766

HINT:

Each item is grayed out or not displayed based on the device settings.

- (2) GPS information screen

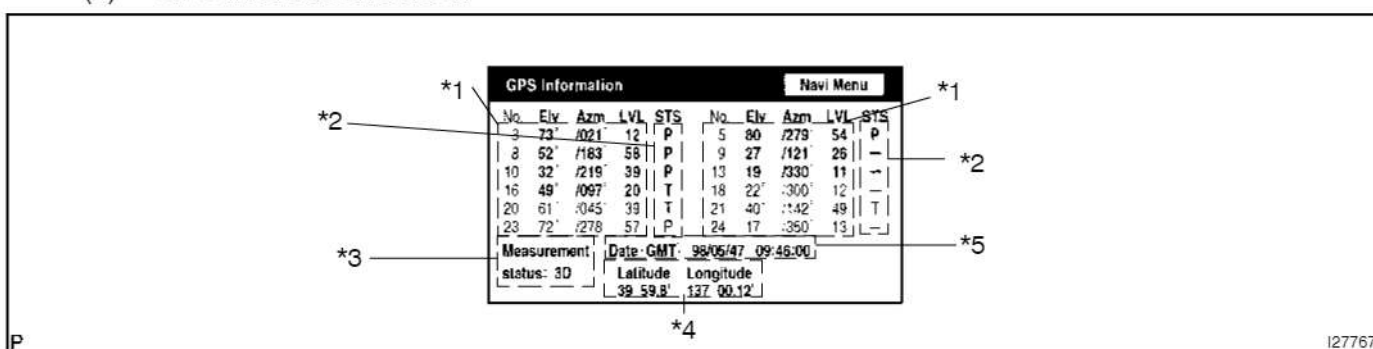

P

I27767

Satellite information/*1

Information from a maximum of 12 satellites is displayed on the screen. This information includes the target GPS satellite number, elevation angle, direction and signal level.

Receiving condition/*2

Display	Contents
01H	The system cannot receive a GPS signal.
02H	The system is tracing a satellite.
03H	The system is receiving a GPS signal, but is not using it for location.
04H	The system is using the GPS signal for location.

Measurement information/*3

Display	Contents
2D	2-dimensional location method is being used.
3D	3-dimensional location method is being used.
NG	Location data cannot be used.
Error	Reception error has occurred.
-	Any other state.

Position information/*4

Display	Contents
Position	Latitude and longitude information on the current position is displayed.

Date information/*5

Display	Contents
Date	The date/time information obtained from GPS signal is displayed in Greenwich mean time (GMT). The last 4 digits are displayed.

(3) Vehicle signal check screen

The screenshot shows the 'Vehicle Sensors' screen with a 'Navi Menu' button. The screen is divided into 'Vehicle Signal' and 'Sensor Signal' sections. The 'Vehicle Signal' section includes 'REV' (OFF) and 'SPD' (9999 Pulses, 75 mph, 120 km/h). The 'Sensor Signal' section includes 'Gyro Voltage' (2.500 V) and 'Relative bearing' (359.9 degrees). A 'Reset' button is at the bottom. Callouts *1, *2, and *3 point to the REV, SPD, and Gyro Voltage values respectively.

P I27768

Vehicle signal

Display	Contents
REV/*1	REV signal ON/OFF state is displayed.
SPD/*2	SPD signal condition is displayed.

Sensor signal

Display	Contents
Gyro sensor/*3	Gyro sensor output condition is displayed (when the vehicle runs straight or is stationary, the voltage is approximately 2.5 V).

HINT:

Signals are updated once per second only when vehicle sensor signals are changed.

(4) Parts information screen

The screenshot shows the 'Parts Information' screen with a 'Navi Menu' button. It is divided into 'Navi information' and 'Disc information' sections. 'Navi information' shows two lines of asterisks, with callouts *1 and *2 pointing to the second and third lines. 'Disc information' shows two lines of asterisks, with callouts *3 and *4 pointing to the second and third lines. The text 'V aa. bb.cc' is displayed below the asterisks.

P I27769

Screen description

Display	Contents
Navigation Manufacturer/*1	Navigation ECU manufacturer is displayed.
Navigation Version No.//*2	Navigation ECU version is displayed.
Disc Manufacturer/*3	Map disc manufacturer is displayed.
Disc Version No.//*4	Map disc version is displayed.

(5) Memory copy/paste screen

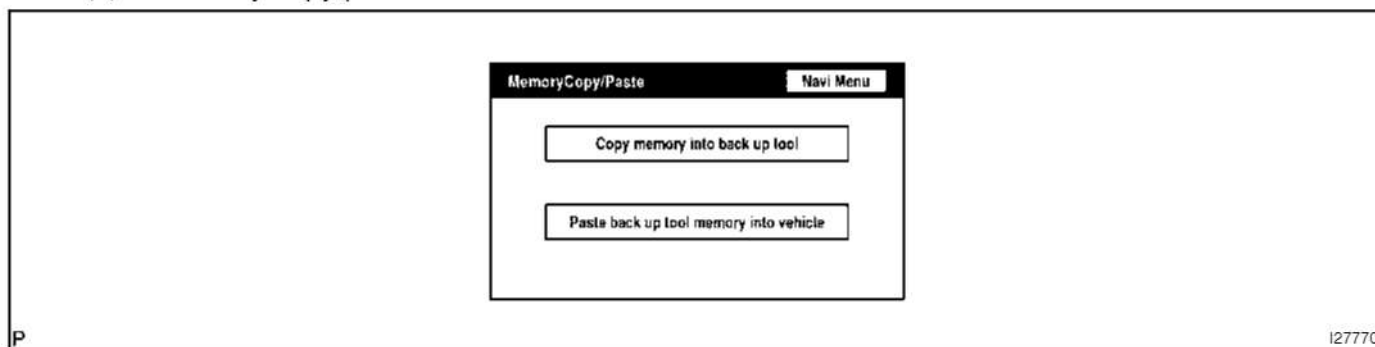

P

I27770

HINT:

This function cannot be used.

11. MICROPHONE CHECK

HINT:

- The microphone is checked in the "Navigation Check (Microphone Check)" mode.
- Illustrations may differ from the actual vehicle depending on vehicle specifications.

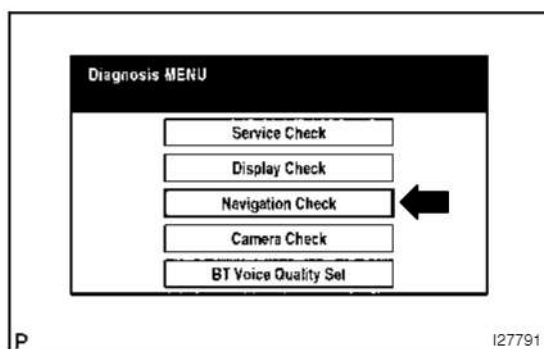

P

I27791

(a) Select "Navigation check" from "Diagnosis MENU"

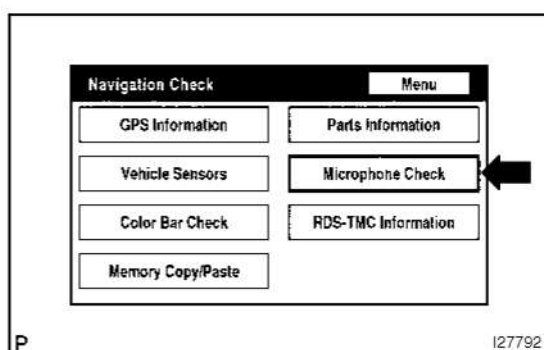

P

I27792

(b) Select "Microphone Check" from "Navigation Check".

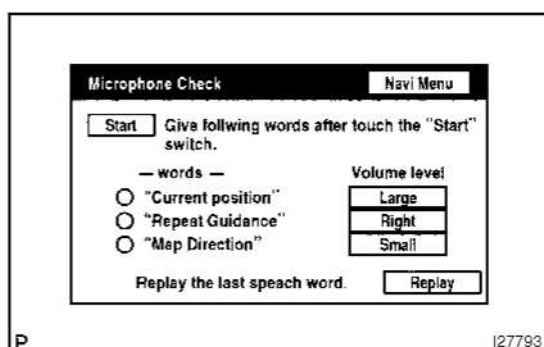

P

I27793

(c) Perform the microphone check by following the directions on the "Microphone Check" screen.

12. SCREEN NOISE AUTOMATIC ADJUSTMENT

HINT:

- This adjustment is performed to reduce noise when screen noise occurs upon replacing the multi-display, the navigation ECU or the television camera ECU.
- Illustrations may differ from the actual vehicle depending on the device settings and options. Therefore, some detailed areas may not be shown exactly the same as on the actual vehicle.
- Perform both procedures below when the multi-display is replaced.

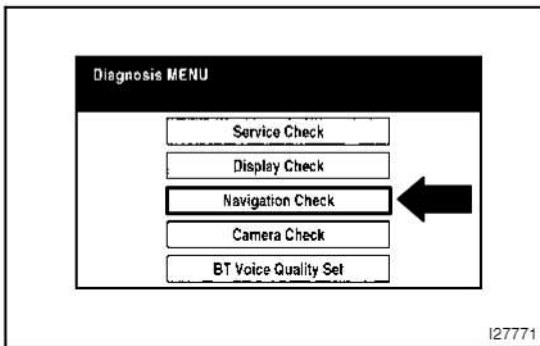

- (a) When either the multi-display or the navigation ECU is replaced:

- (1) Turn the ignition switch to the ACC position and wait for at least 6 seconds to activate the diagnostic mode.
- (2) Select "Navigation Check" from the "Diagnosis MENU" screen.

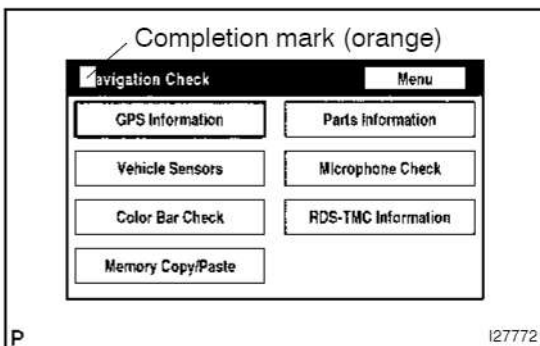

- (3) The screen enters "Navigation Check" with a beeping sound. Adjustment is completed when the completion mark is displayed.
- (4) Cancel the diagnostic mode.

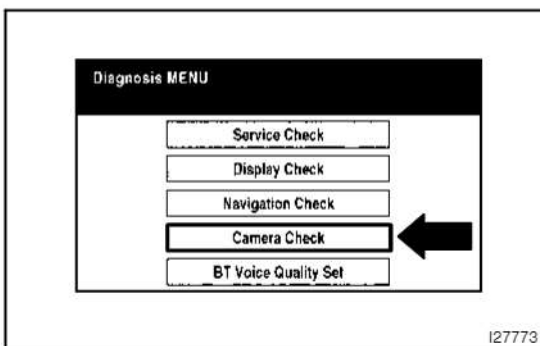

- (b) When either the multi-display or the television camera ECU is replaced:

- (1) Turn the ignition switch to the ACC position and wait for at least 6 seconds to activate the diagnostic mode.
- (2) Select "Camera Check" from the "Diagnosis MENU" screen.

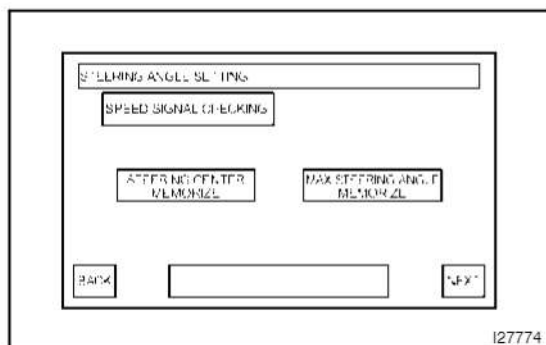

- (3) Adjustment is completed when the steering angle setting screen is displayed.
- (4) Cancel the diagnostic mode.

HINT:

- If the automatic adjustment is not performed (only step 1) only upon replacing the multi-display, a beeping sound can be heard for 3 seconds (while the initial screen is displayed) after turning the ignition switch to the ACC position.
- Perform the automatic adjustment again if a beeping sound can be heard within 3 seconds.

DIAGNOSTIC TROUBLE CODE CHART

Terms	Meaning
Physical address	Three-digit code (shown in hexadecimal) which is given to each component comprising the AVC-LAN. Corresponding to the function, individual symbols are specified.
Logical address	Two-digit code (shown in hexadecimal) which is given to each function comprising the inner system of the AVC-LAN.

1. PHYSICAL ADDRESS: 110 MULTI DISPLAY (EMV)

HINT:

- *1: Even if no failure is detected, it may be stored depending on the battery condition or voltage for starting an engine.
- *2: It is stored when 180 sec. has passed after the power supply connector is pulled out after engine start.
- *3: It may be stored when the engine key is turned again after engine start.
- *4: It may be stored when the engine key is turned again 1 min. after engine start.

(a) Logical address: 01 (Communication control)

DTC	Diagnosis item	Diagnosis content	Countermeasure and inspected parts
21	ROM Error	Abnormal condition of ROM is detected.	Replace multi-display assembly.
22	RAM Error	Abnormal condition of RAM is detected.	Replace multi-display assembly.
D5 *1	Registered component disconnected	Component shown by auxiliary code is or was disconnected from system with ignition switch in ACC or ON. Communication with component shown by auxiliary code is not ensured when engine is started.	<ul style="list-style-type: none"> • Check harness for power supply of component shown by auxiliary code. • Check harness for communication system of component shown by auxiliary code.
D8 *2	No response to connection check	Component shown by auxiliary code is or was disconnected from system after engine is started.	<ul style="list-style-type: none"> • Check harness for power supply of component shown by auxiliary code. • Check harness for communication system of component shown by auxiliary code.
D9 *1	Last Mode Error	Component operated (sound and/or image was provided) before engine stop is or was disconnected with ignition switch in ACC or ON.	<ul style="list-style-type: none"> • Check harness for power supply of component shown by auxiliary code. • Check harness for communication system of component shown by auxiliary code.
DB *1	Mode Status Error	Dual alarm is detected.	<ul style="list-style-type: none"> • Check harness for power supply system of component shown by auxiliary code. • Check harness for communication system of component shown by auxiliary code.
DC *4	Transmission Error	Transmission to component shown by auxiliary code has been failed. (This code does not necessarily mean actual failure.)	If same auxiliary code is recorded in order component(s), check harness for power supply and communication system of all components shown by code.
DE *3	Slave Reset (Momentary Interruption)	After engine start, slave component has been disconnected.	<ul style="list-style-type: none"> • Check harness for power supply system of component shown by auxiliary code. • Check harness for communication system of component shown by auxiliary code.
E2	ON/OFF Instruction Parameter Error	Error is detected in ON/OFF control command from multi-display assembly.	Replace multi-display assembly.
E3 *1	Registration Request Transmission	<ul style="list-style-type: none"> • Registration Request command is output from slave component. • By reception of connection check instruction, Registration Request command is output from sub-master component. 	Since this DTC is provided for engineering, it may be detected when no actual failure exists.

(b) Logical address: 21 (Switch)

DTC	Diagnosis item	Diagnosis content	Countermeasure and inspected parts
10	Panel Switch Error	Error in panel switch input part is detected. (Error in switch control part, or internal communication error with switch control part is detected.)	<ul style="list-style-type: none"> Inspect all switches on panel switch test screen in display check mode. If any of them does not function, replace multi-display assembly. If all switches function without problem, observe them for a while.

(c) Logical address: 34 (Front passenger monitor)

DTC	Diagnosis item	Diagnosis content	Countermeasure and inspected parts
10	Error in Picture Circuit	Error in power supply system for picture circuit (abnormal voltage) is detected.	Replace multi-display assembly.
11	Back-light Error (No current)	Decline in power output from inverter circuit for back-light.	Replace multi-display assembly.
12	Back-light Error (Excess current)	Excess power output from inverter circuit for back-light.	Replace multi-display assembly.

2. PHYSICAL ADDRESS: 1C6 GATEWAY ECU (G/W-ECU)

HINT:

*1: When 210 sec. have passed after pulling out the power supply connector of the master component with the ignition switch in ACC or ON, this code is stored.

Logical address: 01 (Communication control)

DTC	Diagnosis item	Diagnosis content	Countermeasure and inspected parts
D4 *1	Regular Communication Error	Component in which this code is recorded has been disconnected after engine start. Or, when this code was recorded, multi-display was disconnected.	<ul style="list-style-type: none"> Check harness for power supply system of multi-display assembly. Check harness for communication system of multi-display assembly. Check harness for power supply system of gateway ECU. Check harness for communication system of gateway ECU.

3. PHYSICAL ADDRESS: 190 RADIO RECEIVER (AUDIO H/U)

HINT:

- *1: Even if no failure is detected, it may be stored depending on the battery condition or voltage for starting an engine.
- *2: It is stored when 180 sec. have passed after the power supply connector is pulled out after engine start.
- *3: It may be stored when the engine key is turned 1 min. again after engine start.
- *4: It may be stored when the engine key is turned again after engine start.
- *5: When 210 sec. have passed after pulling out the power supply connector of the master component with the ignition switch in ACC or ON, this code is stored.

(a) Logical address: 01 (Communication control)

DTC	Diagnosis item	Diagnosis content	Countermeasure and inspected parts
D6 *1	Absence of Master	Component in which this code is recorded has been disconnected from system with ignition in ACC or ON. Or, when this code was recorded, multi-display assembly was disconnected.	<ul style="list-style-type: none"> • Check harness for power supply system of multi-display. • Check harness for communication system of multi-display. • Check harness for power supply system of radio receiver. • Check harness for communication system of radio receiver.
D8 *2	No Response to Connection Check	Component shown by auxiliary code is or had been disconnected from system after engine start. D9	<ul style="list-style-type: none"> • Check harness for power supply system of component shown by auxiliary code. • Check harness for communication system of component shown by auxiliary code.
D9 *1	Last Mode Error	Component operated (sounds and/or images were provided) before engine stop is or has been disconnected with ignition switch in ACC or ON.	<ul style="list-style-type: none"> • Check harness for power supply system of component shown by auxiliary code. • Check harness for communication system of component shown by auxiliary code.
DA	No Response to ON/OFF Instruction	No response is identified when changing mode (audio and visual mode change). Detected when sound and picture do not change by button operation.	<ul style="list-style-type: none"> • Check harness for power supply system of component shown by auxiliary code. • Check harness for communication system of component shown by auxiliary code. • If error occurs again, replace component shown by auxiliary code.
DB *1	Mode Status Error	Dual alarm is detected.	<ul style="list-style-type: none"> • Check harness for power supply of component shown by auxiliary code. • Check harness for communication system of component shown by auxiliary code.
DC *3	Transmission Error	Transmission to component shown by auxiliary code has been failed. (Detecting this DTC does not necessarily mean actual failure.)	If same auxiliary code is recorded in order component, check harness for power supply and communication system of all components shown by code.
DD *4	Master Reset (Momentary Interruption)	After engine is started, multi-display assembly was disconnected from system.	<ul style="list-style-type: none"> • Check harness for power supply system of multi-display. • Check harness for communication system of multi-display. • Check harness for power supply system of radio receiver. • Check harness for communication system of radio receiver. • If this error occurs frequently, replace multi-display assembly.
DE *4	Slave Reset (Momentary Interruption)	After engine is started, slave component was disconnected from system.	<ul style="list-style-type: none"> • Check harness for power supply of component shown by auxiliary code. • Check harness for communication system of component shown by auxiliary code.
DF *5	Master Error	Due to defective condition of component with a display, master function is switched to audio equipment. Error occurs in communication between sub-master (audio) and master component.	<ul style="list-style-type: none"> • Check harness for power supply of multi-display assembly. • Check harness for communication system of multi-display assembly. • Check harness for communication system between multi-display assembly and sub-master component.
E0 *1	Registration Completion Instruction Error	"Registration Completion Instruction" command from master cannot be received.	Since this DTC is provided for engineering purpose, it may be detected when no actual failure exists.

E1 *1	Audio processor ON error	While source equipment is operating, AMP output is stopped.	<ul style="list-style-type: none"> • Check harness for power supply of multi-display assembly. • Check harness for communication system of multi-display assembly.
E2	ON/OFF Instruction Parameter Error	Error occurs in ON/OFF controlling command from multi-display assembly.	Replace multi-display assembly.
E3 *1	Registration Request Transmission	Registration Request command is output from slave component. Receiving Connection Check Instruction, Registration Request command is output from sub-master component.	Since this DTC is provided for engineering purpose, it may be detected when no actual failure exists.
E4 *1	Multiple Frame Abort	Multiple frame transmission is aborted.	Since this DTC is provided for engineering purpose, it may be detected when no actual failure exists.

(b) Logical address: 61 (Cassette switch)

DTC	Diagnosis item	Diagnosis content	Countermeasure and inspected parts
40	Mechanical of Media Error	Malfunction due to mechanical failure is identified. Or cassette tape is cut or entangled.	<ul style="list-style-type: none"> • Inspect cassette tape. • Replace radio receiver.

4. PHYSICAL ADDRESS: 178 NAVIGATION ECU (NAVI-ECU)

HINT:

- *1: Even if no failure is detected, it may be stored depending on the battery condition or voltage for starting an engine.
- *2: When 210 sec. have passed after pulling out the power supply connector of the master component with the ignition switch in ACC or ON, this code is stored.
- *3: It may be stored when the engine key is turned 1 min. again after engine start.
- *4: It may be stored when the engine key is turned again after engine start.

(a) Logical address: 01 (Communication control)

DTC	Diagnosis item	Diagnosis content	Countermeasure and inspected parts
D6 *1	Absence of Master	Component in which this code is recorded has been disconnected from system with ignition in ACC or ON. Or, when this code was recorded, multi-display assembly was disconnected.	<ul style="list-style-type: none"> • Check harness for power supply system of multi-display. • Check harness for communication system of multi-display. • Check harness for power supply system of navigation ECU. • Check harness for communication system of navigation ECU.
D7 *2	Communication Check Error	Component in which this code is recorded has been disconnected from system after engine start. Or, when this code was recorded, multi-display assembly was disconnected. D6	<ul style="list-style-type: none"> • Check harness for power supply system of multi-display. • Check harness for communication system of multi-display. • Check harness for power supply system of navigation ECU. • Check harness for communication system of navigation ECU.
DC *3	Transmission Error	Transmission to component shown by auxiliary code has been failed. (This code does not necessarily mean actual failure.)	If same auxiliary code is recorded in other component(s), check harness for power supply and communication system of all components shown by code.

DD *4	Master Reset (Momentary Interruption)	Component that is to be master has been disconnected after engine start.	<ul style="list-style-type: none"> • Check harness for power supply system of multi-display assembly. • Check harness for communication system of multi-display assembly. • If error occurs frequently, replace multi-display assembly.
DF *5	Master Error	Due to defective condition of component with a display, master function is switched to audio equipment. Error occurs in communication between sub-master (audio) and master component.	<ul style="list-style-type: none"> • Check harness for power supply of multi-display assembly. • Check harness for communication system of multi-display assembly. • Check harness for communication system between multi-display assembly and sub-master component.
E0 *1	Registration Completion Instruction Error	"Registration Completion Instruction" command from master cannot be received.	Since this DTC is provided for engineering purpose, it may be detected when no actual failure exists.
E2	ON/OFF Instruction Parameter Error	Error is detected in ON/OFF control command from multi-display assembly.	Replace multi-display assembly.
E3 *1	Registration Request Transmission	<ul style="list-style-type: none"> • Registration Request command is output from slave component. • Registration Request command is output from sub-master component. 	Since this DTC is provided for engineering purpose, it may be detected when no actual failure exists.
E4 *1	Multiple Frame Abort	Multiple frame transmission is aborted.	Since this DTC is provided for engineering purpose, it may be detected when no actual failure exists.

(b) Logical address: 58 (Navigation ECU)

DTC	Diagnosis item	Diagnosis content	Countermeasure and inspected parts
10	Gyro Error	Error in gyro sensor is detected. (Abnormal value in voltage output from sensor is detected for more than specified time.)	Replace navigation ECU.
11	GPS Receiver Error	Operation error of GPS receiver is detected.	At an outdoor site with a clear view, operate to display GPS data. If GPS mark is not properly displayed after 15 min. or more, replace navigation ECU.
40	GPS Antenna Error	Open condition of GPS antenna is detected. (Open circuit, connection failure of connectors, etc.)	Inspect antenna and replace if necessary.
41	Power Supply Error of GPS Antenna	Abnormal voltage of GPS antenna cable or short circuit is detected.	<ul style="list-style-type: none"> • Inspect GPS antenna and replace if necessary. (When no continuity is identified between connector's core and sealed part, GPS antenna is normal.) • If GPS antenna is normal, replace navigation ECU.
42	Map Disc Error	Data cannot be read for a certain time due to scratches or dirt on disc surface or insertion of disc.	Inspect disc and replace if necessary. (Visually check disc surface and wipe it with soft cloth.)
43	Vehicle Signal Error	Input error of vehicle signal is detected. (When no vehicle signal has been input for a certain time.)	<ul style="list-style-type: none"> • Inspect wire harness. • If wire harness is normal, replace navigation ECU.

PARTS LOCATION

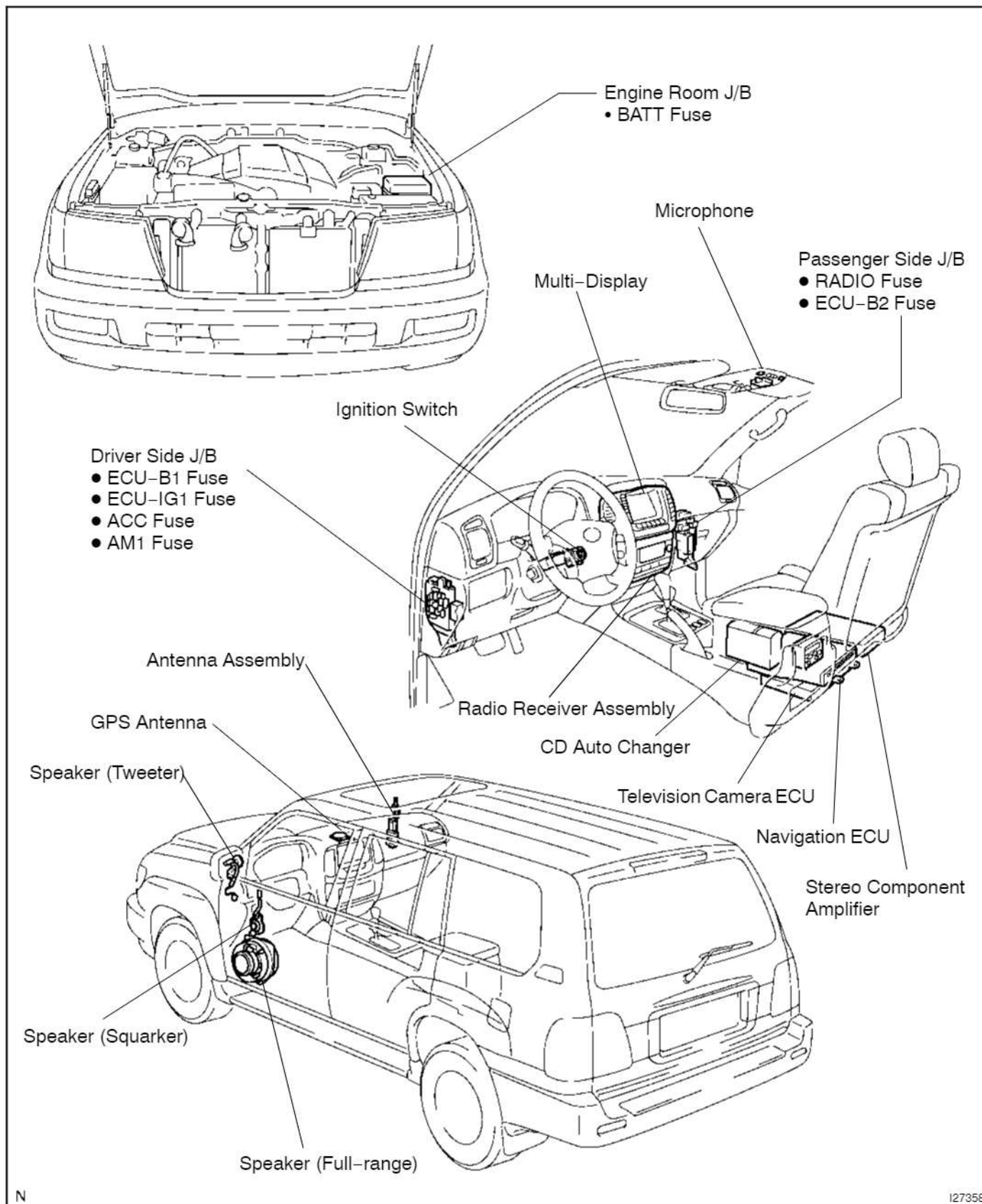

TERMINALS OF ECU

Multi-display:

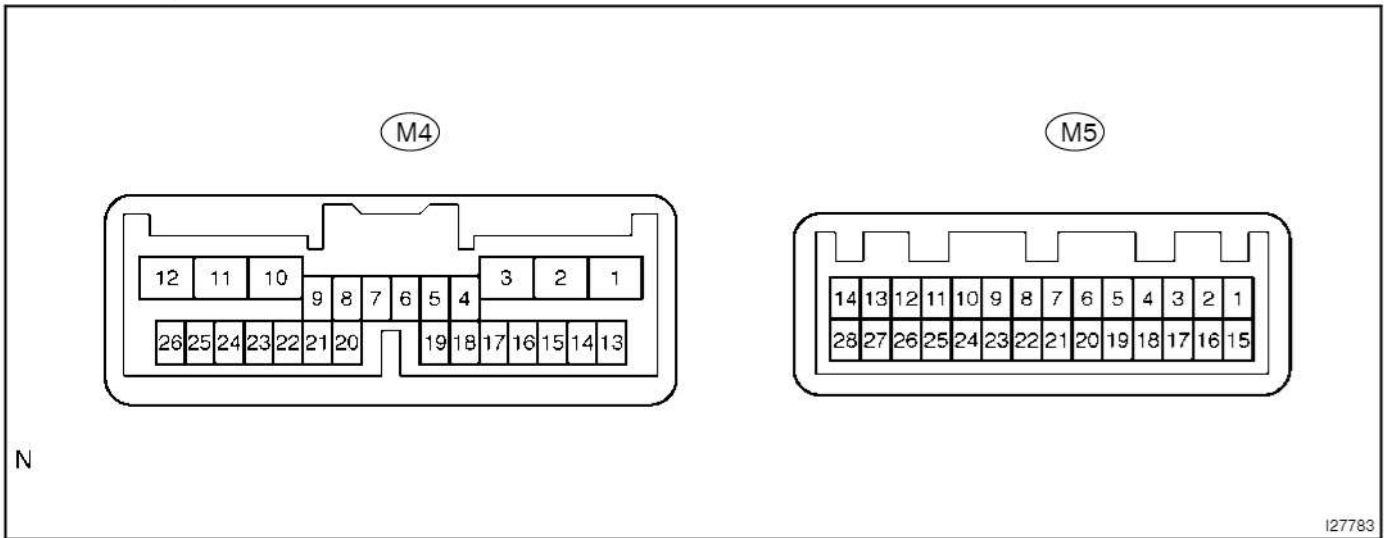

Symbols (Terminals No.)	Wiring Color	Terminal Description	Condition	Specification
GND1 (M4-3) – Body ground	W-B – Body ground	Ground	Always	Below 1 V
TX1+ (M4-4) – GND1 (M4-3)	P – W-B	AVC-LAN communication signal	Turn ignition switch to ON	2 to 3 V
TX1- (M4-5) – GND1 (M4-3)	L-B – W-B	AVC-LAN communication signal	Turn ignition switch to ON	2 to 3 V
TC (M4-7) – GND1 (M4-3)	P-B – W-B	Diagnosis ON signal	Turn ignition switch to the ON position	9 to 14 V
IG (M4-10) – GND1 (M4-3)	B-W – W-B	Ignition (ON)	Turn ignition switch OFF → ON	Below 1 V → 10 to 14 V
ACC (M4-11) – GND1 (M4-3)	GR – W-B	Accessory (ON)	Turn ignition switch OFF → ACC or ON	Below 1 V → 10 to 14 V
B1 (M4-12) – GND1 (M4-3)	L-W – W-B	Battery	Always	10 to 14 V
PKB (M4-16) – GND1 (M4-3)	R-W – W-B	Parking brake signal	Turn parking brake switch ON → OFF	Below 1 V → 10 to 14 V
SPD (M4-25) – GND1 (M4-3)	V – W-B	Speed signal from combination meter	See "vehicle signal check mode"	
SGND (M5-3) – GND1 (M4-3)	W-B – W-B	Screen noise or other types of noise occurs	Ignition switch OFF	Below 1 V
MIN+ (M5-4) – GND1 (M4-3)	B – W-B	Microphone voice signal	See "microphone check"	-
MIN- (M5-5) – Body ground	W – Body ground	Microphone voice signal	See "microphone check"	-
MACC (M5-6) – GND1 (M4-3)	Y-G – W-B	Microphone Accessory	Turn ignition switch OFF → ON	Below 1 V → 10 to 14 V
TX3+ (M5-11) – GND1 (M4-3)	P-L – W-B	AVC-LAN communication signal	Turn ignition switch to ON	2 to 3 V
TX3- (M5-12) – GND1 (M4-3)	P-B – W-B	AVC-LAN communication signal	Turn ignition switch to ON	2 to 3 V
TX+ (M5-13) – GND1 (M4-3)	P – W-B	AVC-LAN communication signal	Turn ignition switch to ON	2 to 3 V
TX- (M5-14) – GND1 (M4-3)	L – W-B	AVC-LAN communication signal	Turn ignition switch to ON	2 to 3 V

DIAGNOSTICS - NAVIGATION SYSTEM

SGND (M5-17) - GND1 (M4-3)	Shielded - W-B	Screen noise or other types of noise occurs	Ignition switch OFF	Below 1 V
MCO+ (M5-18) - GND1 (M4-3)	B - W-B	Microphone voice signal	See "microphone check"	-
MCO- (M5-19) - GND1 (M4-3)	W - W-B	Microphone voice signal	See "microphone check"	-
IVO+ (M5-21) - GND1 (M4-3)	O - W-B	Telephone voice signal (buletooth)	See "microphone check"	-
IVO- (M5-22) - GND1 (M4-3)	W - W-B	Telephone voice signal (buletooth)	See "microphone check"	-
VR (M5-23) - GND1 (M4-3)	B - W-B	Video return signal	Turn ignition switch OFF	Below 1 V
R (M5-24) - GND1 (M4-3)	Y - W-B	Display signal (red)	Navigation display is on	Pulse generation *2
G (M5-25) - GND1 (M4-3)	W - W-B	Display signal (green)	Navigation display is on	Pulse generation *2
B (M5-26) - GND1 (M4-3)	R - W-B	Display signal (blue)	Navigation display is on	Pulse generation *2
SYNC (M5-27) - GND1 (M4-3)	G - W-B	Display signal (synchronize)	Navigation display is on	Pulse generation *1
VG (M5-28) - Body ground	Shielded - Body ground	Shielded ground	Always	Below 1 V

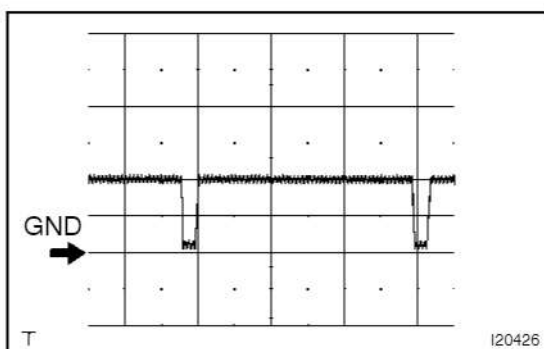

- *1: Oscilloscope wave
Terminal to be measured: SYNC - GND1
Setting for measurement: 500 mV/DIV 10 μ s/DIV
Condition: Navigation display is displayed.

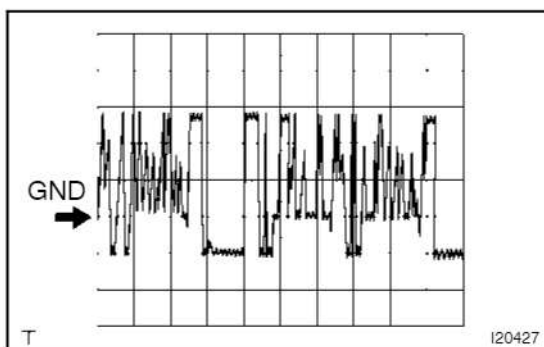

- *2: Oscilloscope wave
Terminal to be measured: R, G, B - GND1
Setting for measurement: 200 mV/DIV 10 μ s/DIV
Condition: Navigation map is switched.

Navigation ECU

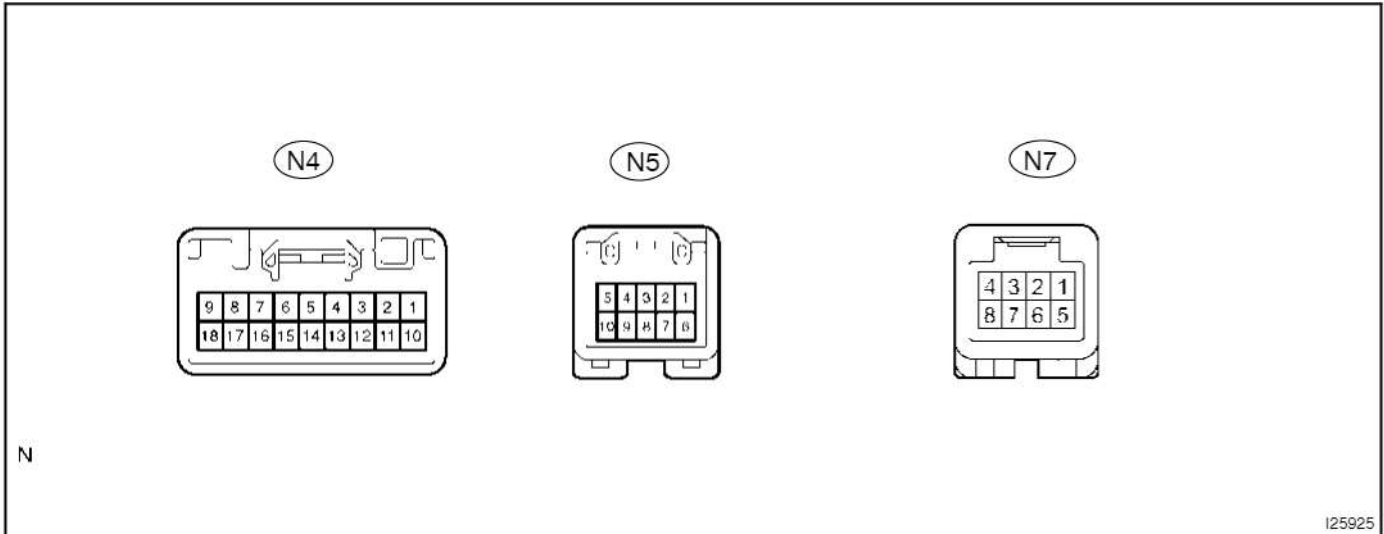

Symbols (Terminals No.)	Wiring Color	Terminal Description	Condition	Specification
AUI+ (N4-1) - GND (N4-17)	P - W-B*1 LG - W-B*2	Sound signal (input)	Audio system is playing	-
AUO+ (N4-2) - GND (N4-17)	P - W-B*1 LG - W-B*2	Sound signal (output)	Audio system is playing	-
SLD1 (N4-3) - Body ground	Shielded - Body ground	Shielded ground	Always	Below 1.0 V
SPD (N4-5) - GND1 (N4-17)	V - W-B	Speed signal from combination meter	See "Vehicle Signal Check Mode" (see page DI-175)	-
+B (N4-9) - GND (N4-17)	L-Y - W-B	Battery	Always	10 to 14 V
AUI- (N4-10) - GND (N4-17)	V - W-B*1 L - W-B*2	Sound signal (input)	Audio system is playing	-
AUO- (N4-11) - GND (N4-17)	V - W-B*1 L - W-B*2	Sound signal (output)	Audio system is playing	-
VOI+ (N4-12) - Body ground	O - Body ground	Telephone voice signal (buleetooth)	See "microphone check"	-
VOI- (N4-13) - Body ground	W - Body ground	Telephone voice signal (buleetooth)	See "microphone check"	-
REV (N4-14) - GND (N4-17)	R-B - W-B	Reverse signal from combination meter	See "Vehicle Signal Check Mode" (see page DI-175)	-
GND (N4-17) - Body ground	W-B - Body ground	Ground	Always	Below 1 V
ACC (N4-18) - GND (N4-17)	GR - W-B	Accessory (ON)	Turn ignition switch OFF → ACC or ON	Below 1 V → 10 - 14 V
VR (N5-1) - GND (N4-17)	B - W-B	Video return signal	Turn ignition switch OFF	Below 1 V
R (N5-2) - GND (N4-17)	Y - W-B	Display signal (red)	Navigation display is on	Pulse generation *2
B (N5-3) - GND (N4-17)	R - W-B	Display signal (blue)	Navigation display is on	Pulse generation *2
TX+ (N5-5) - GND (N4-17)	P - W-B	AVC-LAN communication signal	Turn ignition switch to ACC	2 to 3 V
VG (N5-6) - Body ground	Shielded - Body ground	Shielded ground	Always	Below 1 V
G (N5-7) - GND (N4-17)	W - W-B	Display signal (green)	Navigation display is on	Pulse generation *2

DIAGNOSTICS - NAVIGATION SYSTEM

SYNC (N5-8) - GND (N4-17)	G - W-B	Display signal (synchronize)	Navigation display is on	Pulse generation *1
TX- (N5-10) - GND (N4-17)	L-B - W-B	AVC-LAN communication signal	Turn ignition switch to ACC	2 to 3 V
MIC+ (N7-3) - GND (N4-17)	B - W-B	Microphone voice signal	See "microphone check"	-
MIC- (N7-5) - GND (N4-17)	W - W-B	Microphone voice signal	See "microphone check"	-

*1: LHD

*2: RHD

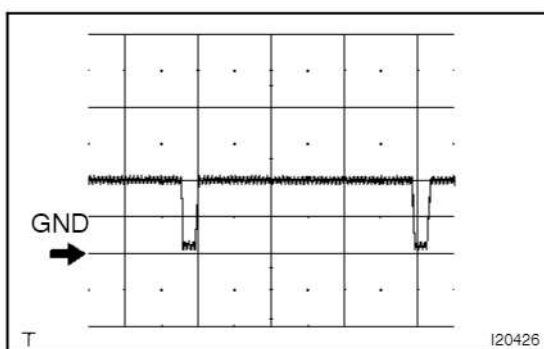

- *1: Oscilloscope wave
Terminal to be measured: SYNC - GND1
Setting for measurement: 500mV/DIV 10 μ s/DIV
Condition: Navigation display is displayed

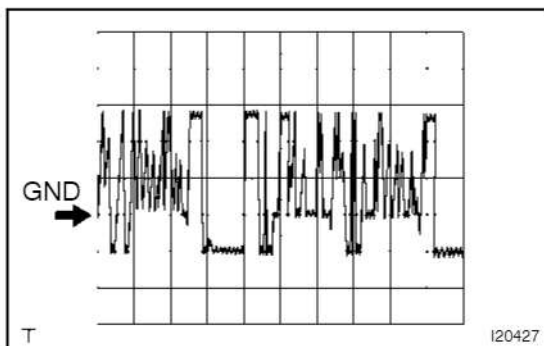

- *2: Oscilloscope wave
Terminal to be measured: R, G, B - GND1
Setting for measurement: 200mV/DIV 10 μ s/DIV
Condition: Navigation map is switched.

Radio receiver assembly

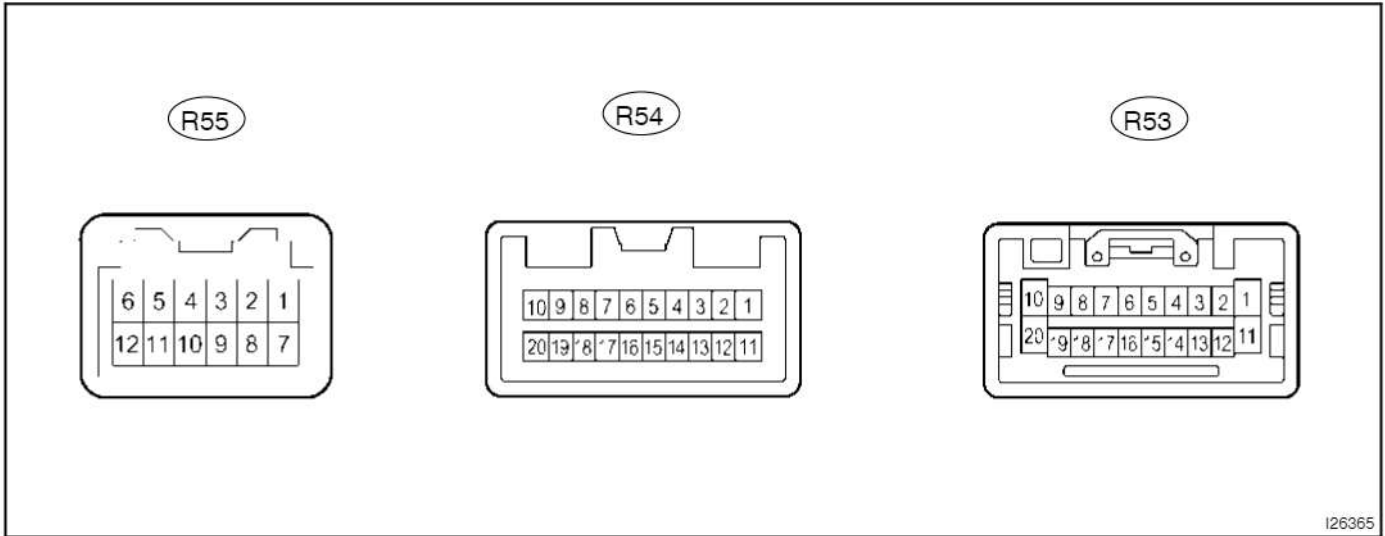

I26365

Symbols (Terminal No.)	Condition	STD Voltage (V)	Problem symptom when open circuit is detected.
			Problem symptoms when short circuit is detected.
BU ↔ GND (R53-1 ↔ R53-20)	Always	10 - 14 V	Audio system does not operate.
ILL+ ↔ GND (R53-2 ↔ R53-20)	Light control switch TAIL	10 - 14 V	Audio head unit illumination does not come on.
TX+ (R53-5)	AVC-LAN Communication circuit	-	Audio system does not operate.
MUTE ↔ GND (R53-7 ↔ R53-20)	-	-	-
R+ ↔ GND (R53-8 ↔ R53-20)	Always	10 - 14 V	Sound from right speaker is small
L+ ↔ GND (R53-9 ↔ R53-20)	Always	10 - 14 V	Sound from left speaker is small
ACC ↔ GND (R53-11 ↔ R53-20)	Ignition switch ACC	10 - 14 V	Audio system does not operate.
ILL- ↔ GND (R53-12 ↔ R53-20)	Light control switch TAIL	Below 0.5 V	Audio head unit illumination does not come on.
ANT ↔ GND (R53-13 ↔ R53-20)	Radio switch ON	10 - 14 V	Antenna does not extend.
TX- (R53-15)	AVC-LAN Communication circuit	-	Audio system does not operate.
R- ↔ GND (R53-18 ↔ R53-20)	Always	10 - 14 V	Sound from right side speaker is small.
L- ↔ GND (R53-19 ↔ R53-20)	Always	10 - 14 V	Sound from left side speaker is small.
GND ↔ Body ground (R53-20 ↔ Body ground)	Always	Continuity	Audio system is normal.
TX+ (R54-9)	Ignition Switch ACC	2 - 3 V	Navigation system does not operate.
TX- (R54-10)	Ignition Switch ACC	2 - 3 V	Navigation system does not operate.

DIAGNOSTICS - NAVIGATION SYSTEM

R+ (R55-2)	-	-	Sound from right side speaker is small
R- (R55-3)	-	-	Sound from right side speaker is small
L+ (R55-4)	-	-	Sound from left side speaker is small
L- (R55-5)	-	-	Sound from left side speaker is small
MUTE (R55-6)	-	-	Pop sound etc. Speaker does not sound
TX+ (R55-9)	Ignition Switch ACC	2 - 3 V	Audio system does not operate.
TX- (R55-10)	Ignition Switch ACC	2 - 3 V	Audio system does not operate.

Stereo component amplifier

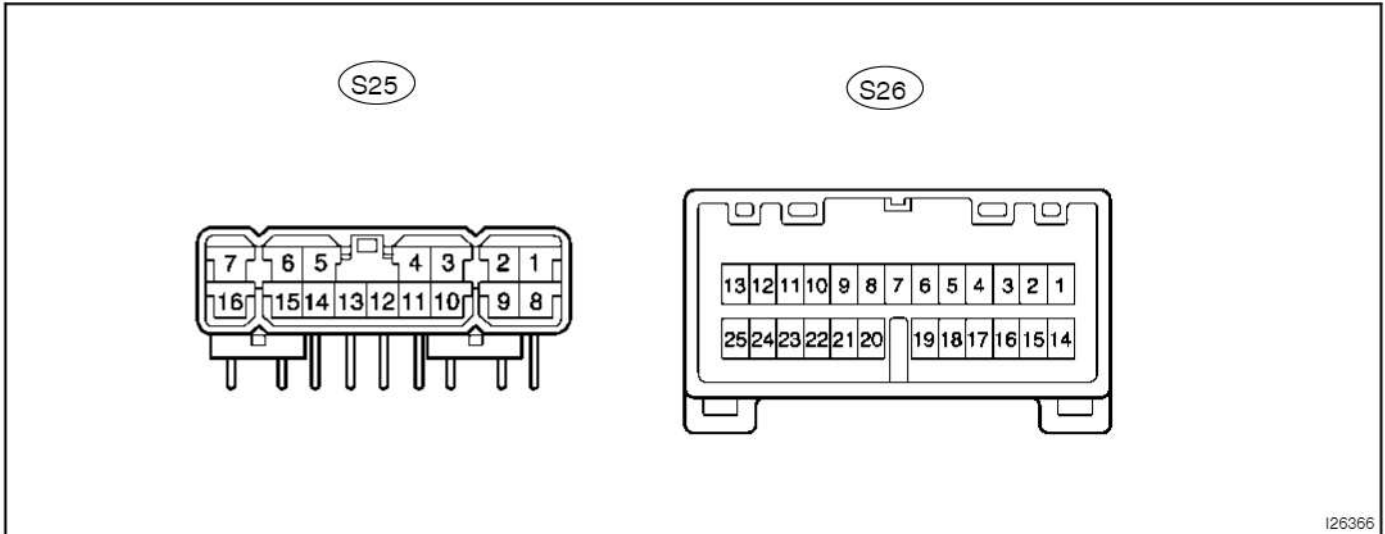

I26366

Symbols (Terminal No.)	Condition	STD Voltage (V)	Problem symptom when open circuit is detected.
FR+ ↔ E (S25-1 ↔ S25-12)	Radio switch ON	5 - 7 V	RH side speaker does not sound.
FL+ ↔ E (S25-2 ↔ S25-12)	Radio switch ON	5 - 7 V	LH side speaker does not sound.
RR+ ↔ E (S25-3 ↔ S25-12)	Radio switch ON	5 - 7 V	Rear RH side speaker does not sound.
RL+ ↔ E (S25-4 ↔ S25-12)	Radio switch ON	5 - 7 V	Rear LH side speaker does not sound.
WFR+ ↔ E (S25-5 ↔ S25-12)	Radio switch ON	5 - 7 V	Woofers speaker does not sound.
WFL+ ↔ E (S25-6 ↔ S25-12)	Radio switch ON	5 - 7 V	Woofers speaker does not sound.
+B ↔ E (S25-7 ↔ S25-12)	Always	10 - 14 V	All speakers do not sound
FR- ↔ E (S25-8 ↔ S25-12)	Radio switch ON	5 - 7 V	RH side speaker does not sound.
FL- ↔ E (S25-9 ↔ S25-12)	Radio switch ON	5 - 7 V	LH side speaker does not sound.
RR- ↔ E (S25-10 ↔ S25-12)	Radio switch ON	5 - 7 V	Rear RH side speaker does not sound.
RL- ↔ E (S25-11 ↔ S25-12)	Radio switch ON	5 - 7 V	Rear LH side speaker does not sound.
E ↔ Body ground (S25-12 ↔ Body ground)	Always	Continuity	-
GND2 ↔ Body ground (S25-13 ↔ Body ground)	Always	Continuity	-
WFR- ↔ E (S25-14 ↔ S25-12)	Radio switch ON	5 - 7 V	Woofers speaker does not sound.
WFL- ↔ E (S25-15 ↔ S25-12)	Radio switch ON	5 - 7 V	Woofers side speaker does not sound.
+B2 ↔ GND2 (S25-16 ↔ S25-13)	Always	10 - 14 V	All speakers do not sound

DIAGNOSTICS - NAVIGATION SYSTEM

TX+ (S26-5)	Ignition switch ACC	2 - 3 V	Audio system does not operate.
N-MU ↔ E (S26-9 ↔ S25-12)	Radio switch ON	5 - 7 V	Audio system does not operate.
R+ ↔ E (S26-11 ↔ S25-12)	Always	10 - 14 V	Sound from RH speaker is small.
L+ ↔ E (S26-12 ↔ S25-12)	Always	10 - 14 V	Sound from LH speaker is small.
SPD - E (S26-13 - S25-12)	-	-	-
TX- (S26-18)	Ignition switch ACC	2 - 3 V	Audio system does not operate.
ACC ↔ E (S26-20 ↔ S25-12)	Ignition switch ACC	10 - 14 V	Audio system does not operate.
MUTE ↔ E (S26-21 ↔ S25-12)	Radio switch ON	5 - 7 V	Audio system does not operate.
ASGD ↔ E (S26-22 ↔ S25-12)	-	-	-
R- ↔ E (S26-23 ↔ S25-12)	Always	10 - 14 V	Sound from RH speaker is small.
L- ↔ E (S26-24 ↔ S25-12)	Always	10 - 14 V	Sound from LH speaker is small.

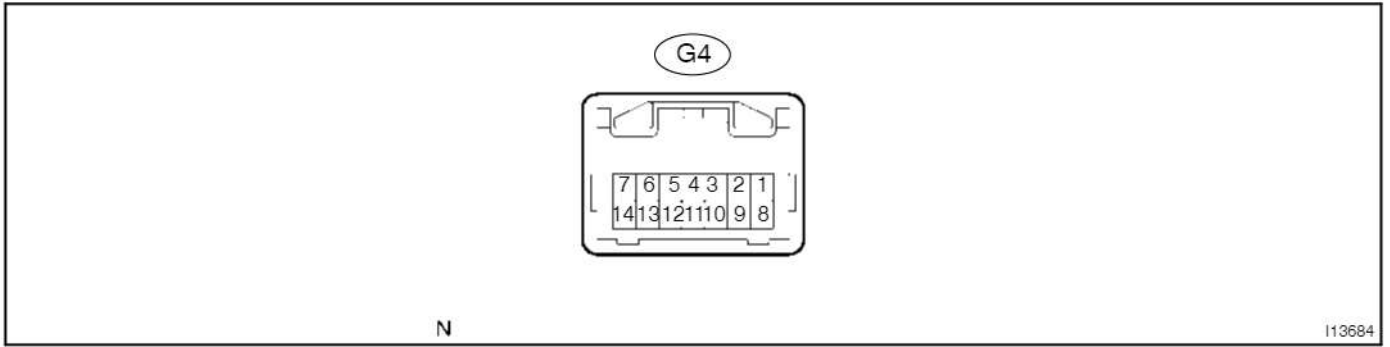
Gateway ECU:

Symbols (Terminals No.)	Wiring Color	Condition	STD Voltage (V)
IG ↔ GND (G4-2 ↔ G4-14)	B-W ↔ W-B	Ignition switch ON.	10 - 14 V
MPD1 (G4-4)	B	Communication circuit (Gateway ECU and Center ECU)	-
GTX+ (G4-5)	P-L	Ignition switch ACC	2 - 3 V
CG ↔ Body ground (G4-7 ↔ Body ground)	BR ↔ Body ground	Always	Continuity
BATT ↔ GND (G4-8 ↔ G4-14)	L-W ↔ W-B	Always	10 - 14 V
MPD2 (G4-11)	P-B	Communication circuit (Gateway ECU and Center ECU)	-
GTX- (G4-12)	P-B	Ignition switch ACC	2 - 3 V
GND ↔ Body ground (G4-14 ↔ Body ground)	W-B ↔ Body ground	Always	Continuity

PROBLEM SYMPTOMS TABLE

Flow chart No. (See page)	Component	Symptom
1. (DI-211)	Multi display	Black screen (Nothing displayed)
2. (DI-212)		No sound with Power switch pressed. ("AUTO OFF" on audio screen)
3. (DI-215)		No navigation screen displayed when "MAP", "MENU" or "DEST" switch pressed. (Screen cannot be switched.)
4. (DI-217)		No corresponding screen displayed when "AUDIO" or "Information" switch pressed.
5. (DI-218)		No navigation displayed, "Audio OFF" on audio screen and no audio sound.
6. (DI-220)		Screen cannot be dimmed in night time.
7. (DI-221)		Navigation screen not stabilized. (Synchronous error)
8. (DI-222)		Color on navigation screen is unusual (RGB signal error)
9. (DI-224)		Black screen appears when "MAP", "Menu" or "DEST" switch pressed.
10. (DI-225)		Sound of radio, cassette tape or CD only cannot be heard from speaker.
11. (DI-226)		No sound (radio, cassette tape, CD) can be heard from driver side door speaker only.
12. (DI-228)		Map DISC cannot be inserted.
13. (DI-229)		MAP screen display does not appear. (Disc Caution screen does not change.)
14. (DI-230)		MAP is displayed in white or blue screen. (Switch and vehicle position mark is displayed.)
15. (DI-231)		Touch switch does not function. (Navigation screen only)
16. (DI-232)		Touch switch does not function. (A/C control screen only)
17. (DI-233)		Panel switch does not function. (Navigation screen only)
18. (DI-234)		Panel switch does not function. (A/C control screen only)
19. (DI-235)		The screen cannot be changed to night mode color.
20. (DI-237)		Vehicle position is deviated from correct point badly.
21. (DI-240)		GPS mark does not appear.

22. (DI-242)		No voice navigation.
23. (DI-243)		Vehicle position rotates without control. (Map rotates without control)
24. (DI-245)		Driving direction is opposite to moving direction of vehicle position mark.
25. (DI-246)		Navigation system cannot be operated with voice recognition.
26. (DI-247)	Bluetooth System	Cellular phone registration failure, phone directory transfer failure
27. (DI-249)		The cellular phone cannot send/receive
28. (DI-252)		Cannot call in a certain place
29. (DI-253)		Voice on phone cannot be heard, too quiet, distorted
30. (DI-254)		Own voice cannot be heard, too quiet or distorted

CIRCUIT INSPECTION

1. Black screen (Nothing displayed)

INSPECTION PROCEDURE

1 Check the ECU-IG fuse.

NG

Replace the fuse.

OK

2 Check multi-display power source circuit ([see page DI-259](#)).

NG

Replace or repair wire harness or connector.

OK

Replace the mult-display.

2. No sound with POWER switch pressed. ("Audio OFF" on audio screen)

INSPECTION PROCEDURE

1 Service check mode. (Check radio receiver assembly)

NG

Troubleshoot for each diagnosis.

OK

2 Check the radio receiver assembly.

PREPARATION:

Disconnect the radio receiver assembly connector.

CHECK:

Check voltage at terminal +B.

OK:

+B: 10 – 14 V

CHECK:

Check voltage at terminal ACC when turning ignition switch to the ACC or ON position.

OK:

ACC: 10 – 14 V

CHECK:

Check continuity at terminal GND1.

OK:

GND: Continuity

NG

Replace or repair wire harness or connector.

OK

3	Check the stereo component amplifier.
----------	--

PREPARATION:

Disconnect the stereo component amplifier connector.

CHECK:

Check voltage at terminals +B and +B2.

OK:

+B and +B2: 10 – 14 V

CHECK:

Check voltage at terminal ACC when turning the ignition switch to ACC or ON position.

OK:

ACC: 10 – 14 V

CHECK:

Check continuity at terminals GND2 and E.

OK:

GND2 and E: Continuity

NG

Replace or repair wire harness or connector.

OK

4	Check wire harness and connector between radio receiver and stereo component amplifier (See page IN-38).
----------	---

NG

Repair or replace wire harness or connector.

OK

5	Check the stereo component amplifier.
----------	--

PREPARATION:

Disconnect the stereo component amplifier connector.

CHECK:

Check voltage at terminal MUTE.

OK:

MUTE: Above 3.5 V (When audio is sounding)

NG

Replace or repair wire harness or connector.

OK

Replace the radio receiver assembly.

3. No navigation screen displayed when "MAP", "Menu", or "DEST" switch pressed. (Screen cannot be switched.)

INSPECTION PROCEDURE

1 Service check mode (Check the navigation ECU)

NG

Troubleshoot for each diagnosis.

OK

Replace multi-display.

Ncon

2 Check the navigation ECU power source circuit ([see page DI-256](#)).

NG

Replace or repair wire harness or connector.

OK

3 Check multi-display power source circuit ([see page DI-259](#)).

NG

Replace or repair wire harness or connector.

OK

4 Check the display signal circuit ([see page DI-270](#)).

NG

Replace or repair wire harness or connector.

OK

Replace multi display.

4. No corresponding screen displayed when "Audio" or "Information" switch pressed.**INSPECTION PROCEDURE**

1 Service check mode (Panel switch check mode screen)

NG

Troubleshoot for each diagnosis.

OK

2 Check AVC-LAN communication circuit (See page DI-275).

NG

Repair or replace AVC-LAN circuit.

OK

Replace the multi display.

5. No navigation displayed, "Audio OFF" on audio screen and no audio sound.

INSPECTION PROCEDURE

1 Service check mode

NG

Troubleshoot for each diagnosis.

OK

2 Check the radio receiver assembly.

PREPARATION:

Disconnect the radio receiver assembly connector.

CHECK:

Check voltage at terminal +B.

OK:

+B: 10 – 14 V

CHECK:

Check voltage at terminal ACC when turning the ignition switch to the ACC or ON position.

OK:

ACC: 10 – 14 V

CHECK:

Check continuity at terminal GND.

OK:

GND: Continuity

NG

Replace or repair wire harness.

OK

3 Check "AVC-LAN communication circuit". (See page DI-275)

NG

Replace the AVC-LAN circuit or radio receiver assembly.

OK

Replace the multi display.

6. Screen cannot be dimmed in night time.

INSPECTION PROCEDURE

- | | |
|----------|---|
| 1 | Check if the screen is dimmed at night. (With the light control switch ON), do all screens except the navigation screen appear in Night Mode?) |
|----------|---|

NG

Check the light control switch.

OK

- | | |
|----------|---------------------------------|
| 2 | Check the multi display. |
|----------|---------------------------------|

CHECK:

Measure the voltage between terminals DR and GND1 of the multi-display.

OK:

DR: Above 9 V

NG

Replace or repair wire harness.

OK

- | | |
|----------|--|
| 3 | Check multi-display power source circuit (see page DI-259). |
|----------|--|

NG

Replace or repair wire harness.

OK

Replace the multi display.

7. Navigation screen not stabilized (Synchronous error).

INSPECTION PROCEDURE

1 Check the navigation ECU power source circuit ([see page DI-256](#)).

NG

Replace or repair wire harness or connector.

OK

2 Check the display signal circuit ([see page DI-259](#)).

NG

Replace or repair wire harness or connector.

OK

Replace the multi-display.

8. Color on navigation screen is unusual (RGB signal error).

INSPECTION PROCEDURE

1 Display check mode (Color bar check).

NG

Replace the multi display.

2 Navigation check mode (Color bar check).

NG

Go to step 4.

OK

3 Check the screen setting. (Day or Night mode)

OK

Normal.

NG

4 Check the navigation ECU power source circuit ([see page DI-256](#)).

NG

Replace or repair wire harness or connector.

OK

5 Check the display signal circuit (see page DI-270).

NG

Replace or repair wire harness or connector.

OK

Replace the multi-display.

9. Black screen appears when "MAP", "Menu" or "DESTINATION" switch pressed.**INSPECTION PROCEDURE**

1 Check the navigation ECU power source circuit ([see page DI-256](#)).

NG

Replace or repair wire harness or connector.

OK

2 Check the display signal circuit ([see page DI-270](#)).

NG

Replace or repair wire harness or connector.

OK

Replace the multi-display.

10. Sound of radio, cassette tape or CD only cannot be heard from speaker.

INSPECTION PROCEDURE

1	Check the radio receiver assembly.
---	------------------------------------

PREPARATION:

Disconnect the radio receiver assembly connector.

CHECK:

Check voltage at terminal +B.

OK:

+B: 10 - 14 V

CHECK:

Check voltage at terminal ACC when turning the ignition to the switch ACC or ON position.

OK:

ACC: 10 - 14 V

CHECK:

Check continuity at terminal GND.

OK:

GND: Continuity

NG

Replace or repair wire harness or connector.

OK

Replace the radio receiver assembly.

11. No sound (radio, cassette tape, DVD) can be heard from driver side door speaker only.

INSPECTION PROCEDURE

1 Service check mode.

NG

Troubleshoot for each diagnosis.

OK

2 Check the navigation system voice.

OK

Go to step 5.

NG

3 Check for open or short in harness and connector between navigation ECU and driver side door speaker (see page DI-265).

NG

Replace or repair wire harness or connector.

OK

4 Check the driver side door speaker.

NG

Replace the speaker.

OK

Replace the navigation ECU.

- | | |
|---|---|
| 5 | Check for open or short in harness and connector between navigation ECU and driver side door speaker (see page DI-265). |
|---|---|

NG

Replace or repair wire harness or connector.

OK

Replace the stereo component amplifier.

12. Map DISC cannot be inserted.

INSPECTION PROCEDURE

1 Check the MAP DISC.

NG

Replace the MAP DISC.

OK

2 Insert a MAP DISC without tilt.

OK

Normal.

NG

3 Check the navigation ECU power source circuit ([see page DI-256](#)).

NG

Replace or repair wire harness.

OK

Replace the navigation ECU.

13. MAP screen display does not appear. (Disc Caution screen does not change)

INSPECTION PROCEDURE

1 Take appropriate measures according to the caution screen.

OK

Normal

NG

2 Check map DISC.

NG

Replace the disc.

OK

Replace the navigation ECU.

CAUTION SCREEN

CAUTION MESSAGE	CAUSE	CORRECTIVE ACTION
The DVD cover is open. Close it and perform operation again.	The cover of the map disk slot is open.	Close the cover.
No DVD. Please insert map DVD.	No map disk is inserted.	Insert a proper map disc.
Unable to read DVD correctly. Check if the DVD is damaged or dirty.	Data cannot be read because the map disc is dirty or scratched.	Wipe off dirt on the both disc surface with soft cloth.
Unable to read data. Check if map DVD is correct.	Something other than map disc is inserted.	Insert a correct map disc.
Unable to read data. Temperature is too high.	Pick-up part of the player is heated to a high temperature.	Stop the vehicle at a shaded cool place and turn the ignition switch OFF. When confirming that the temperature of the navigation ECU has been lowered, turn the ignition switch ON.
Unable to read data. Contact your dealer.	The player cannot read data from the map disc temporarily.	Turn the ignition switch OFF and ON.*1

*1: If the same caution screen appears again after turning the ignition switch ON, replace the navigation ECU.

14. Map is displayed in white or blue screen. (Switches and vehicle position mark are displayed)

INSPECTION PROCEDURE

1 Set the map scale to the max.

OK

Normal

HINT:

Correct the current position and check it again.

NG

2 Wipe the disc with a soft cloth, insert it again, and turn the ignition switch ON from OFF.

NG

Replace the disc.

OK

Normal

HINT:

If the trouble still occurs, replace the navigation ECU.

15. Touch switch does not function. (Navigation screen only)**INSPECTION PROCEDURE**

1 Display check mode (Touch switch check screen)

NG

Replace the multi-display.

OK

2 Check "AVC-LAN communication circuit". (See page DI-275)

NG

Replace or repair AVC-LAN circuit.

OK

Replace the navigation ECU.

16. Touch switch does not function. (A/C control screen only)**INSPECTION PROCEDURE**

1 Display check mode (Touch switch check screen)

NG

Replace the multi-display.

OK

2 Check "AVC-LAN communication circuit". (See page DI-275)

NG

Replace or repair AVC-LAN circuit.

OK

3 Check wire harness between gateway ECU and A/C amplifier (Center ECU) (See page IN-38)

NG

Repair or replace wire harness and connector.

OK

Check and replace A/C amplifier (Center ECU).

17. Panel switch does not function. (Navigation screen only)**INSPECTION PROCEDURE**

1 Display check mode (Panel switch check screen)

NG

Replace the multi display.

OK

2 Check "AVC-LAN communication circuit". (See page DI-275)

NG

Replace or repair AVC-LAN circuit.

OK

Replace the navigation ECU.

18. Panel Switch Does Not Function (A/C control only)

INSPECTION PROCEDURE

1 Display check mode (Panel Switch Check screen)

NG

Replace the multi display.

OK

2 Check "AVC-LAN communication circuit" (See page DI-275).

NG

Replace or repair AVC-LAN circuit.

OK

3 Check wire harness and connector between gateway ECU and A/C amplifier (Center ECU) (See page IN-38).

NG

Repair or replace wire harness and connector.

OK

Check and replace A/C amplifier (Center ECU).

19. Navigation screen cannot change to the night mode color.

INSPECTION PROCEDURE

1 Check the setting. (Is it set to Day Mode in screen adjustment?)

Yes

Normal

No

2 Check if the screen is dimmed at night. (With the light control switch ON, do all screens except the navigation screen appear in Night Mode?)

NG

Go to step 5.

OK

3 Does the beep sound by operating switches on the navigation screen?

OK

Replace the navigation ECU.

NG

4 Check "AVC-LAN communication circuit". (See page DI-275)

NG

Replace or repair AVC-LAN circuit.

OK

Replace the navigation ECU.

5	Check the multi display.
----------	---------------------------------

CHECK:

Measure the voltage between terminal DR and GND1 of the multi-display.

OK:**DR: Above 9 V**

OK	Replace the multi display.
-----------	-----------------------------------

NG

Replace or repair wire harness.
--

20. Vehicle position is deviated from correct point badly.

INSPECTION PROCEDURE

1 Check the mark display. (At a place with a fine view, is GPS mark displayed or not?)

No

Go to step 7.

Yes

2 Does the trouble occur in the specific area or not?

Yes

Normal (If the vehicle is positioned in the place where it is difficult to be identified, the current vehicle position may be incorrectly displayed.)

No

3 Check the setting (Color of the automatic calibration button on the calibration screen).

Green

Normal (Drive the vehicle (10 km or more) until calibration is completed.)

Blue

4 Service check mode (Is "58-43" displayed in the unit check mode of the navigation ECU?)

Yes

Troubleshoot for each diagnosis.

No

5 Navigation check mode (vehicle signal check mode: SPD)

NG

Replace or repair speed sensor wire harness.

OK

6 Recurrence Test (Confirm the phenomenon) (Correct the current position and drive the vehicle for a while with the GPS mark displayed)

OK

Normal

NG

Replace the navigation ECU.

7 Check if the harness is caught or sharply bent or not.

NG

Navigation antenna is surely connected.

OK

8 Check optional components. (Does it become normal if the optionals such as the theft deterrent system is removed?)

Yes

Remove or change the position of the components.

HINT:

Some optionals receive radio signals, and if this happens, GPS reception may be affected.

No

9 Is there anything such as a film stuck to the window?

Yes

Reception may be affected by a screen such as a film.

No

10 Service check mode (Is "80-40, 41" displayed in the unit check mode of the navigation ECU?)

Yes

Troubleshoot for each diagnosis.

No

Replace the navigation antenna.

HINT:

If the trouble still occurs, replace the navigation ECU.

21. GPS mark does not appear.**INSPECTION PROCEDURE**

- | | |
|----------|---|
| 1 | Check the mark display. (At a place with a fine view, is GPS mark displayed or not?) |
|----------|---|

Yes**Normal****No**

- | | |
|----------|---|
| 2 | Check if the harness is caught or sharply bent or not. |
|----------|---|

NG**Navigation antenna is surely connected.****OK**

- | | |
|----------|---|
| 3 | Check optional components. (Does it become normal if the optionals such as the theft deterrent system is removed?) |
|----------|---|

Yes**Remove or change the position of the components.****HINT:**

Some optionals receive radio signals, and if this happens, GPS reception may be affected.

No

4 Is there anything such as a film stuck to the window?

Yes

Reception may be affected by a screen such as a film.

No

5 Service check mode (Is "80-40, 41" displayed in the unit check mode of the navigation ECU?)

Yes

Troubleshoot for each diagnosis.

No

Replace the navigation antenna.

HINT:

If the trouble still occurs, replace the navigation ECU.

22. No voice navigation.

INSPECTION PROCEDURE

- | | |
|---|---|
| 1 | Set the volume to the max in the menu screen. |
|---|---|

OK

Normal (Voice navigation is not available. No destination is set, or the vehicle is running off the route.)

NG

- | | |
|---|---|
| 2 | Check for open or short in harness and connector between navigation ECU and driver side door speaker (see page DI-265). |
|---|---|

NG

Replace or repair wire harness.

OK

- | | |
|---|---|
| 3 | Check the sound. (Check if the radio sound can be heard from the driver side door speaker.) |
|---|---|

OK

Replace the navigation ECU.

NG

Replace the speaker.

23. Vehicle position rotates without control. (Map rotates without control)

INSPECTION PROCEDURE

- | | |
|---|--|
| 1 | Recheck. (While not rotating the vehicle, turn the ignition switch ON from OFF again.) |
|---|--|

OK

Normal (While the vehicle was turning, the ignition switch was turned ON.)

NG

- | | |
|---|--|
| 2 | System check mode (Is "58-10" displayed in the unit check mode of the navigation ECU?) |
|---|--|

Yes

Replace the navigation ECU.

No

- | | |
|---|--|
| 3 | System check mode (Is "58-43" displayed in the unit check mode of the navigation ECU?) |
|---|--|

Yes

Replace and repair SPD terminal wire harness.

No

- | | |
|---|---|
| 4 | Navigation check mode (vehicle signal check mode: SPD and gyro) |
|---|---|

OK

Replace the navigation ECU.

NG

Replace or repair wire harness.

24. Driving direction is opposite to moving direction of vehicle position mark.**INSPECTION PROCEDURE**

1 Navigation check mode (vehicle signal check mode REV)

OK

Replace the navigation ECU.

NG

2 Check the reverse signal circuit of navigation ECU (see page DI-273).

OK

Replace the navigation ECU.

NG

Replace or repair wire harness.

25. Navigation system cannot be operated with voice recognition.

INSPECTION PROCEDURE

1 Check microphone.

NG

Replace microphone (See page IN-38).

OK

2 Check overhead J/B.

NG

Replace overhead J/B (See page IN-38).

OK

3 Check wire harness between overhead J/B (microphone) and navigation ECU.

PREPARATION:

Disconnect the overhead J/B and navigation ECU connectors.

CHECK:

Check continuity of the wire harness between terminals of the overhead J/B and those of the navigation ECU.

OK:

Continuity

NG

Replace or repair wire harness or connector.

OK

Check and replace navigation ECU.

26. Cellular Phone Registration Failure, Phone Directory Transfer Failure

INSPECTION PROCEDURE

1 Check cellular phone.

(a) Check by following the conditions below.

Conditions	See page
Another BLUETOOTH capable cellular phone is present.	A
Another BLUETOOTH capable vehicle is present.	B
None of the above	C

B

Go to step 3

C

Go to step 4

A

2 Check using another cellular phone.

(a) Check if the system functions using another BLUETOOTH capable cellular phone.

OK:

The system functions.

NG

Go to step 4

OK

Use a capable bluetooth capable cellular phone (Depending on the version, some bluetooth capable cellular phones cannot be used)

3	Check using another bluetooth capable vehicle.
----------	---

(a) Check if the cellular phone is BLUETOOTH capable.

OK:

The system functions.

OK

Replace multi-display.

NG

4	Check cellular phone.
----------	------------------------------

(a) Check if the cellular phone is BLUETOOTH capable.

HINT:

Some version of BLUETOOTH capable cellular phone may not function.

OK:

The phone is BLUETOOTH capable.

NG

Use a bluetooth capable cellular phone.

OK

5	Check cellular phone.
----------	------------------------------

(a) Check if the cellular phone can call.

HINT:

When the battery charge is low, registration or directory transfer cannot be performed.

OK:

The cellular phone can call.

NG

Replace cellular phone.

OK

Replace multi-display.

27. The Cellular Phone cannot Send/Receive

INSPECTION PROCEDURE

1 Check bluetooth settings.

Check if the BLUETOOTH settings are correct.

OK:

BLUETOOTH settings are correct.

NG

Set settings correctly.

OK

2 Check cellular phone.

Check if the cellular phone is BLUETOOTH capable.

HINT:

Some versions of BLUETOOTH capable cellular phone may not be compatible.

OK:

The phone is BLUETOOTH capable.

NG

END (Only a bluetooth capable cellular phone can be used)

OK

3 Check settings

Check if the cellular phone functions.

HINT:

- The cellular phone is unable to call under any of the following conditions.
- The cellular phone is locked.
- The directory is being transferred.
- The line is crossed.
- Transmission is requested.
- The power is off.
- The cellular phone is not connected to BLUETOOTH ("BT" is displayed while a connection is present).

OK:

No of the above conditions exist.

NG

Set setting correctly.

OK

4 Check cellular phone.

Check if the cellular phone can call.

HINT:

When the battery charge is low, calls cannot be made or received.

OK:

The cellular phone can call.

NG

Replace cellular phone.

OK

5 Check reception

- (a) Put a cellular phone into a receiving state.
- (b) Place the cellular phone close to the multi-display.
- (c) Check if the cellular phone has reception according to the multi-display.

OK:

The cellular phone has reception.

NG**Replace multi-display.****OK**

Go to "Own voice cannot be heard, quiet or distorted" ([See page DI-254](#))

28. Cannot Call in a Certain Place

INSPECTION PROCEDURE

1 Check surrounding conditions.

Check if a cellular phone can make calls in a certain place.

OK:

It can make calls.

NG

END (Cellular phones can only function in cellular service areas).

OK

2 Check reception

Check if the reception level is the same on a cellular phone and the multi-display.

OK:

The reception level is different.

NG

Replace multi-display.

OK

3 Check reception

NG

Replace multi-display.

OK

END (Multi-display receives the different strength of radio wave depending on the radio waves strength transmitted by cellular phone)

29. Voice on Phone Cannot be Heard, too Quiet, or Distorted

INSPECTION PROCEDURE

1 Check cellular phone.

Check if the voice on the other side can be heard using a cellular phone.

OK:

Voice can be heard.

NG

Replace cellular phone.

OK

2 Check settings

(a) Check if the volume is set to the minimum or maximum setting.

HINT:

When the volume is set to the minimum or maximum setting, the sound may be distorted.

(b) Check if the MUTE switch is set to ON.

OK:

MUTE switch is not set to ON.

NG

Set mute switch correctly.

OK

3 Voice check

Check if the navigation voice can be heard.

OK:

The voice can be heard.

NG

**Go to "No voice navigation"
(See page DI-242).**

OK

Replace multi-display.

30. Own Voice Cannot be Heard, Quiet or Distorted

CIRCUIT DESCRIPTION

1 Check cellular phone.

Check if the other side can hear your voice properly.

OK:

Own voice can be heard correctly.

NG

Replace cellular phone

OK

2 Check settings

Check if the mute switch is set to ON.

OK:

MUTE switch is not set to ON.

NG

Turn the mute switch off.

OK

3 Navigation check mode (Microphone check)

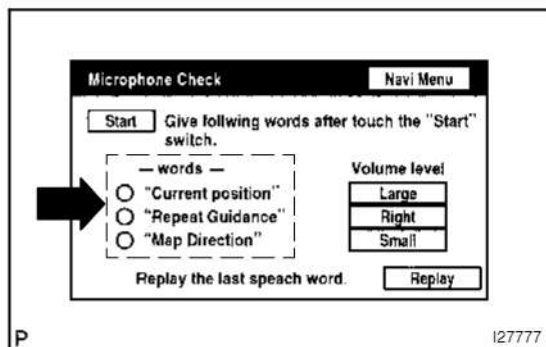

- (a) Enter the "Microphone Check" mode (see page DI-175).
- (b) Follow the directions on the screen. Check if the word recognition indicator is displayed in green each item.

NG

Go to "Navigation system cannot be operated with voice recognition."

OK

Replace multi-display

Power Source Circuit (Navigation ECU)

CIRCUIT DESCRIPTION

This circuit is the power source circuit to operate the navigation ECU.

WIRING DIAGRAM

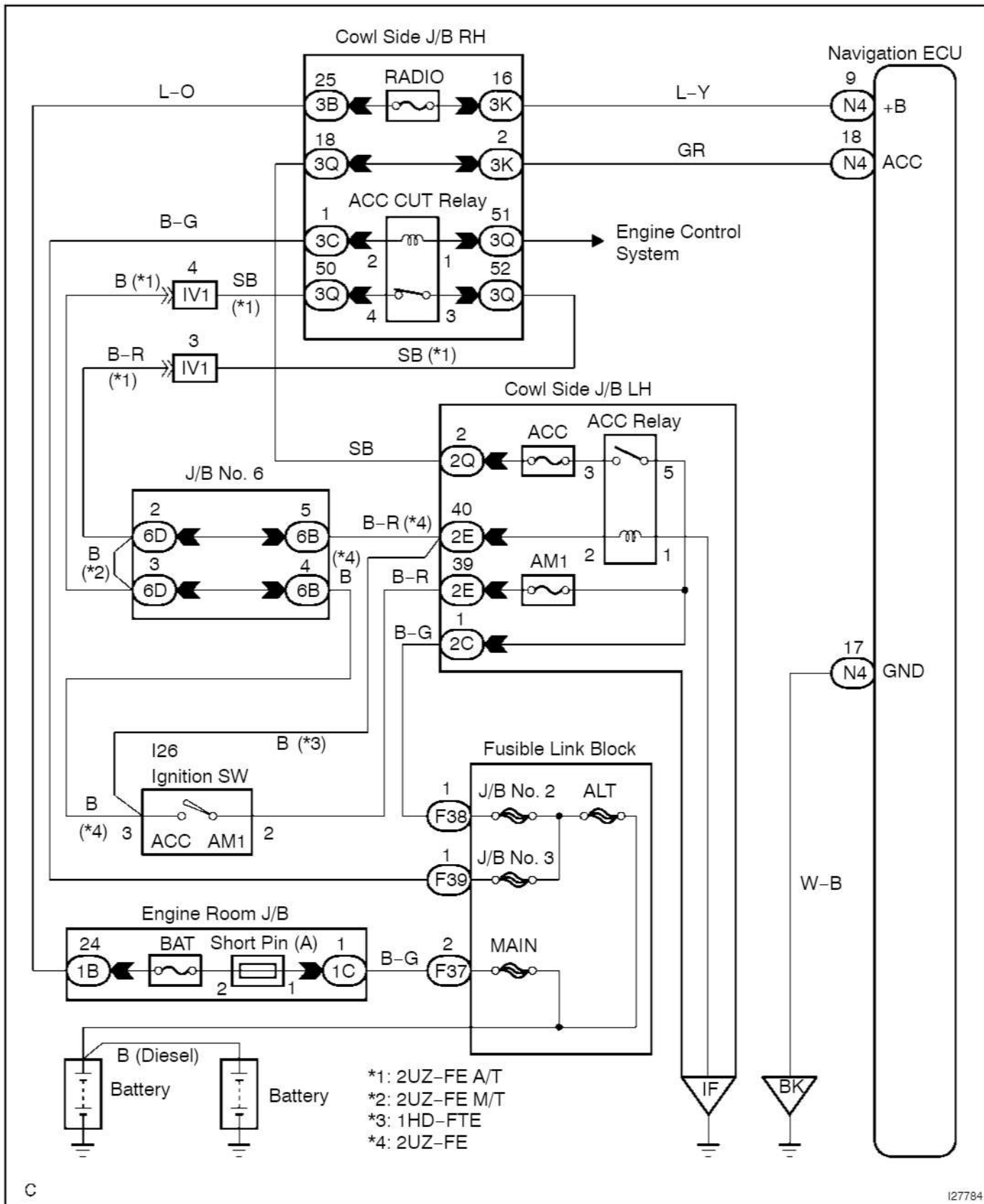

C

127784

INSPECTION PROCEDURE

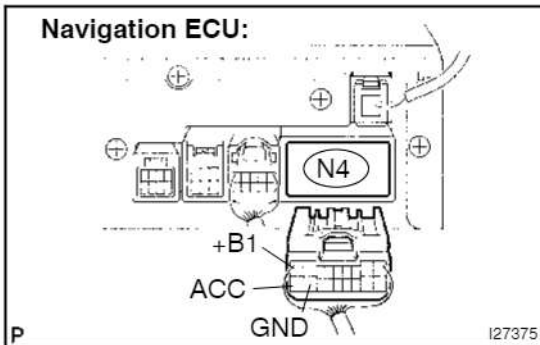
1 Check voltage between terminals +B1, ACC and GND of navigation ECU.

- (a) Disconnect the connector from the navigation ECU.
 (b) Measure the voltage according to the value(s) in the table below.

Standard:

Tester connection	Condition	Specified condition
+B1 - GND	Always	10 to 14 V
ACC - GND	Ignition SW ACC	10 to 14 V

OK

Proceed to next circuit inspection shown in problem symptoms table. (See page DI-209)

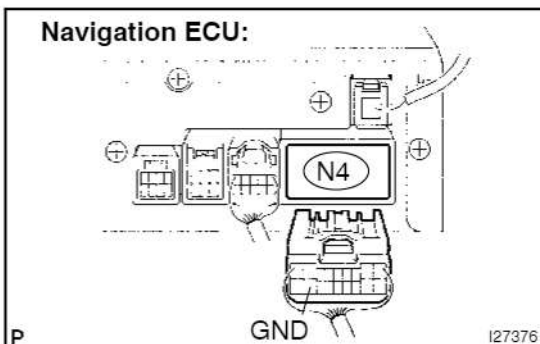
NG**2 Check continuity between terminal GND of navigation ECU and body ground.**

- (a) Disconnect the connector from the navigation ECU.
 (b) Measure the resistance according to the value(s) in the table below.

Standard:

Tester connection	Condition	Specified condition
GND - Body ground	Always	Below 1 Ω

OK

Repair or replace harness or connector between navigation ECU and fuse.

NG

Repair or replace harness or connector between navigation ECU and body ground.

Power Source Circuit (Multi-Display Assembly)

CIRCUIT DESCRIPTION

This circuit is the power source circuit to operate the multi-display assembly.

WIRING DIAGRAM

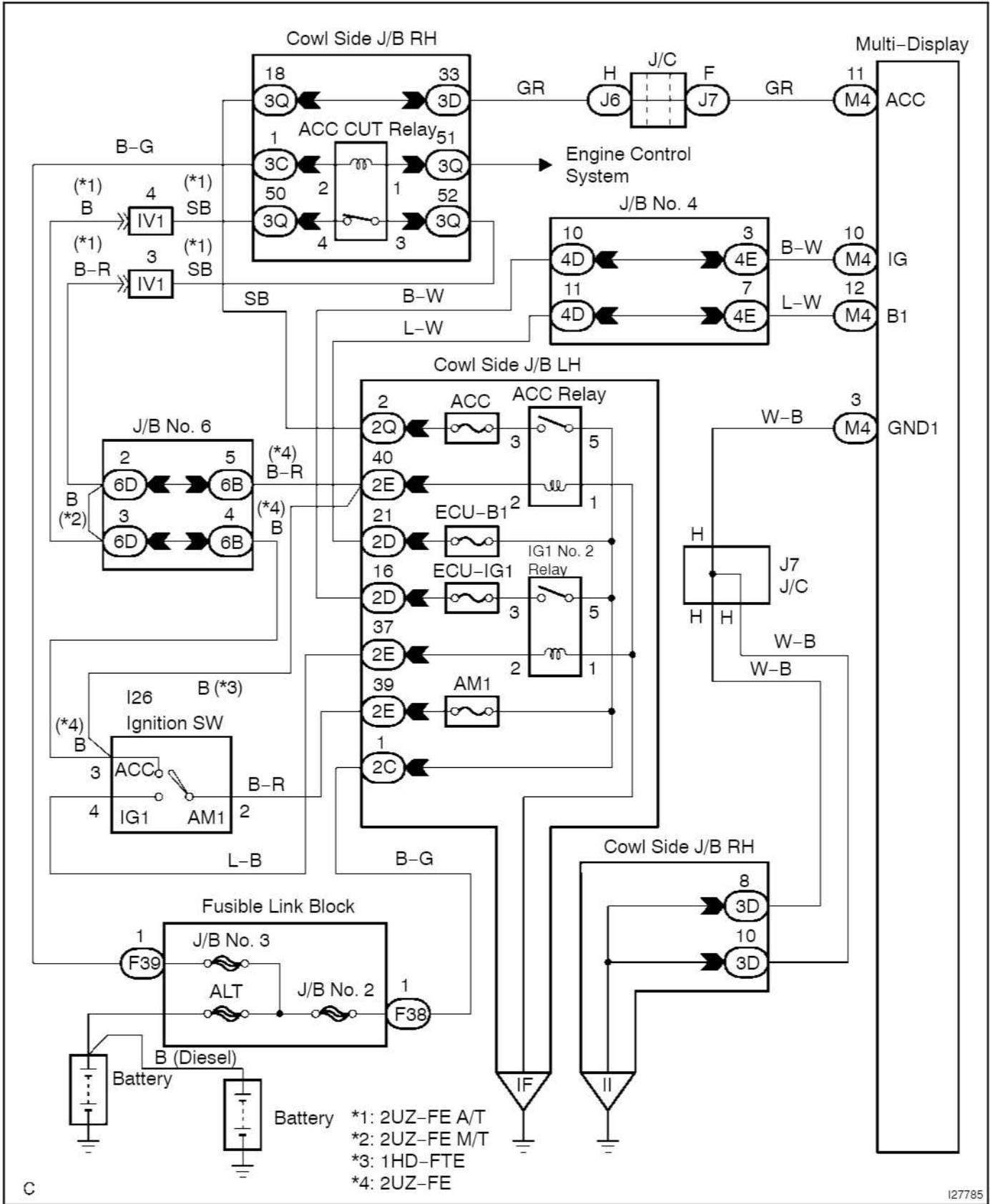

cardiagn.com

INSPECTION PROCEDURE

- 1 Check voltage between terminals B1, ACC, IG and GND of multi-display assembly.**

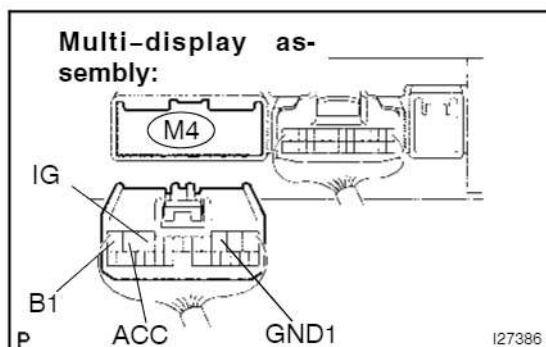

- (a) Disconnect the connector from the multi-display assembly.
 (b) Measure the voltage according to the value(s) in the table below.

Standard:

Tester connection	Condition	Specified condition
B1 - GND1	Always	10 to 14 V
ACC - GND1	Ignition SW ACC	10 to 14 V
IG - GND1	Ignition SW ON	10 to 14 V

OK

Proceed to next circuit inspection shown in problem symptoms table. (See page DI-209)

NG

- 2 Check continuity between terminal GND1 of multi-display assembly and body ground.**

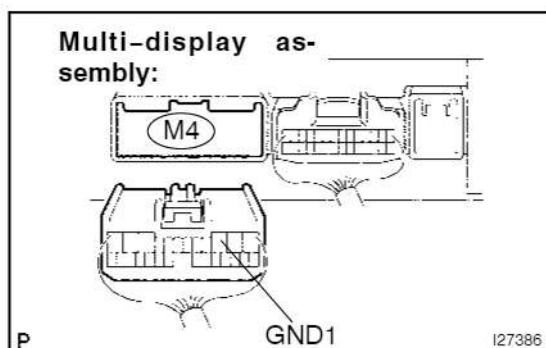

- (a) Disconnect the connector from the multi-display assembly.
 (b) Measure the resistance according to the value(s) in the table below.

Standard:

Tester connection	Condition	Specified condition
GND1 - Body ground	Always	Below 1 Ω

OK

Repair or replace harness or connector between navigation ECU and fuse.

NG

Repair or replace harness or connector between navigation ECU and body ground.

Power Source Circuit (Network Gateway ECU)

CIRCUIT DESCRIPTION

This circuit is the power source circuit to operate the network gateway ECU.

WIRING DIAGRAM

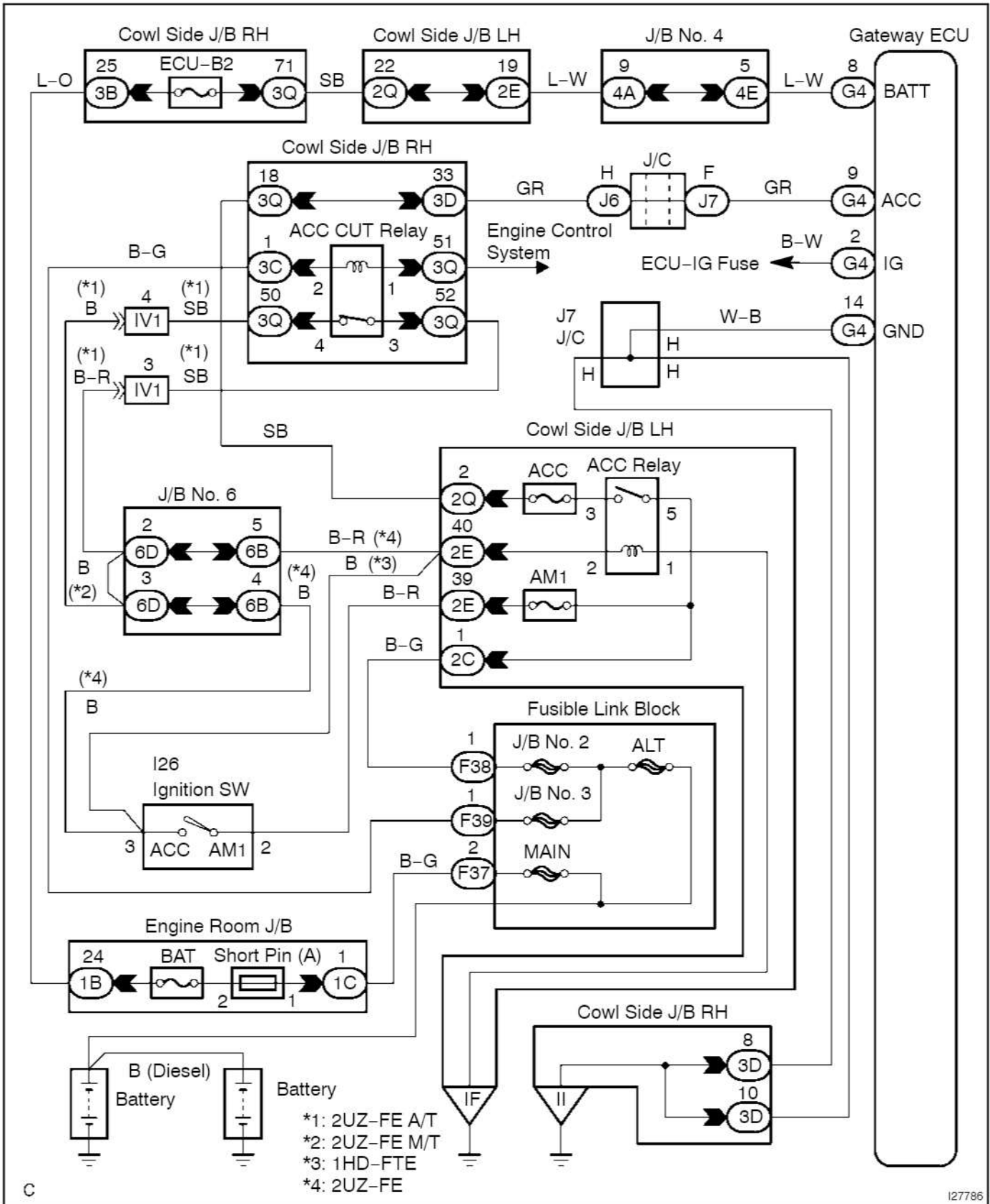

cardiagn.com

INSPECTION PROCEDURE

- 1 Check voltage between terminals +BATT, ACC, IG and GND of network gateway ECU.

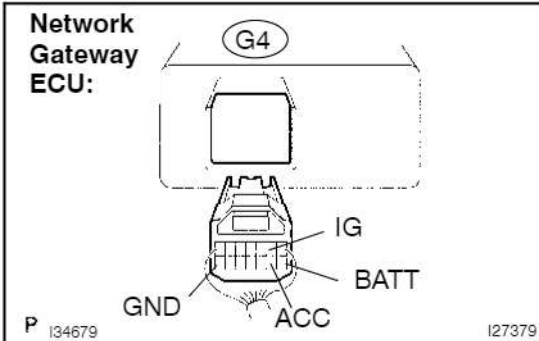

- (a) Disconnect the connector from the network gateway ECU.
 (b) Measure the voltage according to the value(s) in the table below.

Standard:

Tester connection	Condition	Specified condition
BATT – GND	Always	10 to 14 V
ACC – GND	Ignition SW ACC	10 to 14 V
IG – GND	Ignition SW ON	10 to 14 V

OK

Proceed to next circuit inspection shown in problem symptoms table. (See page DI-209)

NG

- 2 Check continuity between terminal GND of network gateway ECU and body ground.

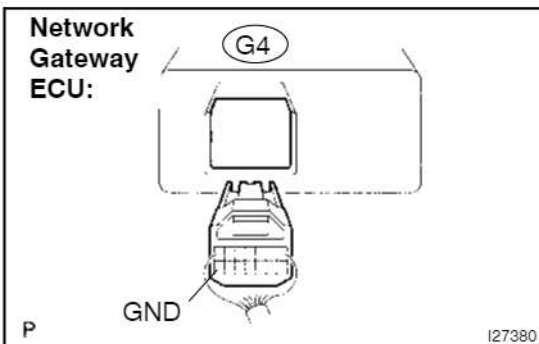

- (a) Disconnect the connector from the network gateway ECU.
 (b) Measure the resistance according to the value(s) in the table below.

Standard:

Tester connection	Condition	Specified condition
GND – Body ground	Always	Below 1 Ω

OK

Repair or replace harness or connector between navigation ECU and fuse.

NG

Repair or replace harness or connector between navigation ECU and body ground.

INSPECTION PROCEDURE

1	Inspect apparatus.
----------	---------------------------

(a) Choose the apparatus to be inspected.

Apparatus	Go to step
Front LH speaker	A
Front LH tweeter	B
Front speaker No.1 assy and front speaker No.2 assy	C

B → **Go to step 4**

C → **Go to step 5**

A

2	Inspect front LH speaker.
----------	----------------------------------

(a) Disconnect the speaker connector.

(b) Resistance check.

(1) Measure the resistance between the terminals of the speaker.

NOTICE:

The speaker should not be removed for checking.

Standard value:

Approx. 2 Ω

NG → **Replace front LH speaker.**

OK

3 Check for open or short circuit in harness and connector between front LH speaker and front LH tweeter.

Front Door Speaker Side:

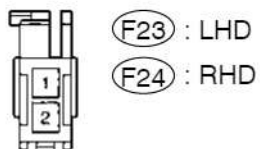

Front Tweeter Side:

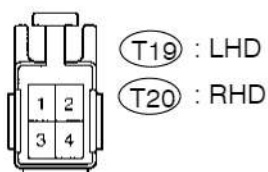

P

I27393

- (a) Disconnect the front No.2 speaker connector.
- (b) Measure the resistance according to the value(s) in the table below.

Standard:

Tester connection	Condition	Specified condition
F23(24)-1 - T19(20)-3	Always	Below 1 Ω
F23(24)-2 - T19(20)-1	Always	Below 1 Ω
F23(24)-1 - Body ground	Always	10 k Ω or higher
F23(24)-2 - Body ground	Always	10 k Ω or higher

NG

Repair or replace harness or connector.

OK

Proceed to next circuit inspection shown in problem symptoms table. (See page DI-209)

4 Check for open or short circuit in harness and connector between navigation ECU and stereo component amplifier assembly.

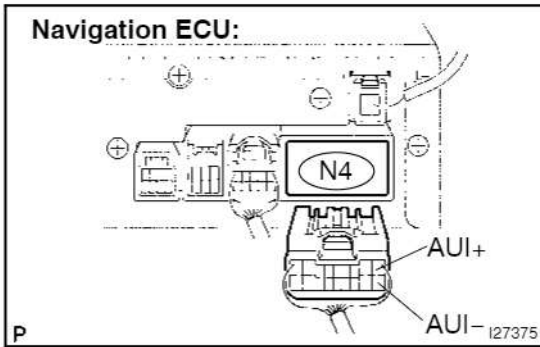

- (a) Disconnect the connector from the navigation ECU and stereo component amplifier assembly.
- (b) Measure the resistance according to the value(s) in the table below.

Standard:

Tester connection	Condition	Specified condition
AUI+ - FL+	Always	Below 1 Ω
AUI- - FL-	Always	Below 1 Ω
AUI+ - Body ground	Always	10 k Ω or higher
AUI- - Body ground	Always	10 k Ω or higher

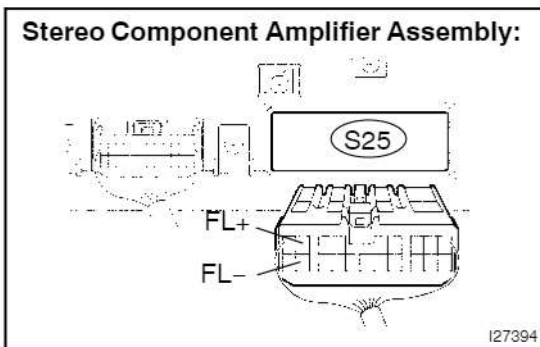

NG

Repair or replace harness or connector.

OK

5 Inspect stereo component amplifier assembly.

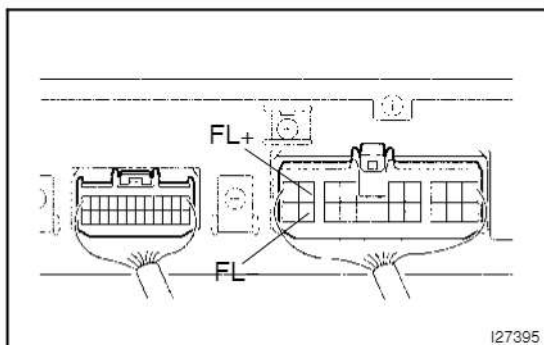

- (a) Connect the connector.
- (b) Using an oscilloscope, check the signal waveform between the terminals according to the conditions, as shown in the chart.

Standard:

Tester connection	Condition	Specified condition
FL+ - Body ground	While voice sound is being produced	A waveform synchronized with sound is output
FL- - Body ground	While voice sound is being produced	A waveform synchronized with sound is output

NG

Replace stereo component amplifier assembly.

OK

Proceed to next circuit inspection shown in problem symptoms table. (See page DI-209)

Display Signal Circuit

CIRCUIT DESCRIPTION

This is the display signal circuit from the multi-display controller sub-assy to the multi-display assy.

WIRING DIAGRAM

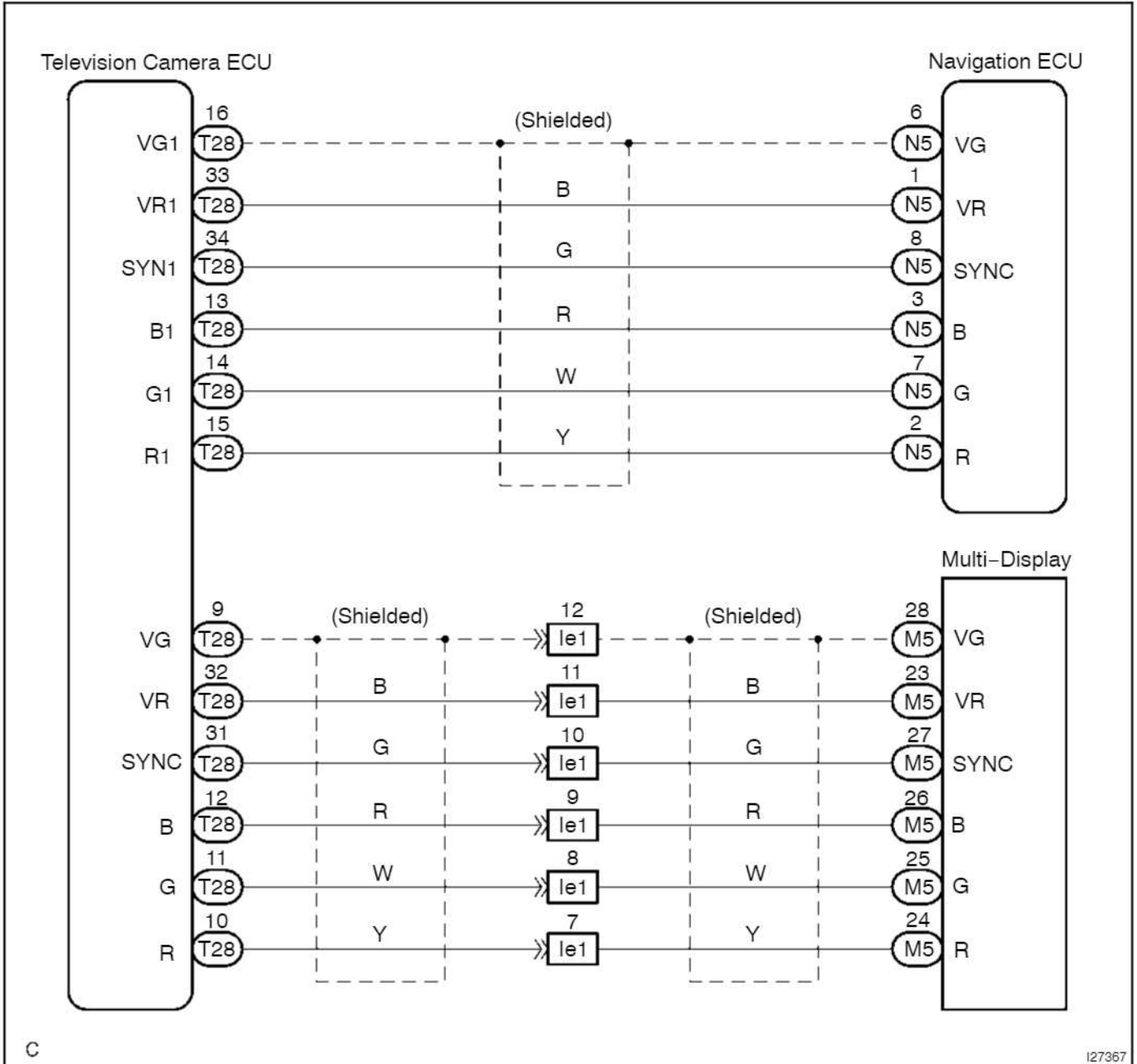

C

I27367

INSPECTION PROCEDURE

- 1 Check for open or short circuit in harness and connector between navigation ECU and television camera ECU.

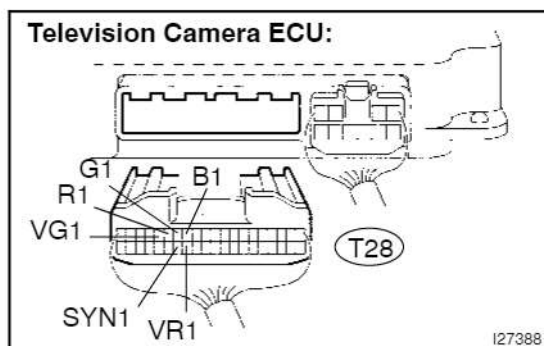
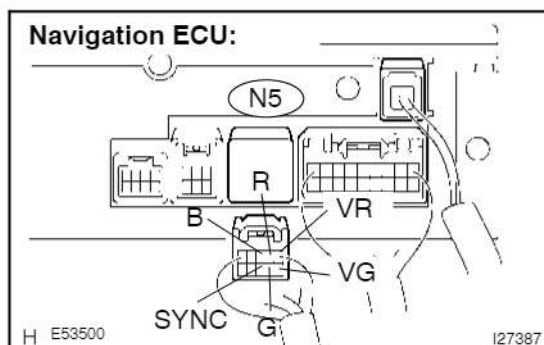

- (a) Disconnect the connector from navigation ECU and television camera ECU.
 (b) Measure the resistance according to the value(s) in the table below.

Standard:

Tester connection	Condition	Specified condition
R - R1	Always	Below 1 Ω
G - G1	Always	Below 1 Ω
B - B1	Always	Below 1 Ω
SYNC - SYN1	Always	Below 1 Ω
VR - VR1	Always	Below 1 Ω
VG - VG1	Always	Below 1 Ω
R - Body ground	Always	10 k Ω or higher
G - Body ground	Always	10 k Ω or higher
B - Body ground	Always	10 k Ω or higher
SYNC - Body ground	Always	10 k Ω or higher
VR - Body ground	Always	10 k Ω or higher

NG**Repair or replace harness or connector.****OK**

2 Check for open or short circuit in harness and connector between television camera ECU and multi-display assembly.

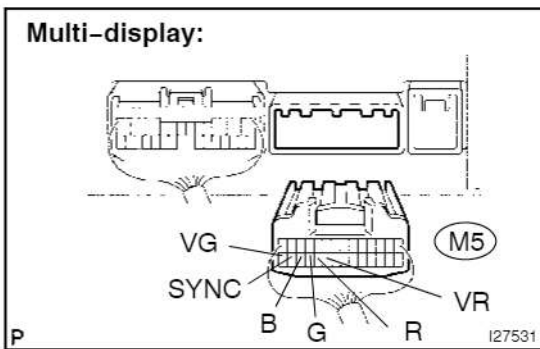
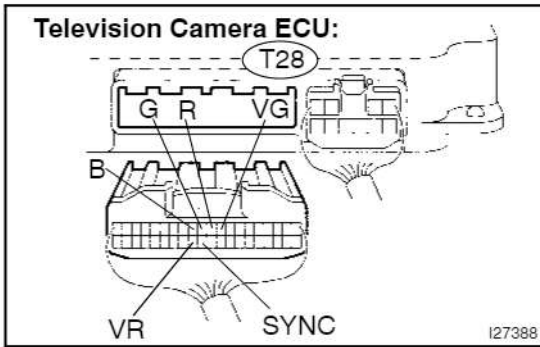

- Disconnect the connector from the television camera ECU and multi-display assy.
- Measure the resistance according to the value(s) in the table below.

Standard:

Tester connection	Condition	Specified condition
R - R	Always	Below 1 Ω
G - G	Always	Below 1 Ω
B - B	Always	Below 1 Ω
SYNC - SYNC	Always	Below 1 Ω
VR - VR	Always	Below 1 Ω
VG - VG	Always	Below 1 Ω
R - Body ground	Always	10 k Ω or higher
G - Body ground	Always	10 k Ω or higher
B - Body ground	Always	10 k Ω or higher
SYNC - Body ground	Always	10 k Ω or higher
VR - Body ground	Always	10 k Ω or higher

NG

Repair or replace harness or connector.

OK

Proceed to next circuit inspection shown in problem symptoms table. (See page DI-209)

Reverse Signal Circuit

CIRCUIT DESCRIPTION

The navigation ECU receives the reverse signal from the park/neutral position switch and information about the GPS antenna, and then adjusts the vehicle position.

WIRING DIAGRAM

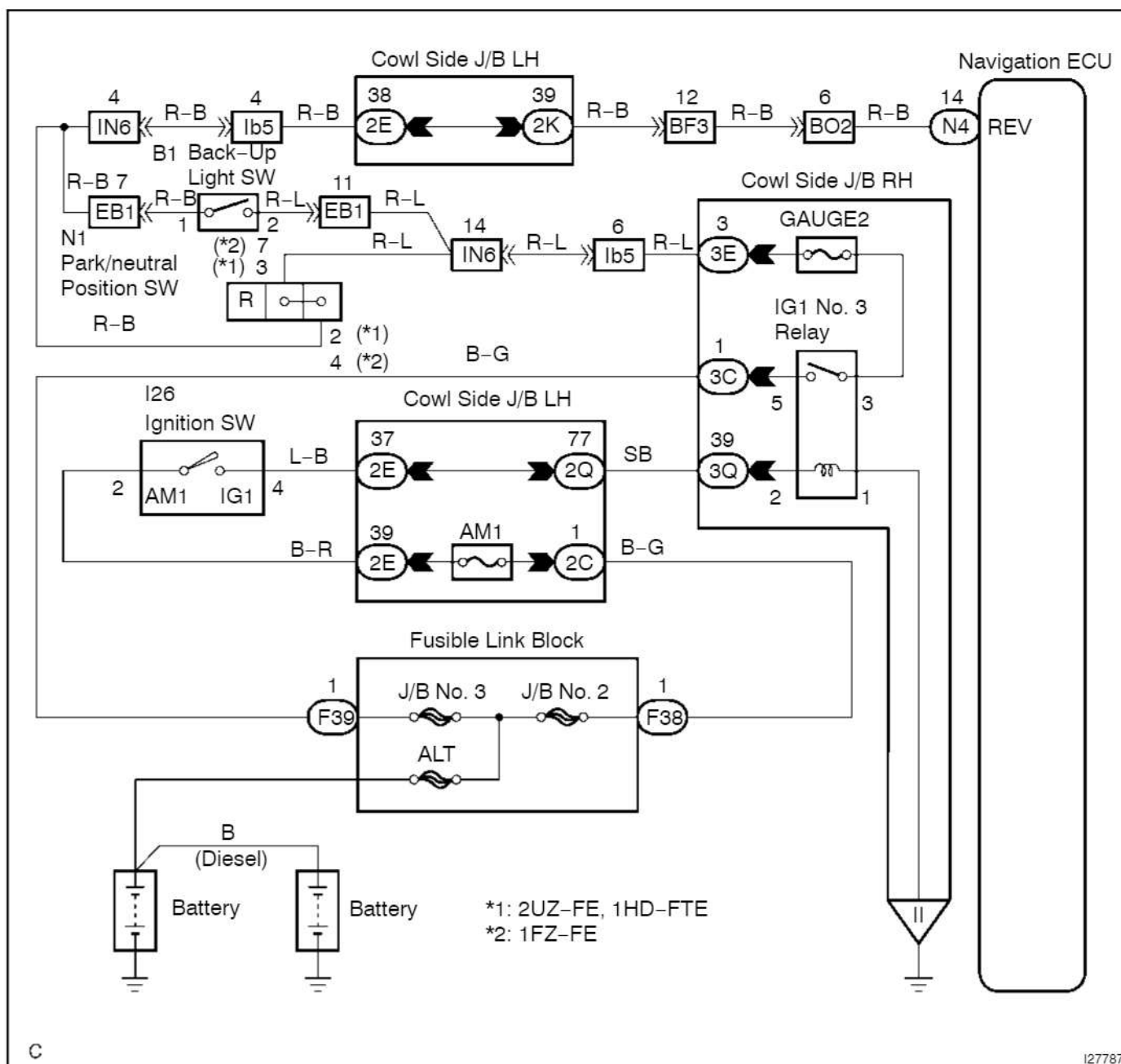

INSPECTION PROCEDURE

1	Check voltage between terminals REV and of navigation ECU and body ground.
----------	---

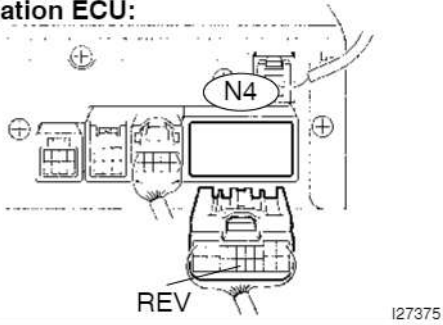
Navigation ECU:

- (a) Measure the voltage according to the value(s) in the table below.

Standard:

Tester connection (Terminal No.)	Condition	Specified condition
REV - Body ground	IG SW ON, shift lever R position	10 to 14 V

OK

Proceed to next circuit inspection shown in problem symptoms table. (See page DI-209)

NG

2	Check for open or short circuit in harness and connector between navigation ECU and park/neutral position switch (A/T) or back-up light switch (M/T) assembly.
----------	---

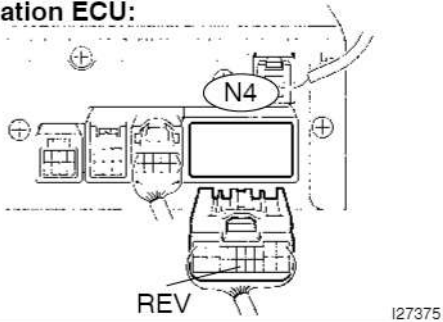
Navigation ECU:

- (a) Disconnect the connector from the navigation ECU.
 (b) Measure the resistance according to the value(s) in the table below.

Standard:**A/T (2UZ-FE, 1HD-FTE):**

Tester connection	Condition	Specified condition
REV - N1-2	Always	Below 1 Ω
REV - Body ground	Always	10 kΩ or higher

A/T (1FZ-FE):

Tester connection	Condition	Specified condition
REV - N1-4	Always	Below 1 Ω
REV - Body ground	Always	10 kΩ or higher

M/T:

Tester connection	Condition	Specified condition
REV - B1-1	Always	Below 1 Ω
REV - Body ground	Always	10 kΩ or higher

OK

Replace park/neutral position switch assembly.

NG

Repair or replace harness or connector.

AVC-LAN (Communication bus) Circuit

CIRCUIT DESCRIPTION

Each unit of navigation system connected with AVC-LAN (communication bus) transfers the signal of each switch by communication.

When +B short and GND short occur in this AVC-LAN, navigation system will not function normally as the communication is discontinued.

In this AVC-LAN, multi display becomes the master of the communication, and the radio receiver assembly has a terminator necessary for transmitting the communication.

The multi display is connected between navigation ECU and radio receiver assembly, and navigation system has the structure that makes communication impossible without navigation ECU, multi display or radio receiver assembly.

AVC-LAN

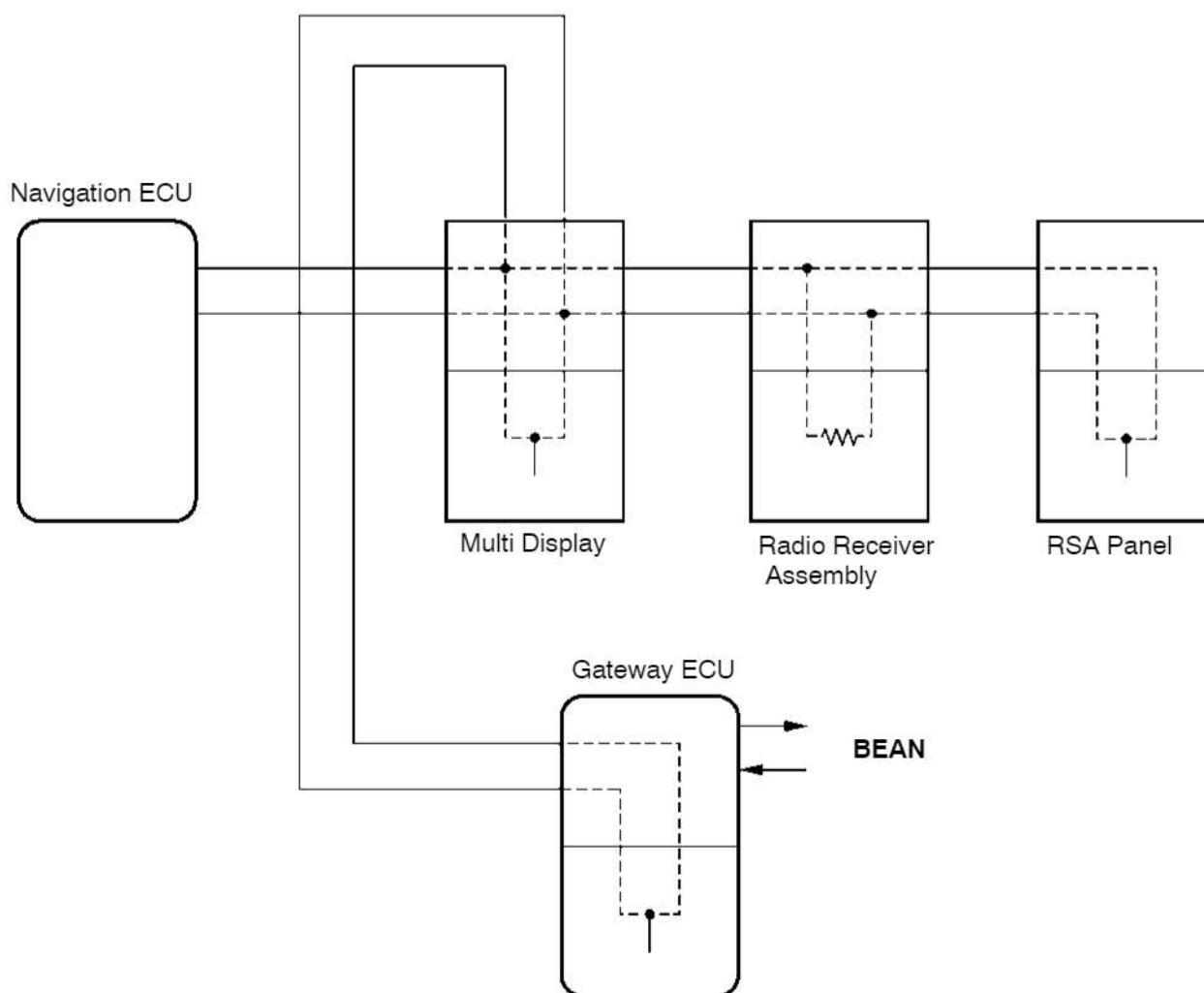

WIRING DIAGRAM

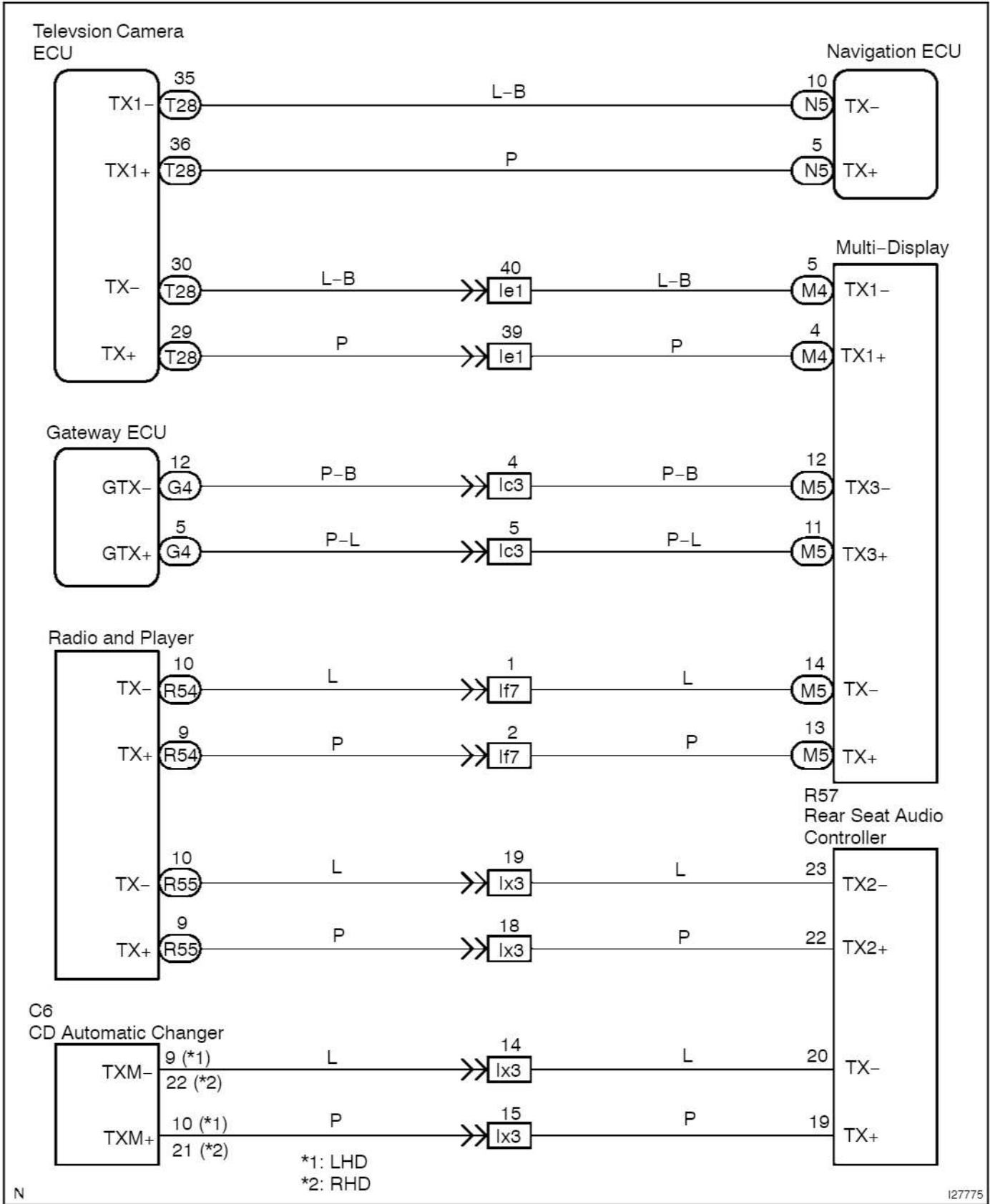

cardiagn.com

INSPECTION PROCEDURE

- | | |
|----------|---|
| 1 | Disconnect the connector "R39" of RSA panel and check if AVC-LAN will be recovered normally. |
|----------|---|

CHECK:

Check that the display will change by pressing either of the Panel switch or Touch switch on the display.

HINT:

It can be judged that AVC-LAN is recovered if the display is changed.

OK

Replace the RSA panel.

NG

- | | |
|----------|---|
| 2 | Check wire harness and connector between radio receiver assembly and RSA panel (See page IN-38). |
|----------|---|

NG

Repair or replace wire harness or connector.

OK

- | | |
|----------|--|
| 3 | Disconnect the "N3" connector of the navigation ECU, check if AVC-LAN will be recovered normally. |
|----------|--|

CHECK:

Check that the display will change by pressing either of the Panel switch or Touch switch on the display.

HINT:

It can be judged that AVC-LAN is recovered if the display is changed.

OK

Replace the stereo navigation ECU.

NG

- | | |
|----------|--|
| 4 | Check wire harness and connector between navigation ECU and multi-display (See page IN-38). |
|----------|--|

NG

Repair or replace wire harness or connector.

OK

- | | |
|----------|--|
| 5 | Disconnect the connector "G4" of gateway ECU and check if AVC-LAN will be recovered normally. |
|----------|--|

CHECK:

Check that the display will change by pressing either of the Panel switch or Touch switch on the display.

HINT:

It can be judged that AVC-LAN is recovered if the display is changed.

OK

Replace the gateway ECU.

NG

- | | |
|----------|--|
| 6 | Check wire harness and connector between multi display and gateway ECU.
(See page IN-38) |
|----------|--|

NG

Repair or replace wire harness or connector.

OK

- | | |
|----------|--|
| 7 | Skip multi display and check AVC-LAN. |
|----------|--|

PREPARATION:

- (a) Connect all the connectors except "M5" and "M6" of the multi display.
- (b) Using 2 SST (Diagnosis check wire P/N 09893-12040), connect the terminal TX1+ of connector "M5" and TX+ of connector "M6", the terminal TX1- of connector "M5" and TX- of connector "M6" respectively of multi-display.

CHECK:

Operate audio head unit (CD, Cassette tape, etc.) and check that the sound comes out from the speaker. (Check that AVC-LAN is recovered.)

OK

Replace the multi display.

NG

8	Skip television camera ECU and check AVC-LAN.
----------	--

PREPARATION:

- (a) Connect multi display connector.
- (b) Disconnect the connector "T21" of the television camera ECU.
- (c) Using SST (Diagnosis check wire P/N 09893-12040), connect the terminal TX1+ and TX+ of connector "T21", the terminal TX- of connector and TX1- of connector "T21" respectively of multi-display.

CHECK:

Operate audio head unit (CD, Cassette tape, etc.) and check that the sound comes out from the speaker. (Check that AVC-LAN is recovered.)

OK	Replace the television camera ECU.
-----------	---

NG

9	Skip Audio head unit and check AVC-LAN.
----------	--

PREPARATION:

- (a) Connect television camera ECU connector.
- (b) Disconnect Audio head unit "R38" connector.
- (c) Using SST (Navigation Check Wire P/N 09843-18050), connect the terminal TX+ to terminal TX- of "R38" connector of radio receiver assembly.

CHECK:

Operate the panel switch and the touch switch of the display and check that the navigation functions. (Check that AVC-LAN is recovered.)

OK	Replace the radio receiver assembly.
-----------	---

NG

Replace the navigation ECU.

REAR VIEW MONITOR SYSTEM

DICDM-01

DESCRIPTION

1. GENERAL

- (a) To assist the driver in parking the vehicle by monitoring the rear view, this system has a television camera mounted on the luggage compartment door to display the rear view of the vehicle on the multi-display.
- (b) This system consists of the following components: television camera ECU, television camera assy, multi-display.
- (c) This system is equipped with a self-diagnosis system, which is operated on a dedicated window that appears on the display panel, just as in the navigation system.

2. FUNCTION OF COMPONENTS

- (a) The television camera ECU controls the system by using information from the following components.

Item	Function
Television Camera Assy	Mounted on the luggage door to transmit the rear view of the vehicle to the television camera ECU.
Television Camera ECU	Transmits video signals, which contain a composite of the rear view of the vehicle taken with the television camera and the warning message, to the multi-display.
Multi-display	Receives video signals containing a composite of the rear view of the vehicle and the warning message from the television camera ECU, and displays them on the display panel.
Neutral Start Switch	Transmits a reverse shift position signal to the television camera ECU through communication. This signal switches the display of the multi-display to operate this system.

3. COMMUNICATION SYSTEM

- (a) This rear view monitor system communicates between the components by AVC-LAN.

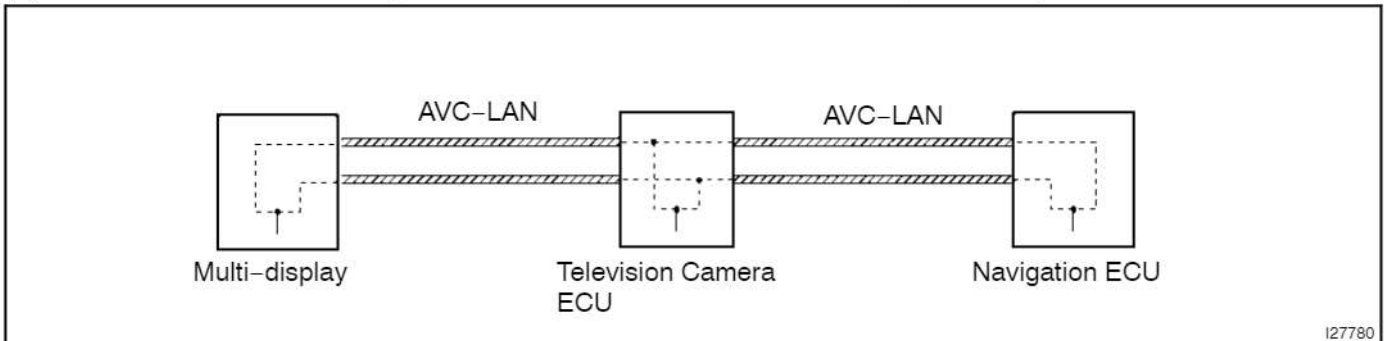

4. DIAGNOSTIC FUNCTION

- (a) This rear view monitor system has diagnostic function (Displayed on "NAVIGATION SYSTEM" of the multi-display assembly).
- (b) Three-digit number (in hexadecimal notation) of "unit code (physical address)" is set in each component composing AVC-LAN.
- (c) Two-digit number (in hexadecimal notation) of "logical address" is set in each function consists of internal AVC-LAN.

5. OUTLINE OF AVC-LAN

(a) What is AVC-LAN?

AVC-LAN is the abbreviation for Audio Visual Communication-Local Area Network. This is a unified standard co-developed by 6 audio manufacturers associated with Toyota Motor Corporation.

The unified standard includes signals, such as audio, visual and signals for switch indication and communication.

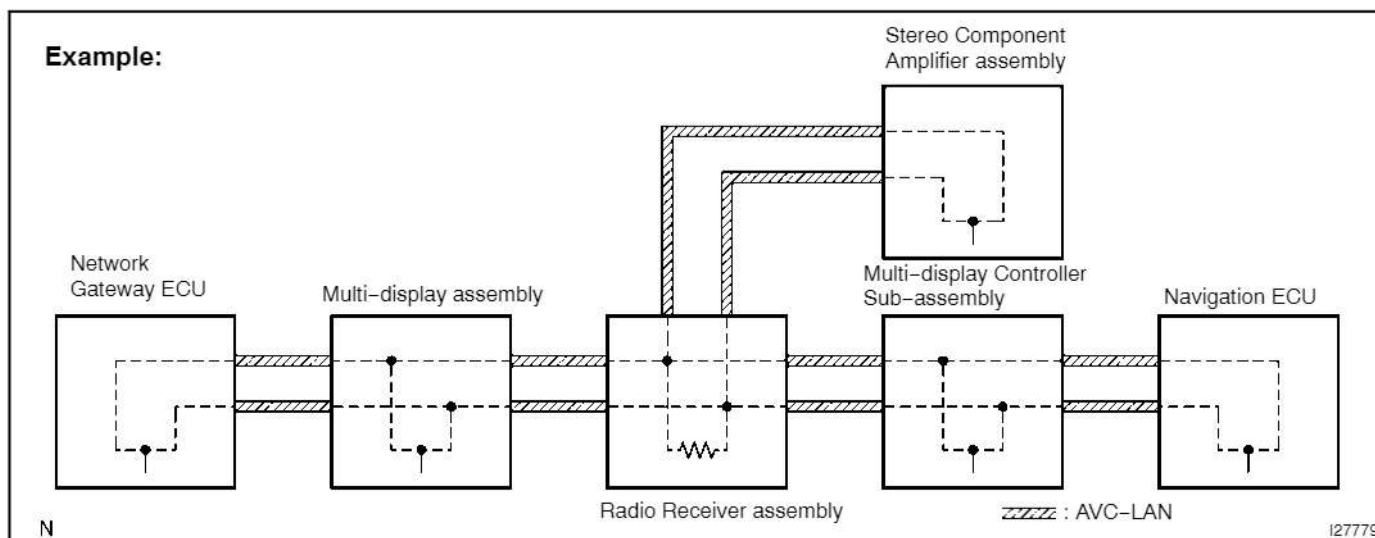

(b) Objectives

Recently developments in car audio systems have been rapid and functions have been changed drastically. The conventional system has been switched to the multi-media type such as a navigation system. At the same time customers want to upgrade their audio systems. This is the factor that lies behind this standardization.

The concrete objectives are explained below.

- (1) When products by different manufacturer were combined together, malfunctions such as sound failure occurred. This problem can be solved by standardization of signals.
- (2) Various types of after market products are available.
- (3) Because of the above (2), each manufacturer has been able to concentrate on developing products in their strongest field. This has enabled the development of inexpensive products.
- (4) In general, a new product developed by one particular manufacturer could not be used due to a lack of compatibility with other manufacturers products. By developing this new standard, users can enjoy a range of compatible products from different manufacturers anytime they want.

(c) The above stated are the reasons for the introduction of AVC-LAN. Under this standardization, development of new products no longer causes systematic errors.

HINT:

- When +B short or GND short is detected in AVC-LAN circuit, communication stops, and the audio system does not function normally.
- When audio system is not equipped with a navigation system, the audio head unit is the master unit. When the audio system is equipped with a navigation system, the multi-display is the master unit.
- The radio receiver is equipped with a resistor (60 to 80 Ω) for communication.
- The car audio system using AVC-LAN circuit has a diagnosis function.
- Each product has its own specified number called a physical address (three-digit number). Numbers are also allotted to each function within a product, which are called logical addresses (two-digit number).

6. NOTES FOR REAR VIEW MONITOR

- (a) Notes for rear view monitor.
- (1) The rear view monitor may not function properly if subjected to a severe blow by any hard object.
 - (2) Do not "scrub" the cover part of the camera (resin made). Scrubbing it may scratch the cover and affect the image. Prevent organic solvents, waxes, bond removing solvents, or glass coating from adhering to the cover. Clean off immediately, and wash with water.
 - (3) Exposing the camera to sudden temperature change may affect proper function.
 - (4) A clear image may not appear if the camera is dirty with snow, mud, etc. In that case, wash with water and wipe off. Use a detergent if necessary to remove dirt.
- (b) Images are difficult to discern even in normal conditions if:
- (1) Camera screen is frosted over (the image immediately after turning the ignition switch ON may be blurred or darker than normal).
 - (2) A strong beam of light, such as a sunbeam or headlight, hits the camera.
 - (3) It is too dark around the camera (at night etc.).
 - (4) The ambient temperature around the camera is either too high or too low.

HINT:

When a strong light, such as a sunbeam reflected off the vehicle's body, hits the camera, the image may be blurred. It is called the "SMEAR" phenomenon, peculiar to the CCD camera.

HOW TO PROCEED WITH TROUBLESHOOTING

HINT:

Troubleshoot in accordance with the procedure on this pages.

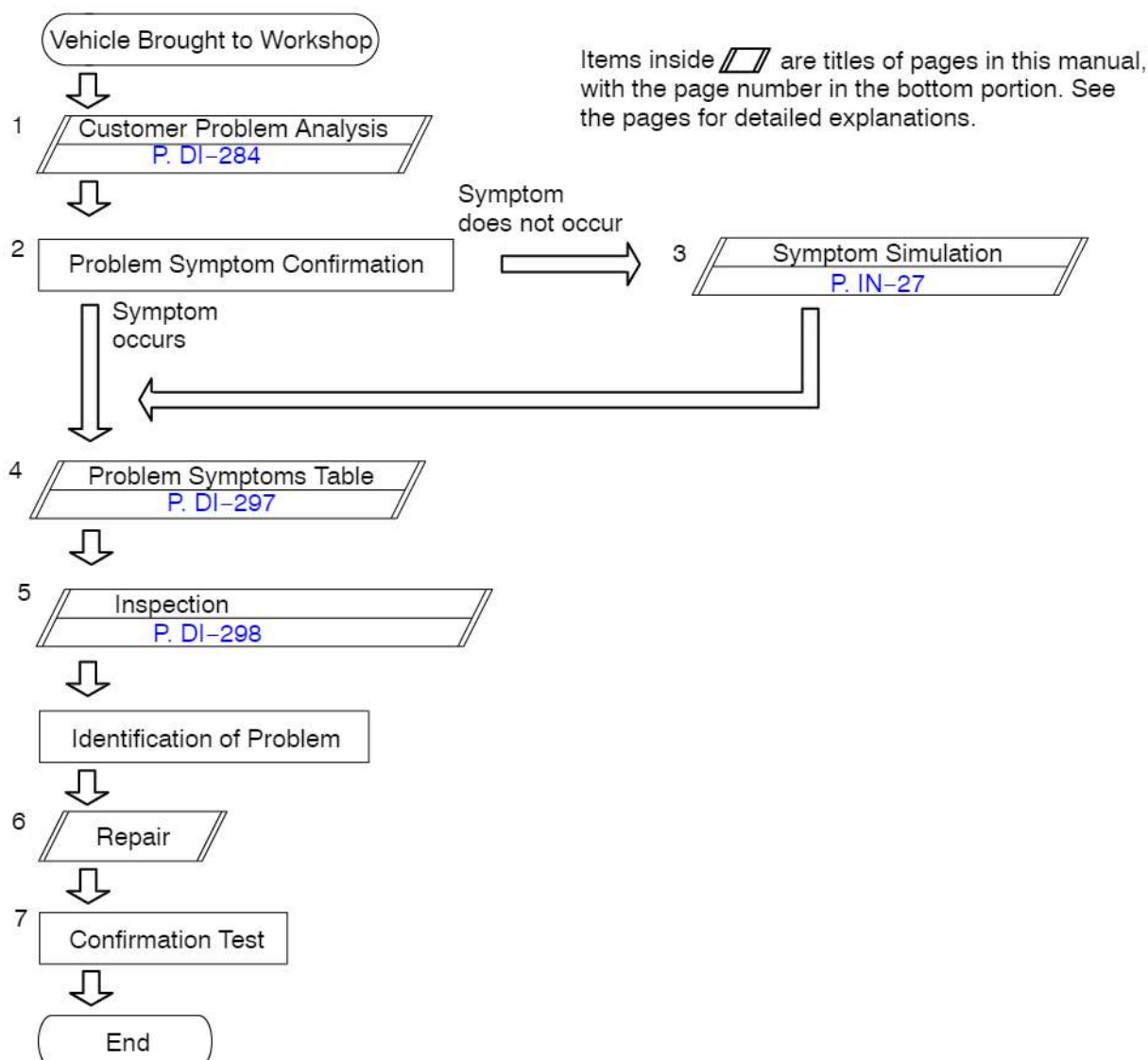

Before troubleshooting:

- (a) Using the tester, check the battery voltage.

Standard Voltage: 11 to 14 V

- (b) Perform a visual check for blown fuses, and poor connections in connectors.

CUSTOMER PROBLEM ANALYSIS CHECK

REAR VIEW MONITOR SYSTEM

Inspector's name: _____

Customer's Name		VIN	
		Production Date	
		Licence Plate No.	
Brought-in Date	/ /	Odometer Reading	km Mile

Date of First Occurrence	/ /
Frequency of Problem Occurrence	<input type="checkbox"/> Constant <input type="checkbox"/> Intermittent (Times a day)

Problem Symptom	Condition on the normal return	<input type="checkbox"/> ACC ON <input type="checkbox"/> E/G starts running <input type="checkbox"/> SW operating
	Condition on the trouble	<input type="checkbox"/> ACC OFF → ON <input type="checkbox"/> () SW operating <input type="checkbox"/> others

DTC Check	Parts name	DTC (1st time)	DTC (2nd time)
	Television camera ECU		

PRE-CHECK

1. DIAGNOSTIC START-UP/FINISH

HINT:

- The illustrations may differ depending on the device settings (option, etc.). Therefore, some detailed areas may not be shown exactly same as on the actual vehicle.
 - After the ignition switch is turned on, check that the map is displayed before starting the diagnostic mode. Otherwise, some items cannot be checked.
- (a) There are 2 methods to start diagnostic mode. Start the mode by using one of them.

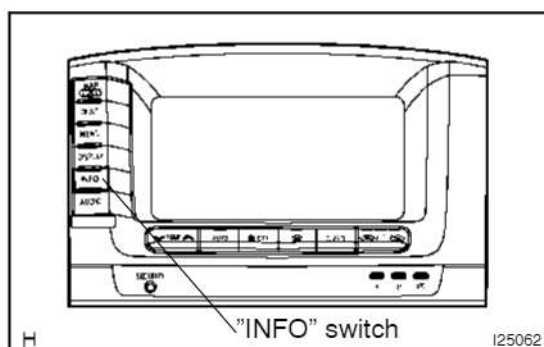

(b) Method 1

- (1) Start the engine.
- (2) While pressing and holding "INFO" switch, operate "TAIL" switch, OFF → TAIL → OFF → TAIL → OFF → TAIL → OFF.
- (3) The diagnostic mode starts and "Service Check" screen will be displayed. Service inspection starts automatically and the result will be displayed.

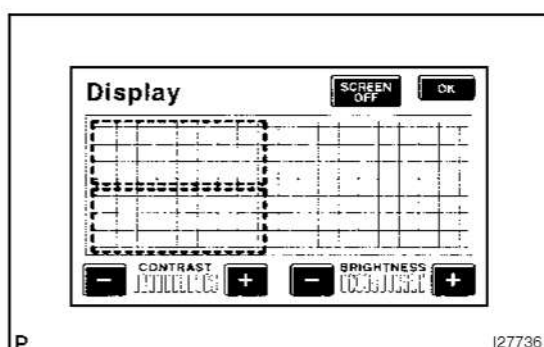

(c) Method 2

- (1) Start the engine.
- (2) Switch to the "Display Check" screen.
- (3) From the display adjustment screen, touch the corners of the screen in the following order: upper left → lower left → upper left → lower left → upper left → lower left.
- (4) The diagnostic mode starts and "Service Check" screen will be displayed. Service inspection starts automatically and the result will be displayed.

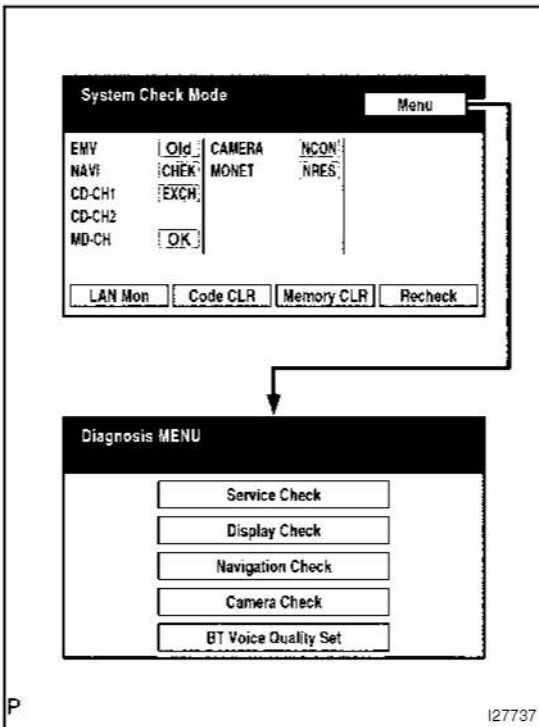

- (d) **Diagnosis MENU**
Pressing the menu switch on the service check screen, diagnostic window will be displayed.
- (e) There are 2 methods to exit. Use one of them.
(1) Turn the ignition switch off.
(2) Press the "Display" switch for 3 seconds.

2. SERVICE CHECK MODE (DTC CHECK)

HINT:

The illustrations may differ depending on the device settings (option, etc.). Therefore, some detailed areas, may not be shown exactly same as on the actual vehicle.

- (a) Start the diagnostic mode.

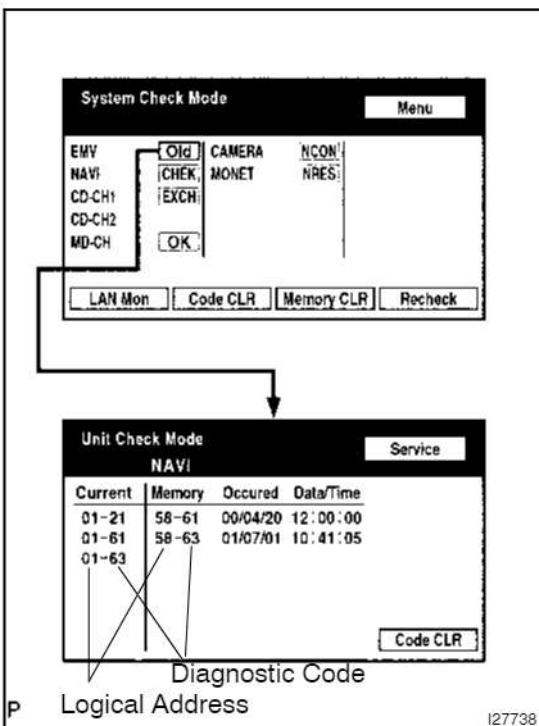

- (b) Read the service check result.
If all devices report is "EXCH", "CHEK" or "Old" touch the display to check the contents on the "Unit Check Mode" screen and fill them on the customer problem analysis check sheet.

HINT:

- If all check resultS are "OK" go to communication DTC check (Go to step 3).
- If a device name is not known, its physical address is displayed.

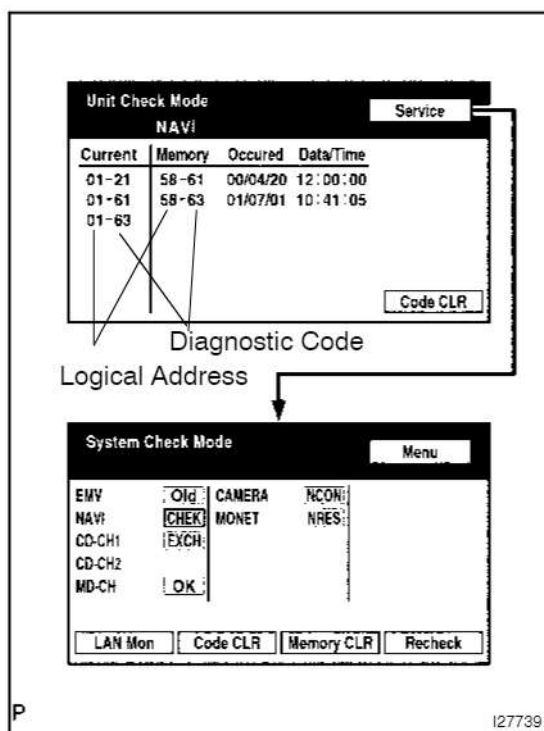

HINT:

If "EXCH", "CHEK" and "Old" as well as "OK" exist, press the service switch to return to the "System Check Mode". Then, check the "Unit Check Mode" screen and fill them in on the customer problem analysis check sheet.

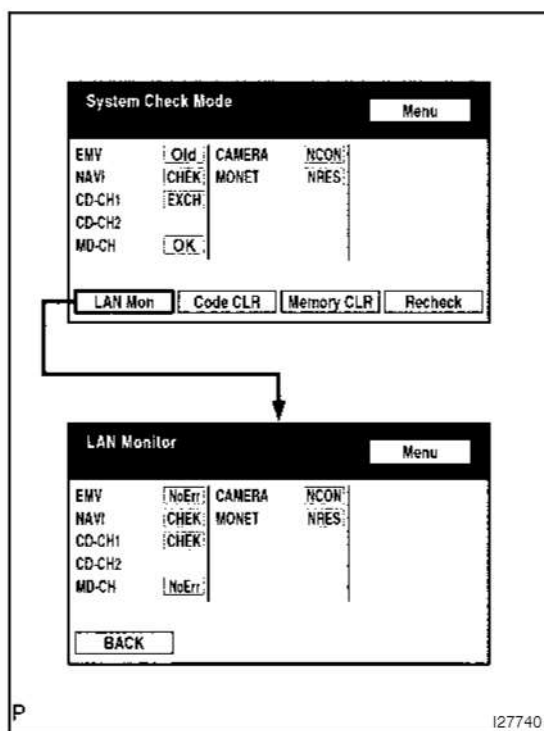

(c) Read the communication diagnostic check result.

- (1) Return to the "System Check Mode", and press "LAN Mon" switch to enter the LAN monitor window.

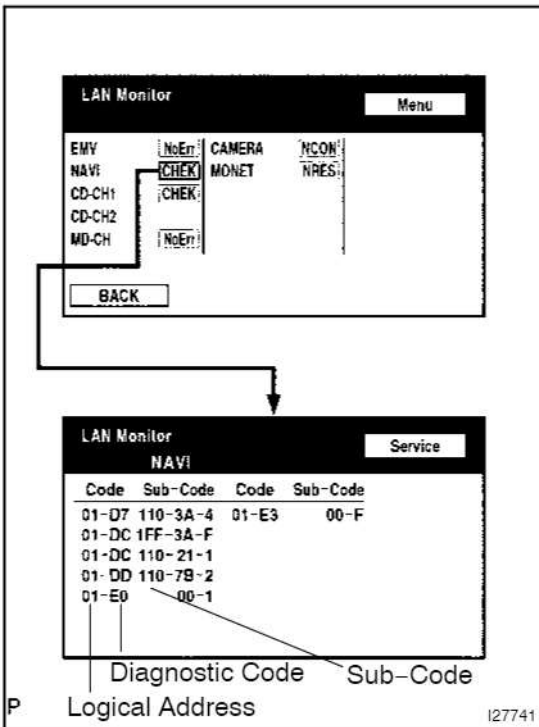

- (2) If the result is "CHEK" or "Old" touch this display to check the contents on the "Unit Check Mode" screen and fill them in on the customer problem analysis check sheet.

HINT:

- If all check results are "No Err" the system judges that no DTC exists.
- The sub-code (relevant device) will be indicated by its physical address.

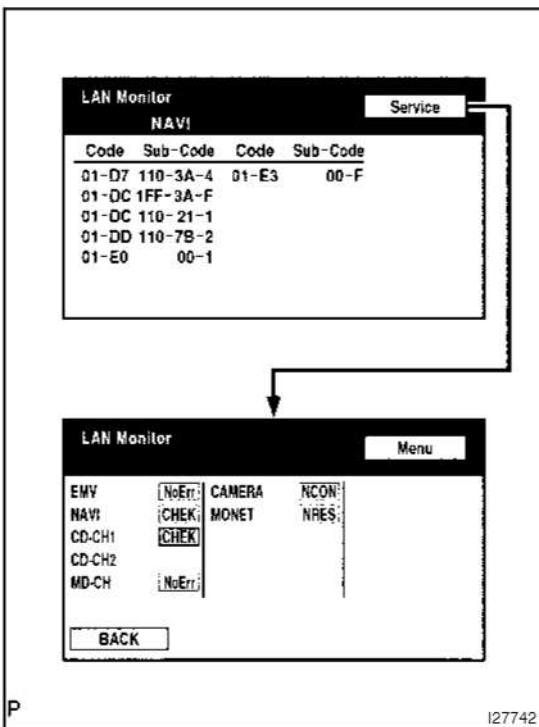

HINT:

If other devices return "CHEK" press the "Service" switch to return to the "LAN Monitor" screen. Then, check the individual communication diagnostic screen for the next device and fill out the result on the customer problem analysis check sheet.

3. SERVICE CHECK MODE (DTC CLEAR/RECHECK)

HINT:

The illustrations may differ from the actual vehicle depending on the device settings and options.

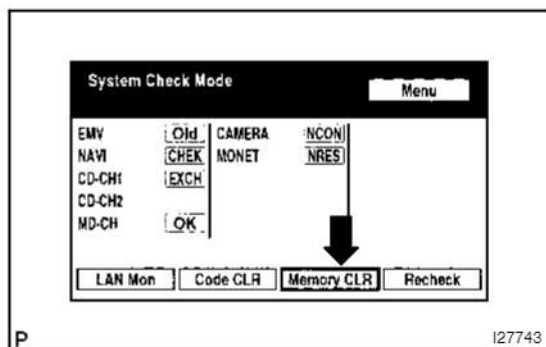

- (a) Clear DTC
 (1) Press "Memory CLR" switch for 3 seconds.

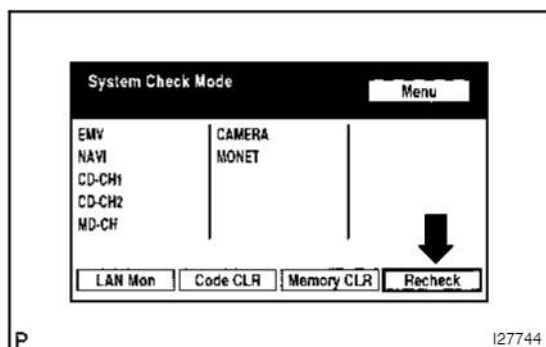

- (2) Check result is cleared.
 (b) Recheck
 (1) Press the "Recheck" switch.

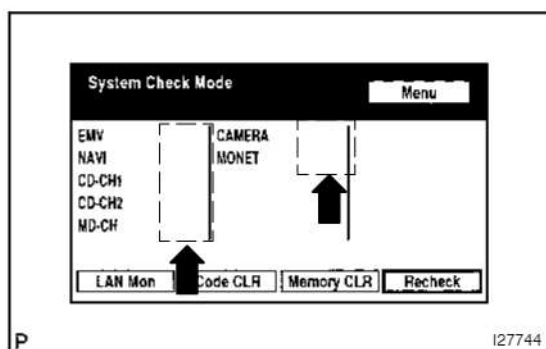

- (2) Confirm that all diagnostic codes are "OK" when the check results are displayed.
 If a code other than "OK" is displayed, troubleshoot again.

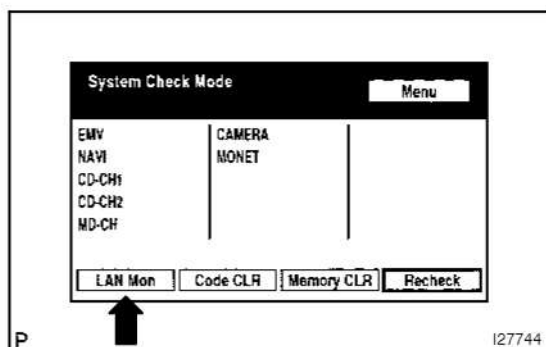

- (3) Press "LAN Mon" to switch to "LAN Monitor" mode.

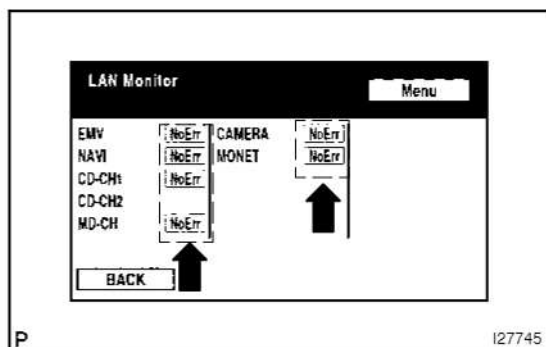

- (4) Confirm that all diagnostic codes are "No Err".
 If a code other than "No Err" is displayed, troubleshoot again.

4. FAIL-SAFE CHART

If the television camera ECU detects a malfunction, the fail-safe functions shown in the table below are activated.

Malfunction parts	Detecting condition	Function "Manual Assist Mode"	Function "Serial Parking Assist Mode"
Television camera assy	<ul style="list-style-type: none"> • Transmission of television camera malfunction signal 	Stops signal reception and displays a dark screen	Stops signal reception and displays a dark screen
Television camera ECU	<ul style="list-style-type: none"> • Malfunction of television camera ECU unit 	Stops system operation	Stops system operation

DIAGNOSTIC TROUBLE CODE CHART

HINT:

DTC is displayed on the multi-display (See page DI-285).

1. TELEVISION CAMERA ECU (Physical address: 1AC)

HINT:

- *1: Even if no failure is detected, this code may be stored depending on the battery condition or voltage for starting the engine.
- *2: This code may be stored when the ignition switch is turned to the START position again in 1 minute after the engine starts.
- *3: This code may be stored when the ignition switch is turned to the START position again after the engine starts.
- *4: When 210 seconds have elapsed after pulling out the power supply connector of the master component with the ignition switch in the ACC or ON position, this code is stored.

(a) Logical address: 01 (Communication control)

DTC	Diagnosis item	Condition	Countermeasure and inspected parts
D6 *1	Absence of Master	Component in which this code is recorded was disconnected from system with ignition switch is in ACC or ON. Or, when this code was recorded, multi-display assy was disconnected.	<ul style="list-style-type: none"> • Check harness for power supply of multi-display assy (See page DI-259). • Check harness for communication system of multi-display assy (See page DI-307). • Check harness for power supply of television camera ECU (See page DI-298). • Check harness for communication system of television camera ECU (See page DI-301).
D7 *4	Communication Check Error	Component in which this code is recorded is or was disconnected from system after engine start. Or, when recording this code, multi-display assy was disconnected.	<ul style="list-style-type: none"> • Check harness for power supply of multi-display assy (See page DI-259). • Check harness for communication system of multi-display assy (See page DI-307). • Check harness for power supply of television camera ECU (See page DI-298). • Check harness for communication system of television camera ECU (See page DI-301).
DC *2	Transmission Error	Transmission to component shown by sub-code failed. (Detecting this DTC does not always mean actual failure.)	If same sub-code is recorded in other components, check harness for power supply and communication system of all components shown by code.
DD *3	Master Reset (Momentary Interruption)	After engine start, multi-display assy was disconnected from system.	<ul style="list-style-type: none"> • Check harness for power supply of multi-display assy (See page DI-259). • Check harness for communication system of multi-display assy (See page DI-307). • If this error occurs frequently, replace multi-display assy.
DF *4	Master Error	Due to defective condition of component with a display, master function is switched to audio equipment. Error occurs in communication between sub-master (audio) and master component.	<ul style="list-style-type: none"> • Check harness for power supply of multi-display assy (See page DI-259). • Check harness for communication system of multi-display (See page DI-307). • Check harness for communication system between multi-display assy and radio receiver assy (See page DI-275).
E0 *1	Registration Completion Instruction Error	"Registration Completion Instruction" command from master cannot be received.	Since this DTC is provided for engineering purpose, it may be detected when no actual failure exists.

E2	ON/OFF Instruction Parameter Error	Error occurs in ON/OFF controlling command from multi-display assy.	Replace multi-display assy.
E3 *1	Registration Request Transmission	<ul style="list-style-type: none"> •Registration Request command is output from slave component. •Registration Connection Check Instruction, Registration Request command is output from sub-master component. 	Since this DTC is provided for engineering purpose, it may be detected when no actual failure exists.

(b) Logical address: 5C (Camera unit)

DTC	Diagnosis item	Condition	Countermeasure and inspected parts
40	Camera Picture Error	Synchronous signal from the camera cannot be transmitted.	Check the wire harness between television camera assy and television camera ECU (See page DI-307).

PARTS LOCATION

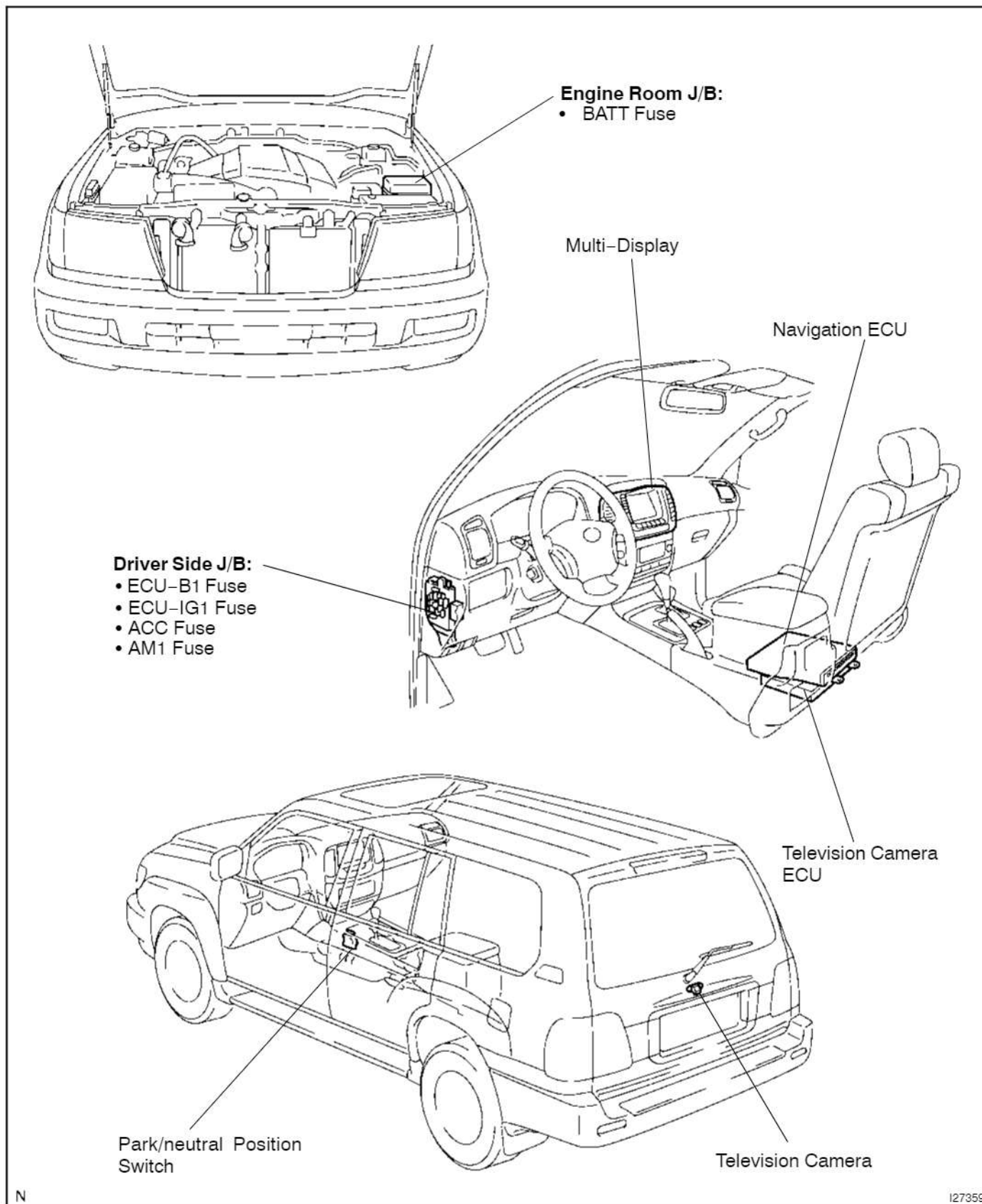

TERMINALS OF ECU

1. TELEVISION CAMERA ASSY

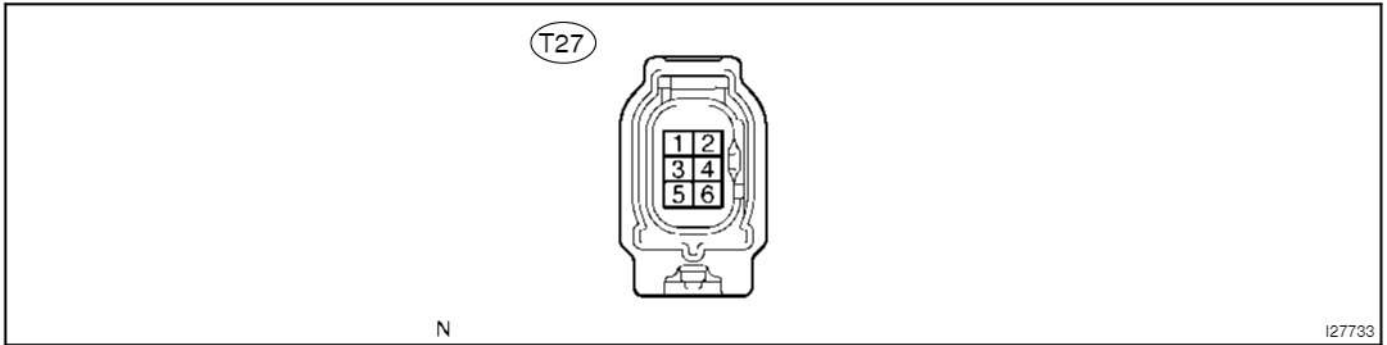

Symbols (Terminal No.)	Wiring Color	Terminal Description	Condition	Specified value
CV- (T27-1) - CGND (T27-3)	BR - W	Display signal (-)	Always	Below 1 Ω
CV+ (T27-2) - CGND (T27-3)	R - W	Display signal (+)	IG switch ON, shift lever R position	Signal waveform 1
CGND (T27-3) - Body ground	W - Body ground	Power ground	Always	Below 1 Ω
CB+ (T27-4) - CGND (T27-3)	B - W	Power source	IG switch ON, shift lever R position	6 V

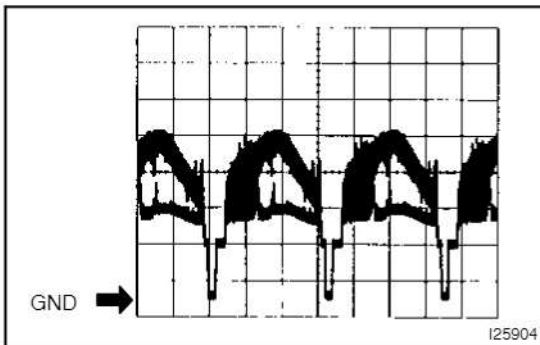

- (a) Reference:
Oscilloscope waveform
(1) Waveform 1

Item	Content
Measure terminal	CV+ - CV-
Measure set	0.2 V/DIV, 0.2 μ S/DIV
Condition	Ignition switch: ON, Shift lever: R position

2. TELEVISION CAMERA ECU

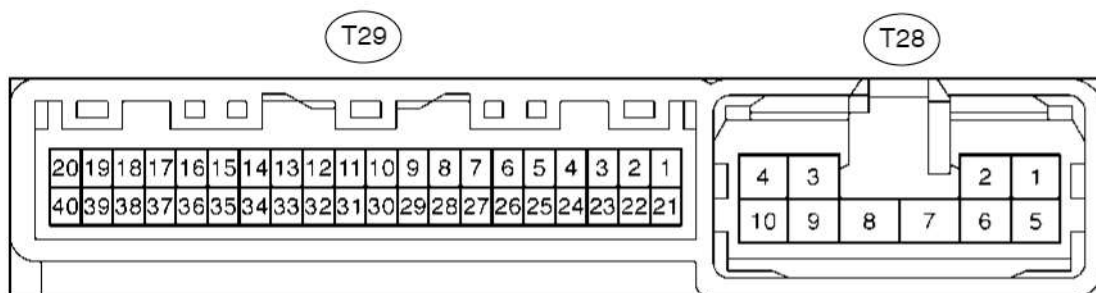

N

I27782

Symbols (Terminal No.)	Wiring Color	Terminal Description	Condition	Specified value
+B (T29-1) - GND1 (T29-8)	L-Y - W-B	Battery Supply	Always	10 to 14 V
IG (T29-2) - GND1 (T29-8)	B-W - W-B	IG signal input	IG switch ON	10 to 14 V
ACC (T29-5) - GND1 (T29-8)	GR - W-B	ACC signal input	IG switch ON or ACC	10 to 14 V
GND1 (T29-8) - Body ground	W-B - Body ground	Power ground	Always	Below 1 Ω
VG (T28-9) - GND1 (T29-8)	Shielded - W-B	Display signal output ground (Shielded)	Always	Below 1 Ω
R (T28-10) - GND1 (T29-8)	Y - W-B	Display signal output (Red)	While displaying map or back monitor	Signal waveform 2
G (T28-11) - GND1 (T29-8)	W - W-B	Display signal output (Green)	While displaying map or back monitor	Signal waveform 2
B (T28-12) - GND1 (T29-8)	R - W-B	Display signal output (Blue)	While displaying map or back monitor	Signal waveform 2
B1 (T28-13) - GND1 (T29-8)	R - W-B	Display signal input (Blue)	While displaying map	Signal waveform 2
G1 (T28-14) - GND1 (T29-8)	W - W-B	Display signal input (Green)	While displaying map	Signal waveform 2
R1 (T28-15) - GND1 (T29-8)	Y - W-B	Display signal input (Red)	While displaying map	Signal waveform 2
VG1(T28-16) - GND1 (T29-8)	Shielded - W-B	Display signal input ground (Shielded)	Always	Below 1 Ω
CGND (T28-19) - GND1 (T29-8)	W - W-B	Television camera ground	Always	Below 1 Ω
CB+ (T28-20) - GND1 (T29-8)	B - W-B	Power source to television camera	IG switch ON, shift lever R position	6 V
REV (T28-27) - GND1 (T29-8)	R-B - W-B	Reverse signal input	IG switch ON, shift lever R position	10 to 14 V
TX+ (T28-29)	P	AVC-LAN control bus	See "Service check mode"	-
TX- (T28-30)	L-B	AVC-LAN control bus	See "Service check mode"	-
SYNC (T28-31) - GND1 (T29-8)	G - W-B	Synchronized signal output	While displaying map or back monitor	Signal waveform 3
VR (T28-32) - GND1 (T29-8)	B - W-B	Display signal output ground	Always	Below 1 Ω

VR1 (T28-33) – GND1 (T29-8)	B – W-B	Display signal input ground	Always	Below 1 Ω
SYN1 (T28-34) – GND1 (T29-8)	G – W-B	Synchronized signal input	While displaying map	Signal waveform 3
TX1- (T28-35)	L-B	AVC-LAN control bus	See "Service check mode"	-
TX1+ (T28-36)	P	AVC-LAN control bus	See "Service check mode"	-
CV- (T28-39) – GND1 (T29-8)	Shielded – W-B	Television camera ground (Shielded)	Always	Below 1 Ω
CV+ (T28-40) – GND1 (T29-8)	R – W-B	Display signal of television camera input	IG switch ON, shift lever R position	Signal waveform 1

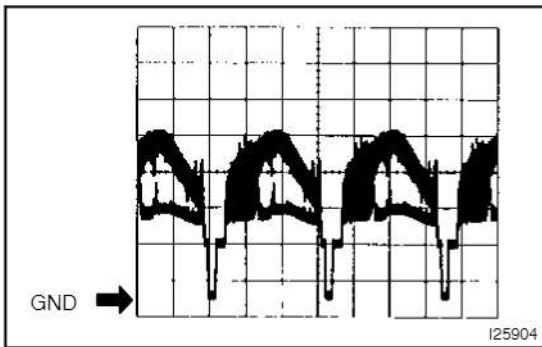

(a) Reference:
Oscilloscope waveform
(1) Waveform 1

Item	Content
Measure terminal	CV+ – GND1
Measure set	0.2 V/DIV, 0.2 μS/DIV
Condition	Ignition switch: ON, Shift lever: R position

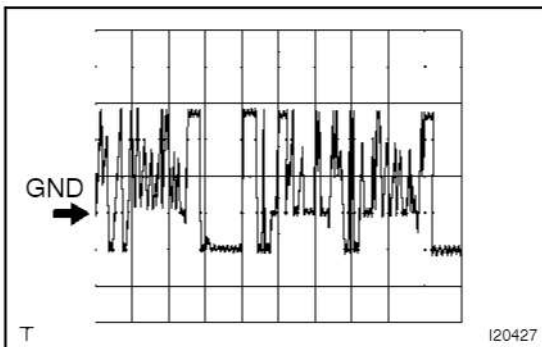

(2) Waveform 2

Item	Content
Terminal	R, G, B, R1, G1, B1, – GND1
Measure set	200 mV/DIV, 10 μS/DIV
Condition	Image is being displayed (Back guide monitor system or navigation system).

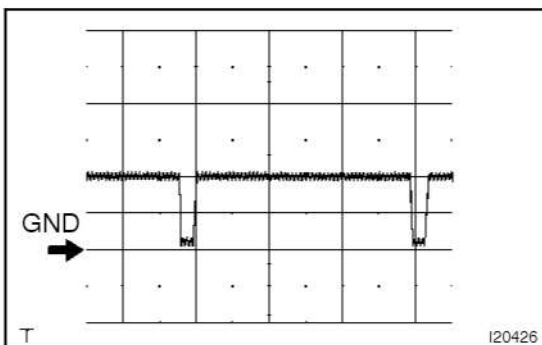

(3) Waveform 3

Item	Content
Terminal	SYNC, SYN1 – GND1
Measure set	500 mV/DIV, 10 μS/DIV
Condition	Image is being displayed (Back guide monitor system or navigation system).

PROBLEM SYMPTOMS TABLE

Symptom	Suspected Area	See page
When shift lever is in R position, rear view monitor picture is not displayed (Screen is not black).	<ol style="list-style-type: none"> 1. Power source circuit 2. Reverse signal circuit 3. AVC-LAN circuit 4. Television camera ECU 	DI-298 DI-304 DI-301 -
When shift lever is in R position, rear view monitor picture is not displayed (Screen is black).	<ol style="list-style-type: none"> 1. Display signal circuit (Television camera assembly - Television Camera ECU) 2. Television camera assembly 3. Television camera ECU 	DI-307 - -
When shift lever is not in R position, rear view monitor picture is displayed.	<ol style="list-style-type: none"> 1. Reverse signal circuit 2. Television camera ECU 	DI-304 -
Rear view monitor image (color, disorder of picture) is something wrong.	<ol style="list-style-type: none"> 1. Display signal circuit (Television camera assembly - Television Camera ECU) 2. Display signal circuit (Television Camera ECU - Multi-display) 3. Television camera assembly 4. Television camera ECU 5. Multi-display 	DI-307 DI-307 - - -

CIRCUIT INSPECTION

Power Source Circuit

CIRCUIT DESCRIPTION

This circuit provides the power to the television camera ECU.

WIRING DIAGRAM

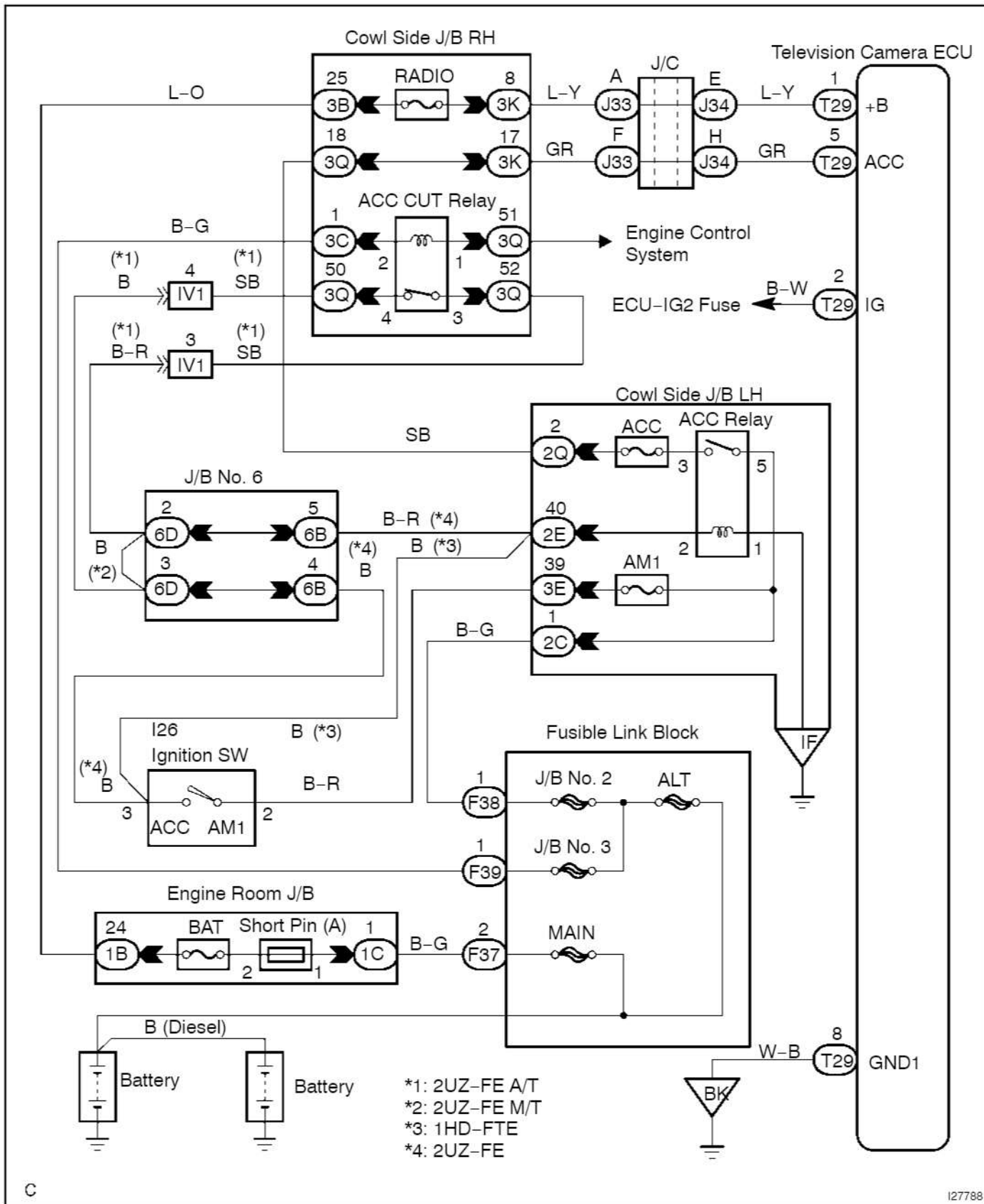

cardiagn.com

INSPECTION PROCEDURE

- 1 Check voltage between terminals +B, ACC, IG and GND1 of television camera ECU.**

Television Camera ECU:

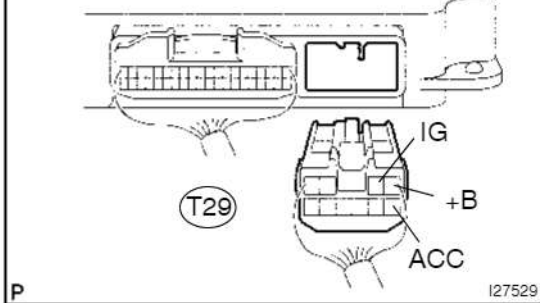

- (a) Disconnect the T29 connector from the television camera ECU.
 (b) Measure the voltage according to the value(s) in the table below.

Standard:

Tester connection	Condition	Specified condition
+B – Body ground	Always	10 to 14 V
ACC – Body ground	Ignition SW ACC	10 to 14 V
IG – Body ground	Ignition SW ON	10 to 14 V

NG**Repair or replace harness or connector.****OK**

- 2 Check continuity between terminal GND1 and body ground.**

Television Camera ECU:

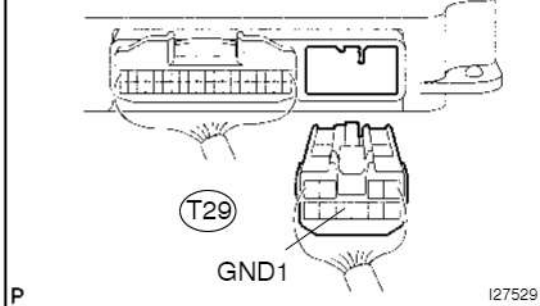

- (a) Disconnect the T29 connector from the television camera ECU.
 (b) Measure the resistance according to the value(s) in the table below.

Standard:

Tester connection	Condition	Specified condition
GND1 – Body ground	Always	Below 1 Ω

NG**Repair or replace harness or connector.****OK****Replace television camera ECU.**

AVC-LAN Circuit

CIRCUIT DESCRIPTION

Each unit of the "BACK MONITOR SYSTEM" connected with AVC-LAN (communication bus) transfers the signal of each switch by communication.

When short to +B or short to ground occurs in this AVC-LAN, the "BACK MONITOR SYSTEM" will not function normally as the communication is discontinued.

WIRING DIAGRAM

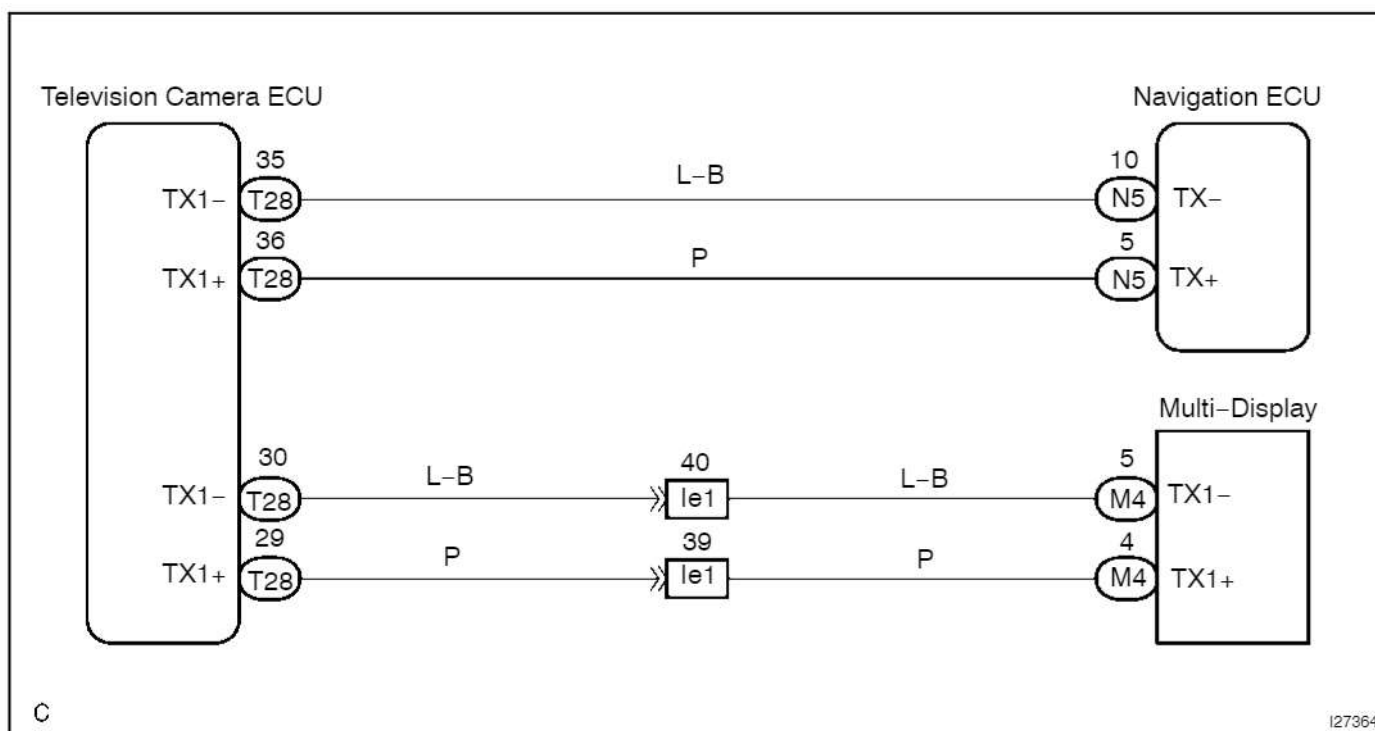

INSPECTION PROCEDURE

- 1 Check for open or short in harness and connector between navigation ECU and television camera ECU.

Television Camera ECU:

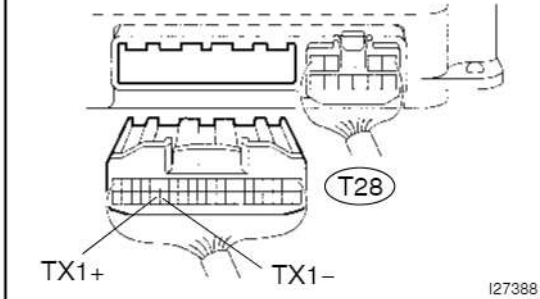

- (a) Disconnect the T28 connector from the television camera ECU.
 (b) Disconnect the N5 connector from the navigation ECU.
 (c) Measure the resistance according to the value(s) in the table below.

Standard:

Tester connection	Condition	Specified condition
TX1+ (T28-36) – TX+ (N5-5)	Always	Below 1 Ω
TX1- (T28-35) – TX- (N5-10)	Always	Below 1 Ω
TX1+ (T28-36) – Body ground	Always	10 k Ω or higher
TX1- (T28-35) – Body ground	Always	10 k Ω or higher

Navigation ECU:

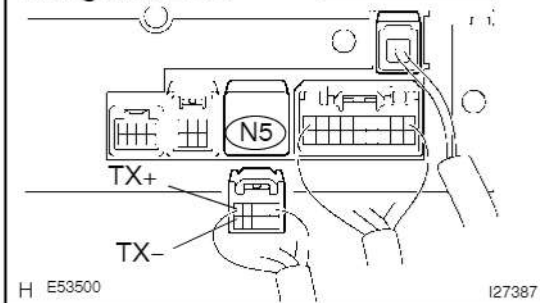

NG

Repair or replace harness or connector.

OK

2 Check for open or short in harness and connector between multi-display and television camera ECU.

Television Camera ECU:

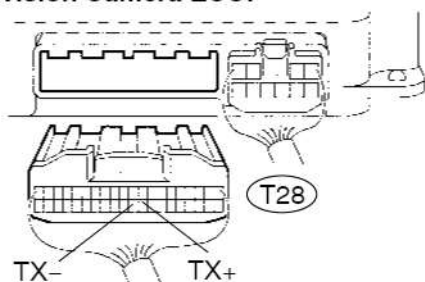

I27388

- Disconnect the T28 connector from the television camera ECU.
- Disconnect the M4 connector from the multi-display assembly.
- Measure the resistance according to the value(s) in the table below.

Standard:

Tester connection	Condition	Specified condition
TX+ (T28-29) - TX1+ (M4-4)	Always	Below 1 Ω
TX- (T28-30) - TX1- (M4-5)	Always	Below 1 Ω
TX+ (T28-29) - Body ground	Always	10 k Ω or higher
TX- (T28-30) - Body ground	Always	10 k Ω or higher

Multi-display assembly:

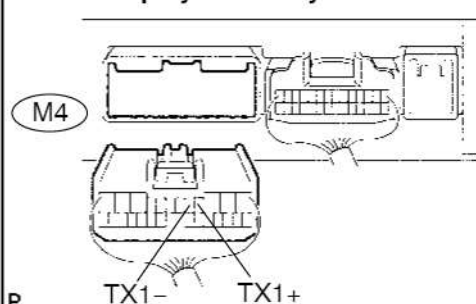

I27386

NG

Repair or replace harness or connector.

OK

Proceed to next circuit inspection shown in problem symptoms table (see page DI-297).

Reverse Signal Circuit

CIRCUIT DESCRIPTION

The television camera ECU receives the reverse signal from the park/neutral position switch.

WIRING DIAGRAM

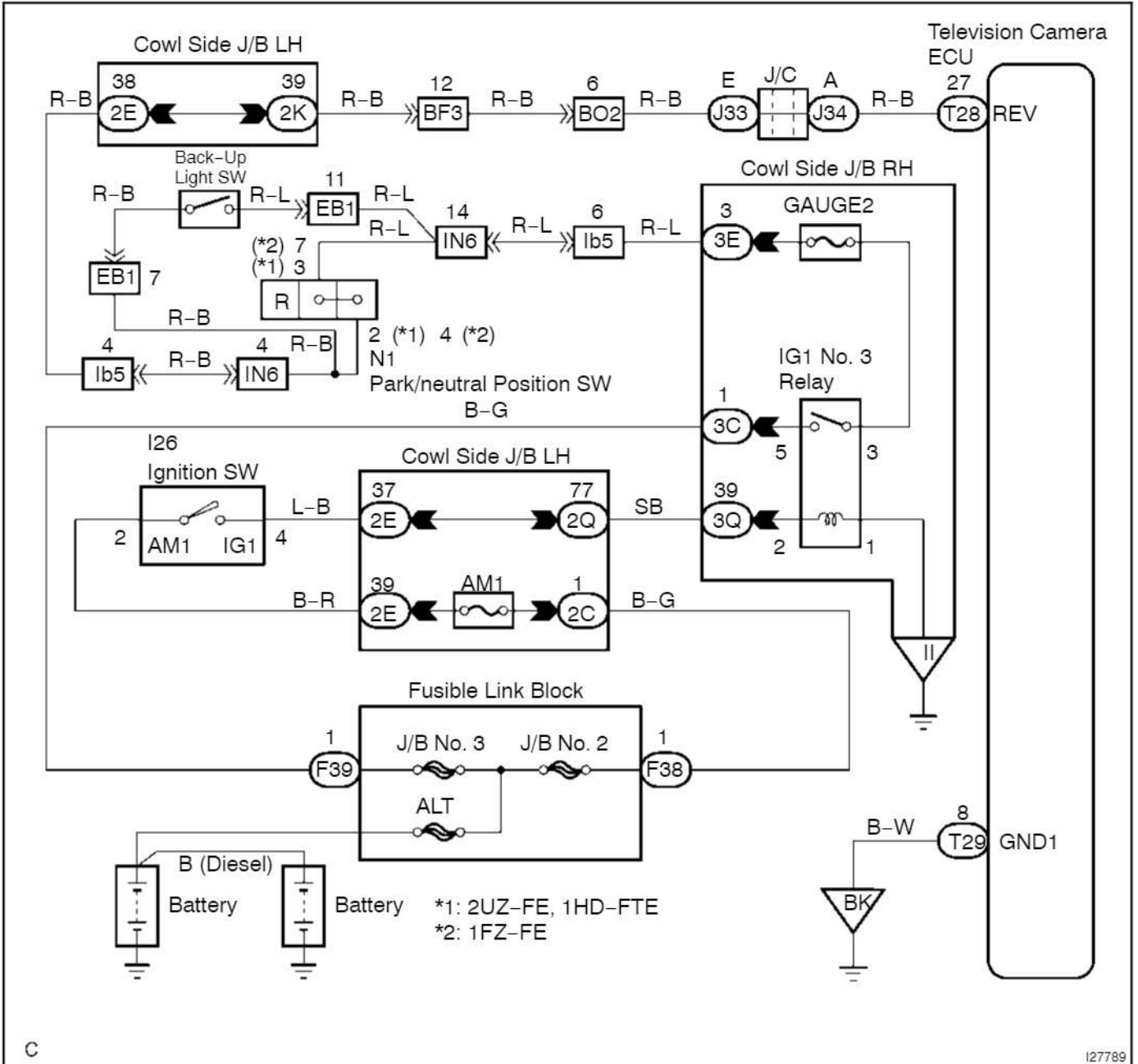

C

I27789

INSPECTION PROCEDURE

- 1 Check for open or short circuit in harness and connector between terminal REV of television camera ECU and park/neutral position switch.

Television Camera ECU:

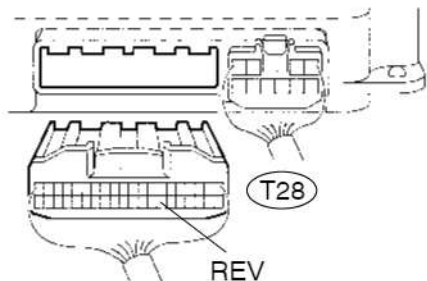

- Disconnect the T28 connector from the television camera ECU.
- Disconnect the P1 connector from the park/neutral position switch assembly.
- Measure the resistance according to the value(s) in the table below.

Standard:**A/T (2UZ-FE, 1HD-FTE):**

Tester connection	Condition	Specified condition
REV - N1-2	Always	Below 1 Ω
REV - Body ground	Always	10 k Ω or higher

A/T (1FZ-FE):

Tester connection	Condition	Specified condition
REV - N1-4	Always	Below 1 Ω
REV - Body ground	Always	10 k Ω or higher

M/T:

Tester connection	Condition	Specified condition
REV - B1-1	Always	Below 1 Ω
REV - Body ground	Always	10 k Ω or higher

NG**Repair or replace harness or connector.****OK**

- 2 Check for open circuit in harness and connector between terminal GND1 of television camera ECU and body ground.**

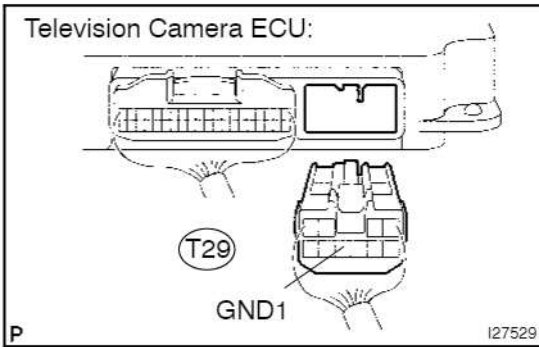

- (a) Connect the P1 connector to the park/neutral position switch assembly.
 (b) Measure the resistance according to the value(s) in the table below.

Standard:

Tester connection (Terminal No.)	Condition	Specified condition
GND1 (T29-8) – Body ground	Always	Below 1 Ω

NG**Repair or replace harness or connector.****OK**

- 3 Check voltage between terminals REV of television camera ECU and body ground.**

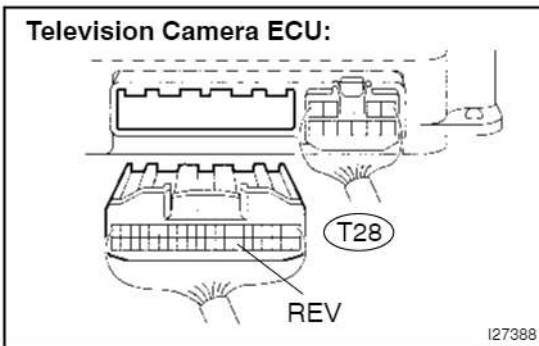

- (a) Measure the voltage according to the value(s) in the table below.

Standard:

Tester connection (Terminal No.)	Condition	Specified condition
REV (T28-27) –Body ground	IG SW ON, shift lever R position	10 to 14 V

NG**Inspect park/neutral position switch.****OK**

Proceed to next circuit inspection shown in problem symptoms table. (See page DI-209)

Display Signal Circuit

CIRCUIT DESCRIPTION

This is the display signal circuit from the multi-display controller sub-assembly to the multi-display assembly.

WIRING DIAGRAM

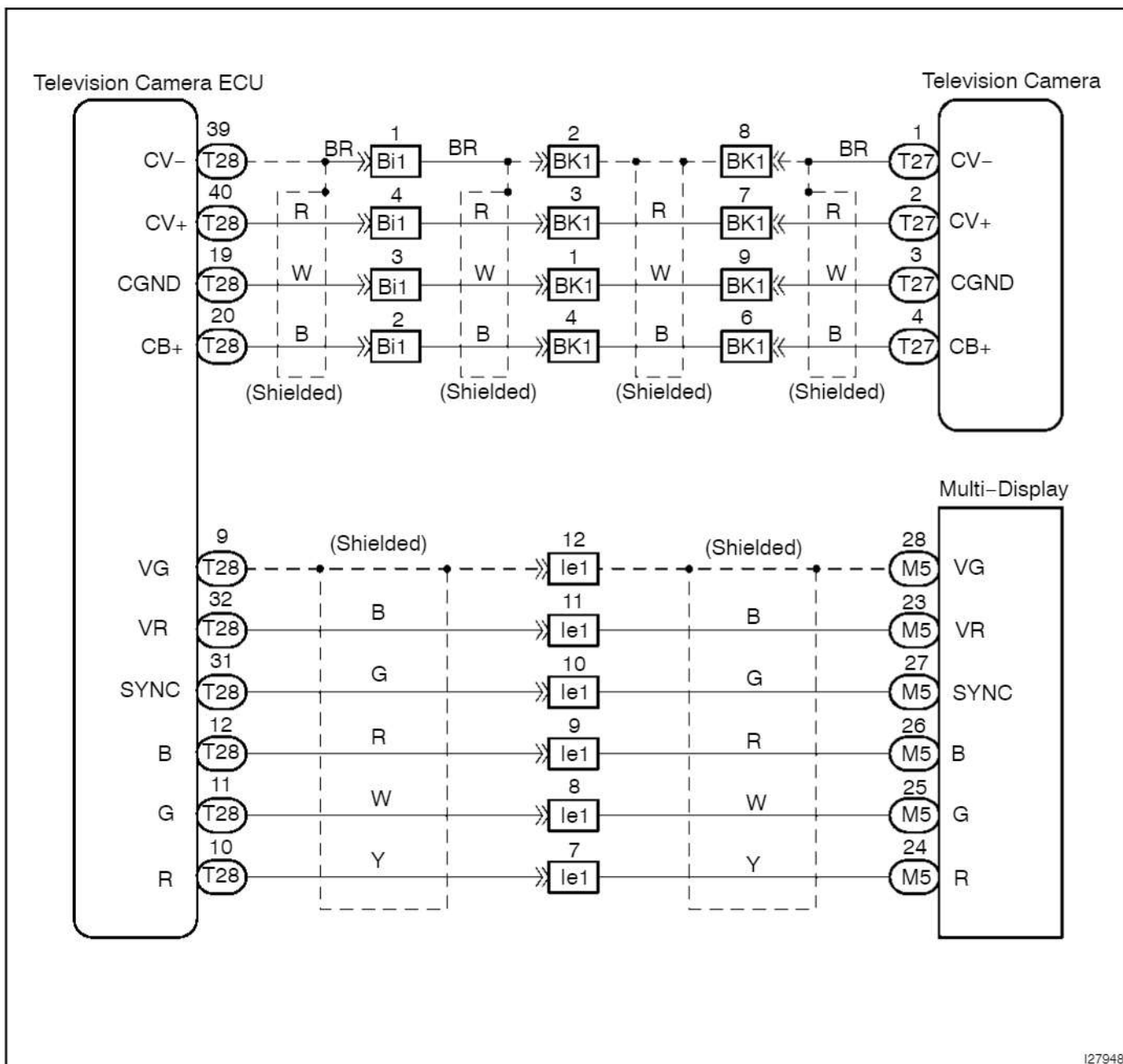

127948

INSPECTION PROCEDURE

- 1 Check for open or short circuit in harness and connector between television camera ECU and multi-display assembly.

Television Camera ECU:

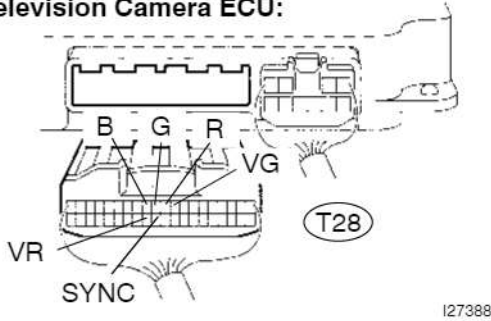

Multi-display:

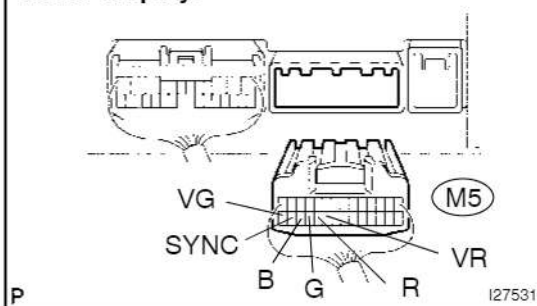

- (a) Disconnect the connector from the television camera ECU and multi-display assembly.
 (b) Measure the resistance according to the value(s) in the table below.

Standard:

Tester connection	Condition	Specified condition
R (T28-10) - R (M5-24)	Always	Below 1 Ω
G (T28-11) - G (M5-25)	Always	Below 1 Ω
B (T28-12) - B (M5-26)	Always	Below 1 Ω
SYNC (T28-31) - SYNC (M5-27)	Always	Below 1 Ω
VR (T28-32) - VR (M5-23)	Always	Below 1 Ω
VG (T28-9) - VG (M5-28)	Always	Below 1 Ω
R (T28-10) - Body ground	Always	10 k Ω or higher
G (T28-11) - Body ground	Always	10 k Ω or higher
B (T28-12) - Body ground	Always	10 k Ω or higher
SYNC (T28-31) - Body ground	Always	10 k Ω or higher
VR (T28-32) - Body ground	Always	10 k Ω or higher

NG**Repair or replace harness or connector.****OK**

2 Check for open or short circuit in harness and connector between television camera ECU and television camera.

Television Camera ECU:

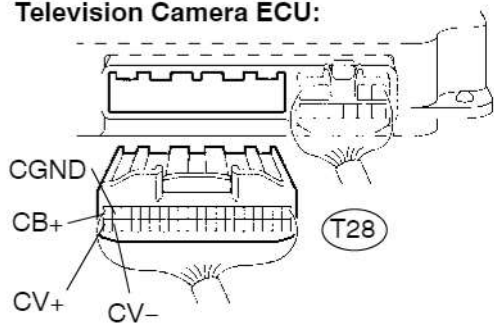

Television Camera assembly:

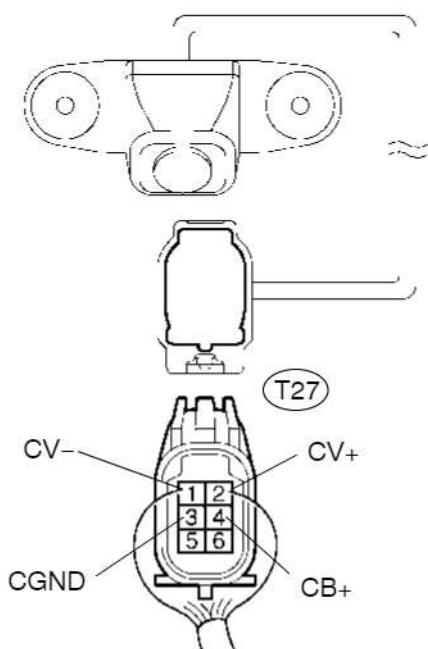

- Disconnect the T28 connector from the television camera ECU.
- Disconnect the T27 connector from the television camera assembly.
- Measure the resistance according to the value(s) in the table below.

Standard:

Tester connection (Terminal No.)	Condition	Specified condition
CB+ (T28-20) - CB+ (T27-4)	Always	Below 1 Ω
CGND (T28-19) - CGND (T27-3)	Always	Below 1 Ω
CV+ (T28-40) - CV+ (T27-2)	Always	Below 1 Ω
CV- (T28-39) - CV- (T27-1)	Always	Below 1 Ω
CB+ (T28-20) - Body ground	Always	10 k Ω or higher
CGND (T28-19) - Body ground	Always	10 k Ω or higher
CV+ (T28-40) - Body ground	Always	10 k Ω or higher
CV- (T28-39) - Body ground	Always	10 k Ω or higher

NG

Repair or replace harness or connector.

OK

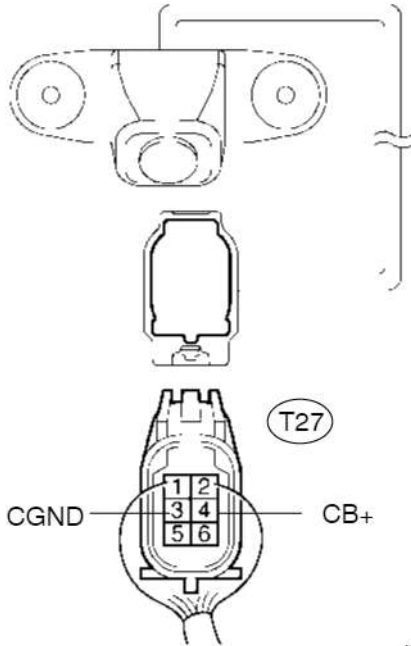
3 Check voltage between terminals +CB and CGND of television camera.
Television Camera assembly:

- (a) Connect the T28 connector to the television camera ECU.
 (b) Measure the voltage according to the value(s) in the table below.

Standard:

Tester connection (Terminal No.)	Condition	Specified condition
CB+ (T27-4) - CGND (T27-3)	IG SW ON, shift lever R position	Approx. 6 V

NG
Replace television camera ECU.
OK
Proceed to next circuit inspection shown in problem symptoms table. (See page DI-209)

VALVE BODY ASSEMBLY ON-VEHICLE REPAIR

AT11W-02

1. REMOVE ENGINE NO.2 UNDER COVER
2. DRAIN ATF

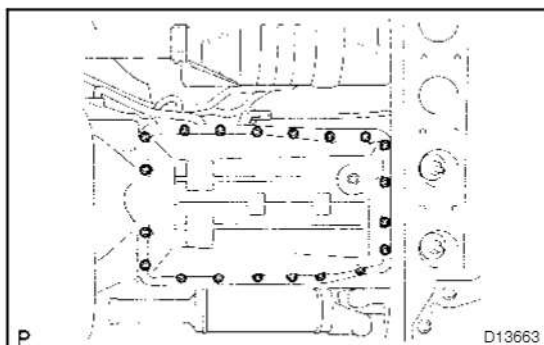

3. REMOVE OIL PAN

NOTICE:

Some fluid will remain in the oil pan.

- (a) Remove the 20 bolts.
- (b) Remove the oil pan gasket.

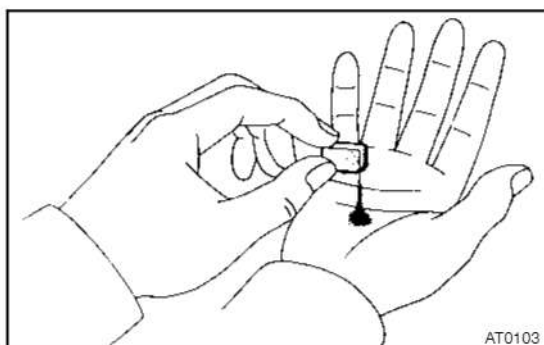

4. EXAMINE PARTICLES IN PAN

Remove the magnets and use them to collect steel particles. Carefully look at the foreign matter and particles in the pan and on the magnets to anticipate the type of wear you will find in the transmission.

Steel (magnetic)...bearing, gear and clutch plate wear
Brass (non-magnetic)...bushing wear

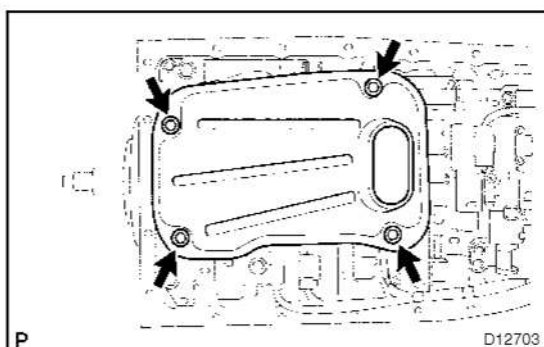

5. REMOVE OIL STRAINER

Remove the 4 bolts, the oil strainer and the O-ring.

NOTICE:

Be careful as some fluid will come out with the oil strainer.

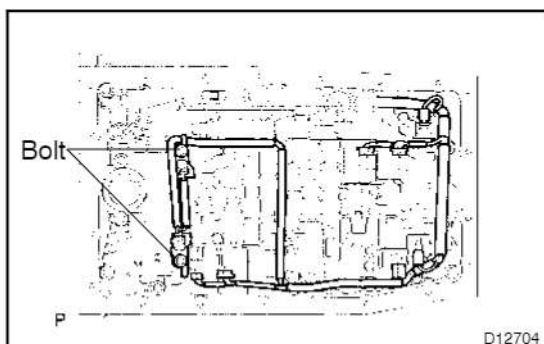

6. DISCONNECT TEMPERATURE SENSOR

- (a) Disconnect the 7 solenoid connectors.
- (b) Remove 2 bolts and the 2 temperature sensors clamp from the valve body.
- (c) Disconnect the 2 temperature sensor from the valve body.

7. DISCONNECT 7 CONNECTORS FROM SHIFT SOLENOID VALVES

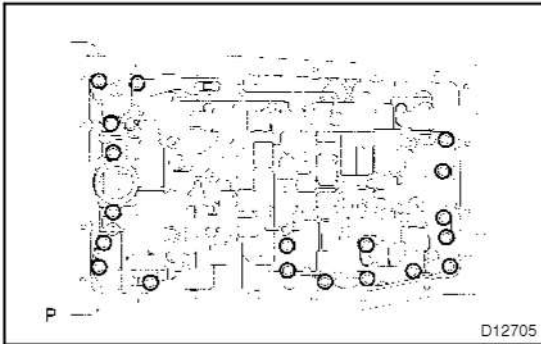

8. REMOVE VALVE BODY

- (a) Remove the 19 bolts and the valve body.
- (b) Remove the 3 drum seal gaskets.

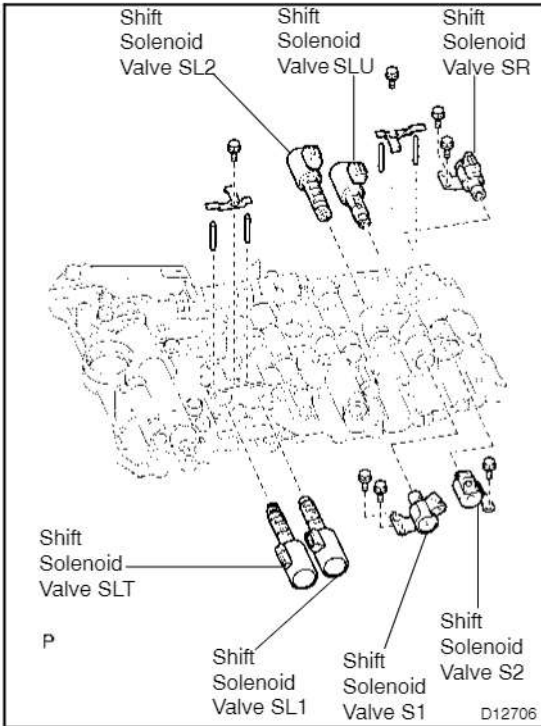

9. REMOVE SOLENOID VALVE

- (a) Remove the 2 bolts and the shift solenoid valve SR.
- (b) Remove the 3 bolts and the shift solenoid valve S1 and S2.
- (c) Remove the 2 bolts, 2 solenoid lock plates and the 4 straight pins.
- (d) Remove the shift solenoid SL2 and the shift solenoid valve SLU.
- (e) Remove the shift solenoid SL1 and the shift solenoid valve SLT.
- (f) Remove the O-ring from the solenoid valve S2.

10. INSTALL SOLENOID VALVE

- (a) Install a new O-ring to shift solenoid valve S2.
- (b) Install the shift solenoid SL1 and the shift solenoid valve SLT.
- (c) Install the shift solenoid SL2 and the shift solenoid valve SLU.
- (d) Install the 4 straight pins and the 2 solenoid lock plates with the 2 bolts.
Torque:6.4 N·m (65 kgf·cm,57 in·lbf)
- (e) Install the shift solenoid valve S1 and S2 with the 2 bolts.
Torque:10 N·m (102 kgf·cm,7 ft·lbf)
- (f) Install the shift solenoid valve SR with the 2 bolts.
Torque:6.4 N·m (65 kgf·cm,5.7 ft·lbf)

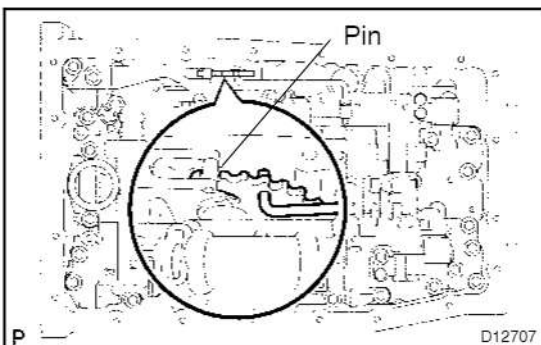

11. INSTALL VALVE BODY

HINT:

- Align the groove of the manual valve with the pin of the lever.
- (a) Install the 3 new drum seal gaskets to the transmission case.

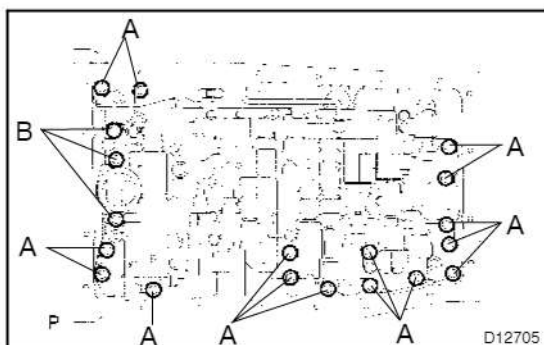

- (b) Install the 19 bolts and the valve body.

Torque:

Bolt A.B: 11 N·m (110 kgf·cm, 8 ft·lbf)

Bolt length:

Bolt A: 25 mm (0.98 in.)

Bolt B: 36 mm (1.42 in.)

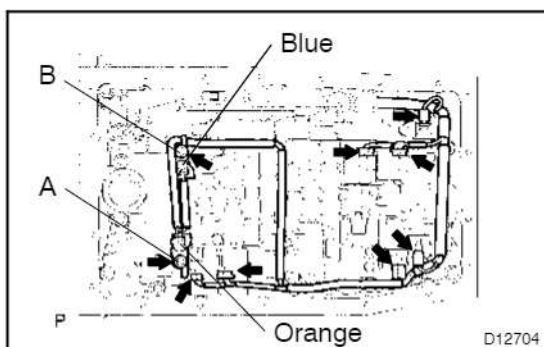

12. CONNECT TEMPERATURE SENSOR

Connect the 2 temperature sensors to the valve body, and install the 2 temperature sensors clamp with the 2 bolts.

Torque:

A: 11 N·m (112 kgf·cm, 8 ft·lbf)

B: 10 N·m (100 kgf·cm, 7 ft·lbf)

Bolt length:

Bolt A: 36 mm (1.42 in.)

Bolt B: 12 mm (0.47 in.)

Sensor wire harness:

Wire harness	Color
for linear control	Orange
for oil temp warning lamp	Blue

13. CONNECT 7 CONNECTORS TO SHIFT SOLENOID VALVES

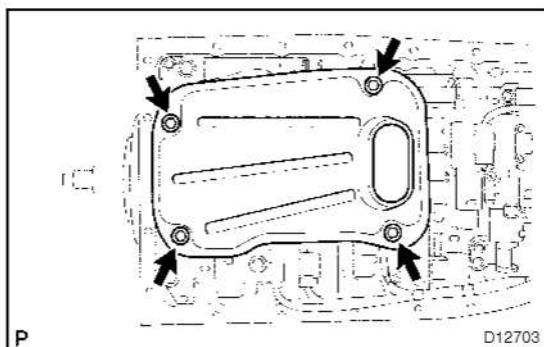

14. INSTALL OIL STRAINER

- (a) Install a new O-ring.

- (b) Install the oil strainer with the 4 bolts.

Torque: 10 N·m (100 kgf·cm, 7 ft·lbf)

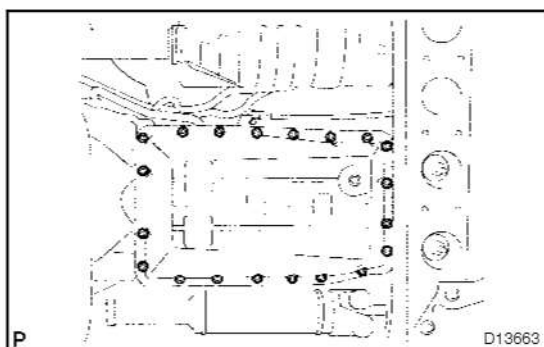

15. INSTALL OIL PAN

HINT:

Remove any packing material, and be careful not to spill oil on the contacting surfaces of the transmission case and the oil pan.

- (a) Install a new gasket and oil pan.

- (b) Install the 20 bolts and oil pan.

Torque: 4.4 N·m (45 kgf·cm, 39 in·lbf)

16. FILL ATF AND CHECK ATF LEVEL

(a) Install a new gasket and a drain plug.

Torque: 20 N·m (205 kgf·cm, 15 ft·lbf)

(b) Remove the refill plug.

(c) Fill new fluid through the filler hole ([See page DI-5](#) or [DI-33](#)).

17. INSTALL ENGINE NO.2 UNDER COVER

AUTOMATIC TRANSMISSION UNIT (2UZ-FE)

COMPONENTS

AT081-03

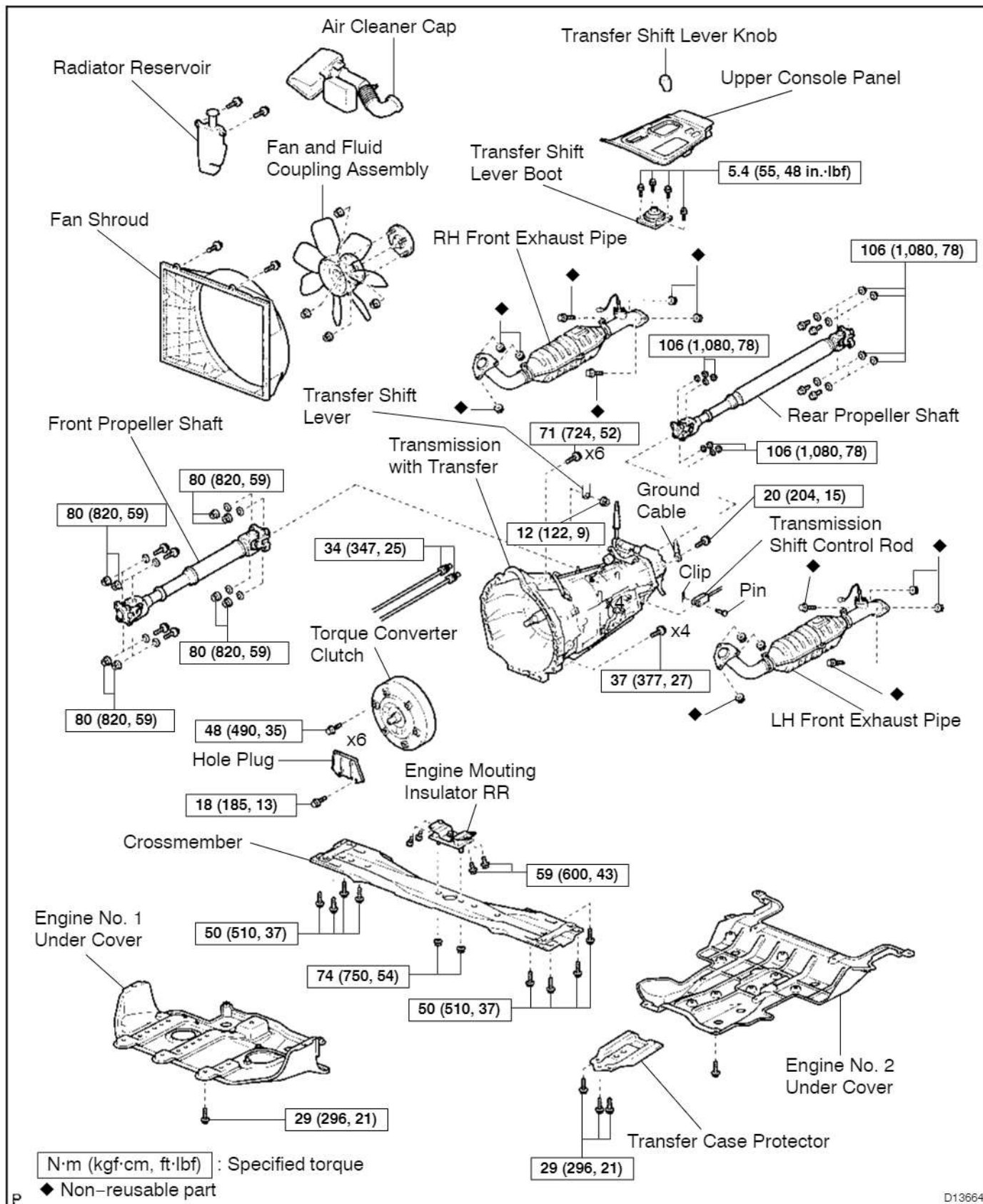

cardiagn.com

D13664

REMOVAL

1. REMOVE BATTERY
2. REMOVE AIR CLEANER CAP DRIVE BELT, FAN AND FLUID COUPLING ASSEMBLY, FAN SHROUD AND RADIATOR RESERVOIR

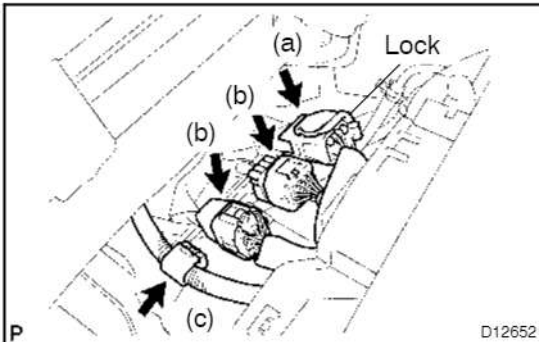

3. DISCONNECT CONNECTORS

- (a) Release the lock and disconnect the transmission wire connector.
- (b) Disconnect the 2 transmission wire connectors.
- (c) Separate the connector clamp.

4. REMOVE TRANSFER SHIFT LEVER BOOT

- (a) Remove the transfer shift lever knob.
- (b) Remove upper console panel (See Pub. No. RM970E, page BO-79).

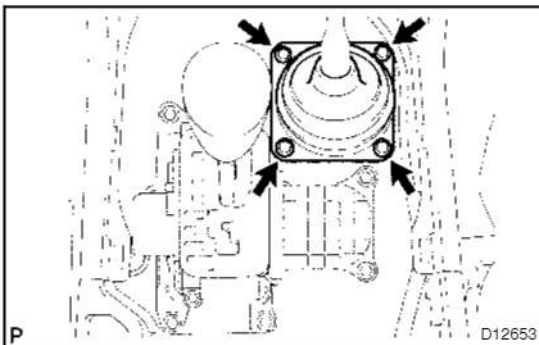

- (c) Remove the 4 bolts and the transfer shift lever boot.

Torque: 5.4 N·m (55 kgf·cm, 48 in·lbf)

5. REMOVE ENGINE NO. 1 AND NO. 2 UNDER COVERS

Torque: 29 N·m (296 kgf·cm, 21 ft·lbf)

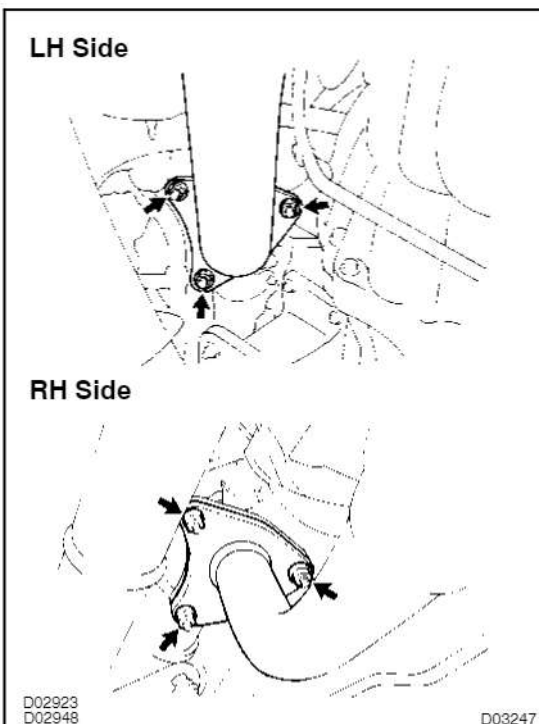

6. REMOVE LH AND RH FRONT EXHAUST PIPE

- (a) Remove the 6 nuts.

Torque: 62 N·m (630 kgf·cm, 46 ft·lbf)

HINT:

After the time of installation, please refer to the following item.
Replace the used nuts with new ones.

- (b) Remove the 4 bolts and nuts.

Torque: 40 N·m (408 kgf·cm, 29 ft·lbf)

HINT:

After the time of installation, please refer to the following item.
Replace the used nuts with new ones.

- (c) Remove the LH and RH front exhaust pipes and 4 gaskets.

HINT:

After the time of installation, please refer to the following item.
Replace the used gaskets with new ones.

7. REMOVE FRONT AND REAR PROPELLER SHAFTS (See Pub. No. RM616E on page PR-4)

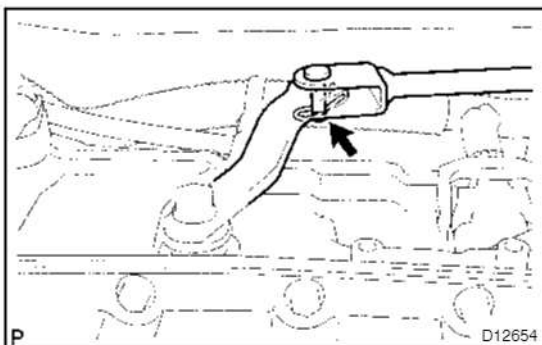
**8. SEPARATE TRANSMISSION SHIFT CONTROL ROD**

Remove the clip and pin and separate the shift control rod.

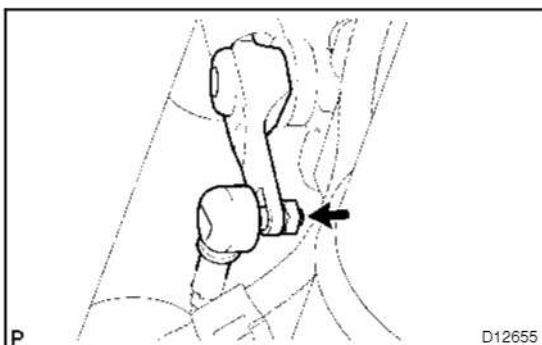
**9. SEPARATE TRANSFER SHIFT LEVER**

Remove the nut and separate the transfer shift lever rod assembly.

Torque: 12 N·m (122 kgf·cm, 9 ft·lbf)

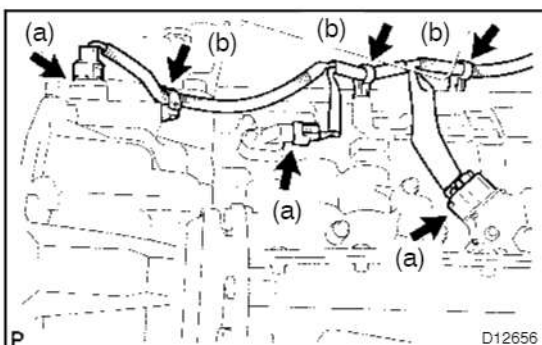
**10. SEPARATE WIRE HARNESS**

- (a) Disconnect 3 connectors.
- (b) Remove the 3 clamps from the transmission unit and separate the transmission wire.

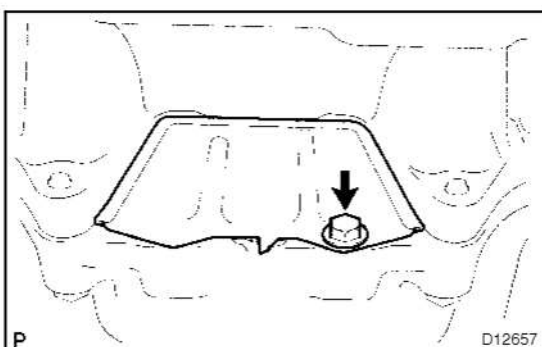
**11. REMOVE TORQUE CONVERTER CLUTCH MOUNTING BOLT**

- (a) Remove the bolt and the hole plug.

Torque: 18 N·m (185 kgf·cm, 13 ft·lbf)

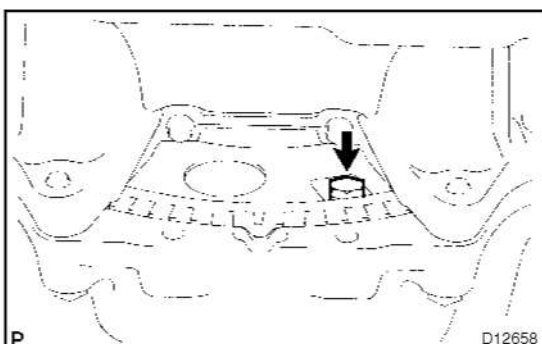

- (b) Turn the crankshaft to gain access to each bolt.
- (c) Hold the crankshaft pulley nut with a wrench, and remove the 6 bolts.

Torque: 48 N·m (490 kgf·cm, 35 ft·lbf)

HINT:

At the time of installation, first install the green colored bolt. And then install the other 5 bolts.

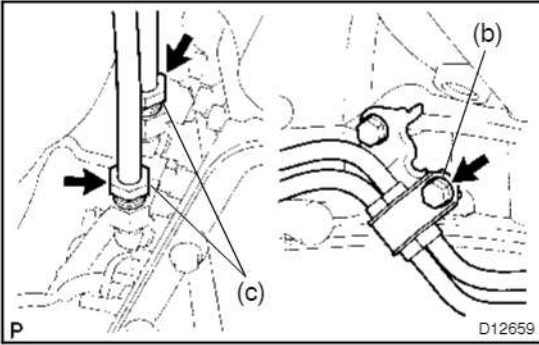

12. DISCONNECT OIL COOLER PIPES

- (a) Loosen the 2 union nuts.
- (b) Remove the bolt and the clamp.
- (c) Remove the 2 union nuts and disconnect the 2 oil cooler pipes.

Torque: 12 N·m (122 kgf·cm, 9 ft·lbf)

Torque: 34 N·m (347 kgf·cm, 25 ft·lbf)

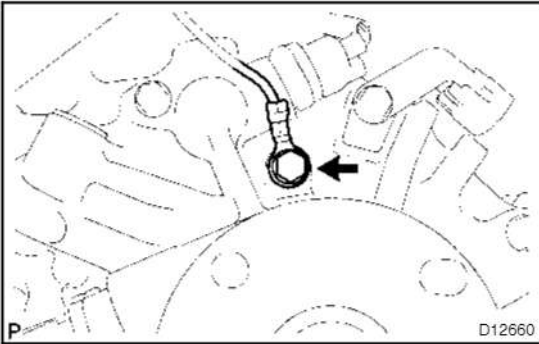

13. SEPARATE GROUND CABLE

Remove the bolt and separate the ground cable.

Torque: 20 N·m (204 kgf·cm, 15 ft·lbf)

14. REMOVE CROSSMEMBER AND TRANSFER CASE PROTECTOR

- (a) Support the transmission with a jack.

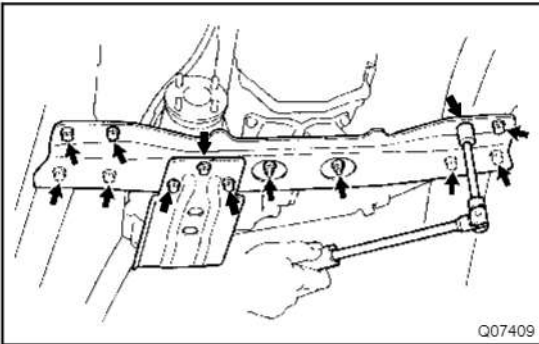

- (b) Remove the 3 bolts and the transfer case protector.

Torque: 29 N·m (296 kgf·cm, 21 ft·lbf)

- (c) Remove the 8 bolts, the 2 nuts and the crossmember.

Torque:

Bolt: 50 N·m (510 kgf·cm, 37 ft·lbf)

Nut: 74 N·m (750 kgf·cm, 54 ft·lbf)

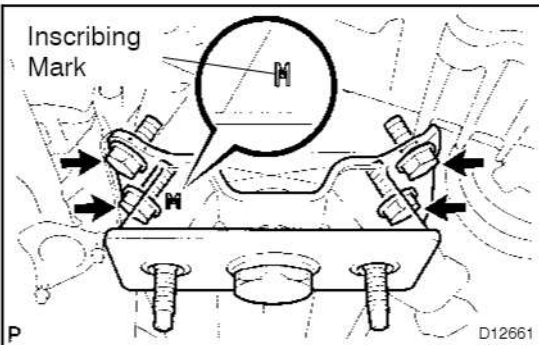

15. REMOVE ENGINE MOUNTING INSULATOR RR

Remove the 4 bolts and the engine mounting insulator RR.

Torque: 59 N·m (600 kgf·cm, 43 ft·lbf)

HINT:

At the time of installation, install the insulator rear with the inscribing mark facing backward.

16. REMOVE TRANSMISSION

- (a) Lower the rear end of the transmission unit.
- (b) Remove the transmission wire clamp bolt.

- (c) Remove the 10 bolts and the transmission unit.

Torque:

Bolt A: 71 N·m (724 kgf·cm, 52 ft·lbf)

Bolt B: 37 N·m (377 kgf·cm, 27 ft·lbf)

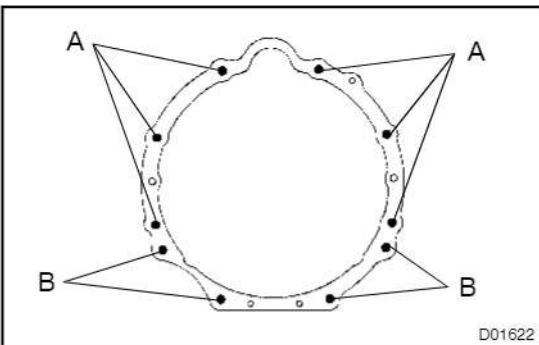

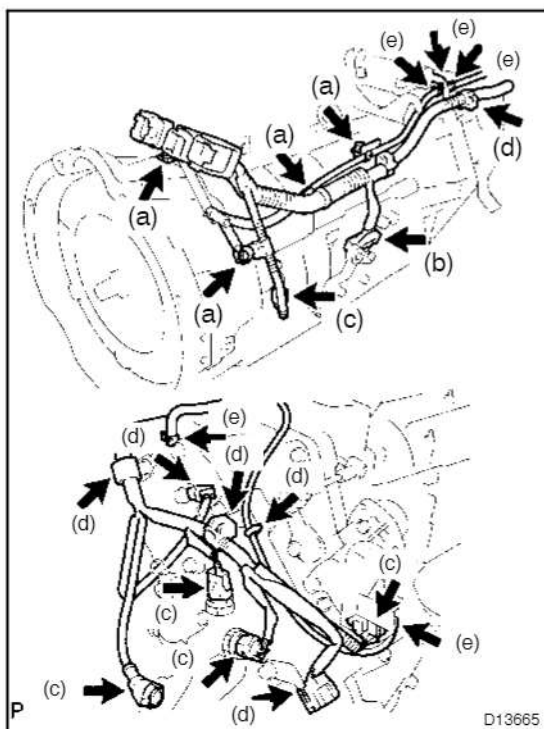
**17. REMOVE WIRE HARNESS AND HOSE**

- (a) Remove the 4 bolts.
Torque: 8.0 N·m (82 kgf·cm, 71 in.·lbf)
- (b) Release the lock and disconnect the connector.
- (c) Disconnect the 5 connectors.
- (d) Separate the 6 connector clamps.
- (e) Disconnect the 5 hoses and remove the wire harness and the hose.



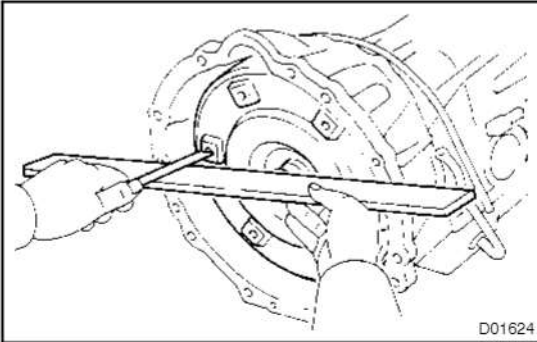

INSTALLATION

1. CHECK TORQUE CONVERTER CLUTCH INSTALLATION

Using calipers and a straight edge, measure the distance from the installed surface of the transmission housing to the installed surface of the torque converter clutch.

Correct distance: More than 17.1 mm (0.673 in.)

2. TRANSMISSION INSTALLATION

Installation is in the reverse order of removal (See page AT-6).

HINT:

- Transmission control rod and park/neutral positionswitch (See page DI-5).
- ATF level (See page DI-5).
- Conduct the road test of the vehicle (See page DI-5).

REMOVAL

1. REMOVE BATTERY
2. REMOVE TRANSFER SHIFT LEVER BOOT
 - (a) Remove the transfer shift lever knob.
 - (b) Remove upper console panel (See Pub. No. RM970E, page BO-79).

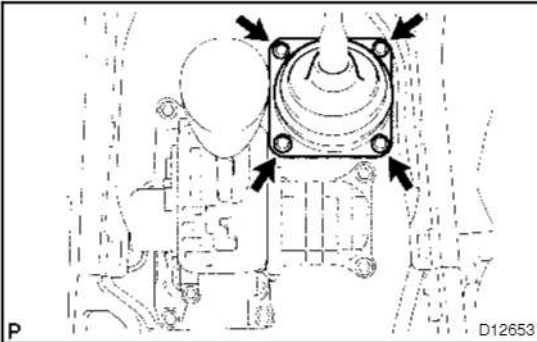

- (c) Remove the 4 bolts and transfer shift lever boot.
Torque: 5.4 N·m (55 kgf·cm, 48 in·lbf)
3. REMOVE ENGINE NO. 1 AND NO. 2 UNDER COVERS
Torque: 29 N·m (296 kgf·cm, 21 ft·lbf)

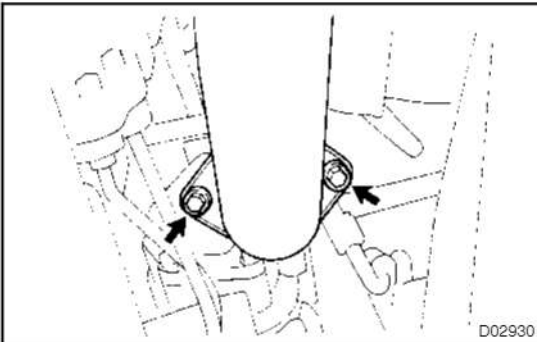

4. REMOVE FRONT EXHAUST PIPES
 - (a) Remove the nuts.
Torque: 62 N·m (630 kgf·cm, 46 ft·lbf)

HINT:

At the time of installation, please refer to the following item.
Replace the used nuts with new ones.

- (b) Remove the 2 bolts.
Torque: 62 N·m (630 kgf·cm, 46 ft·lbf)

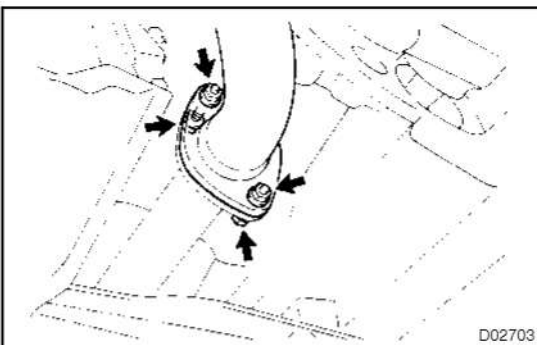

- (c) Remove the 2 bolts and nuts.
Torque: 40 N·m (408 kgf·cm, 29 ft·lbf)

HINT:

At the time of installation, please refer to the following item.
Replace the used nuts with new ones.

5. REMOVE FRONT AND REAR PROPELLER SHAFTS
(See Pub. No. RM616E on page PR-4)

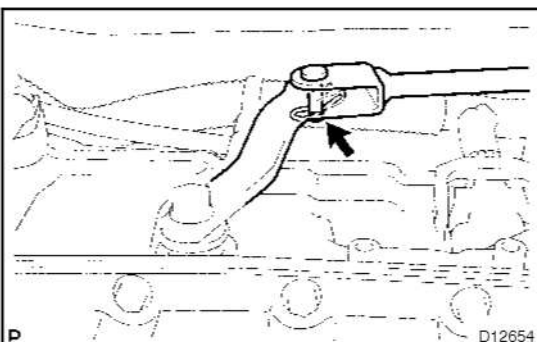

6. SEPARATE TRANSMISSION SHIFT CONTROL ROD
Remove the clip and pin, separate the shift control rod.

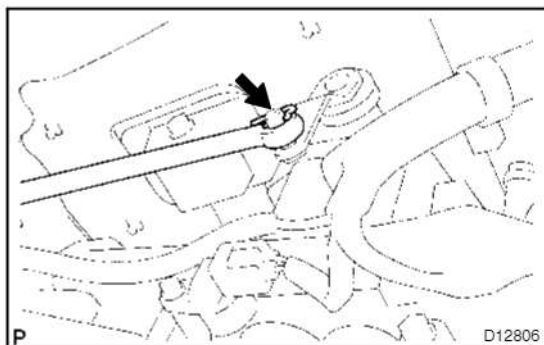

7. SEPARATE TRANSFER SHIFT LEVER

Remove the clip and washer, separate the transfer shift lever rod assembly.

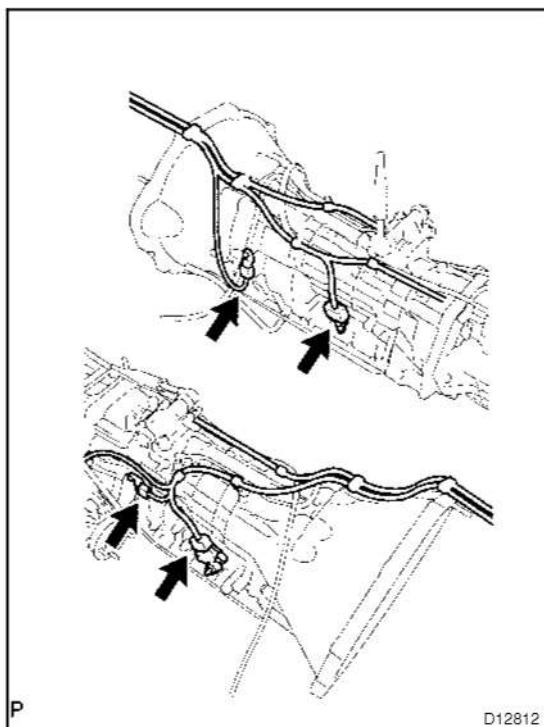

8. SEPARATE WIRE HARNESS

- (a) Transmission side:
Disconnect 4 connectors.

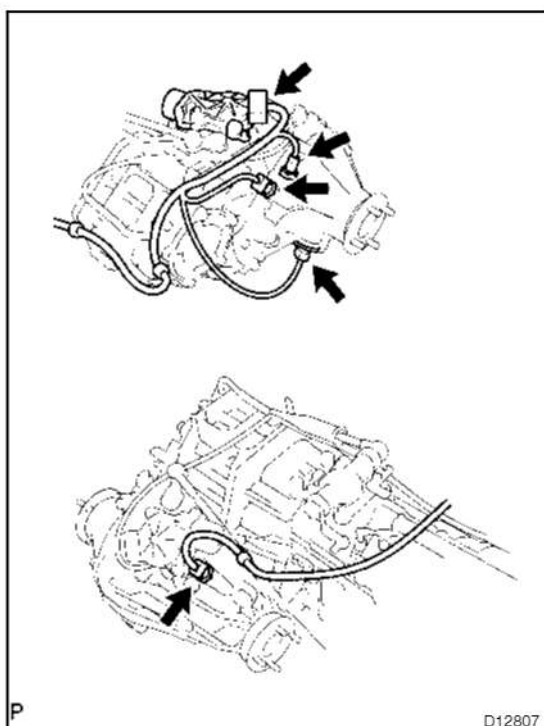

- (b) Transfer side:
(1) Disconnect the 4 connectors.
(2) Disconnect the speed sensor connector.

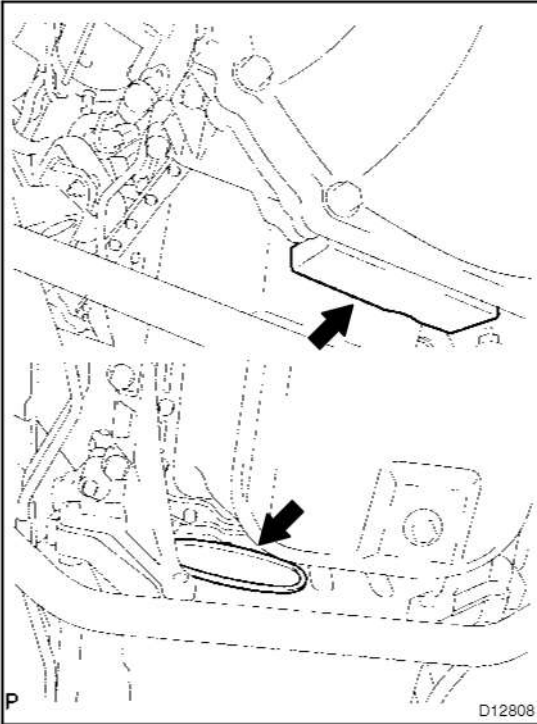

9. REMOVE TORQUE CONVERTER CLUTCH MOUNTING BOLT

- (a) Remove the cylinder block insulator and hole plug.

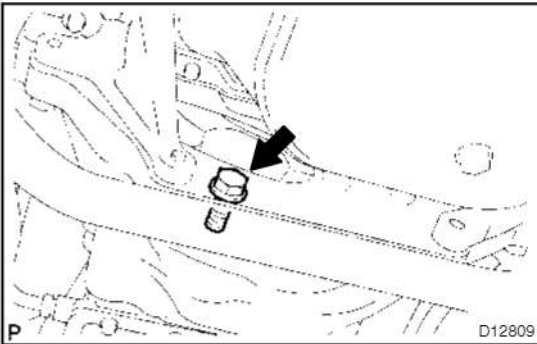

- (b) Turn the crankshaft to gain access to each bolt.
 (c) Hold the crankshaft pulley nut with a wrench and remove the 6 bolts.

Torque: 48 N·m (490 kgf·cm, 35 ft·lbf)

HINT:

At the time of installation, please refer to the following item.
 First install green colored bolt and then 5 other bolts.

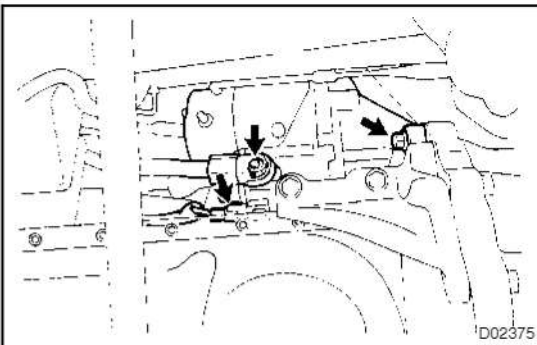

10. REMOVE STARTER

- (a) Remove the nut and disconnect the starter wire and connector.
 (b) Remove the bolt and starter.

Torque: 37 N·m (380 kgf·cm, 27 ft·lbf)

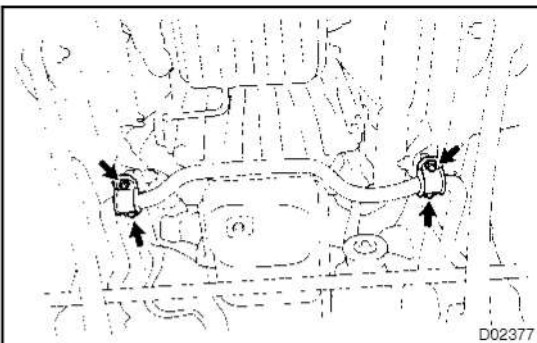

11. REMOVE 4 STABILIZER MOUNTING BOLTS

Torque: 18 N·m (185 kgf·cm, 13 ft·lbf)

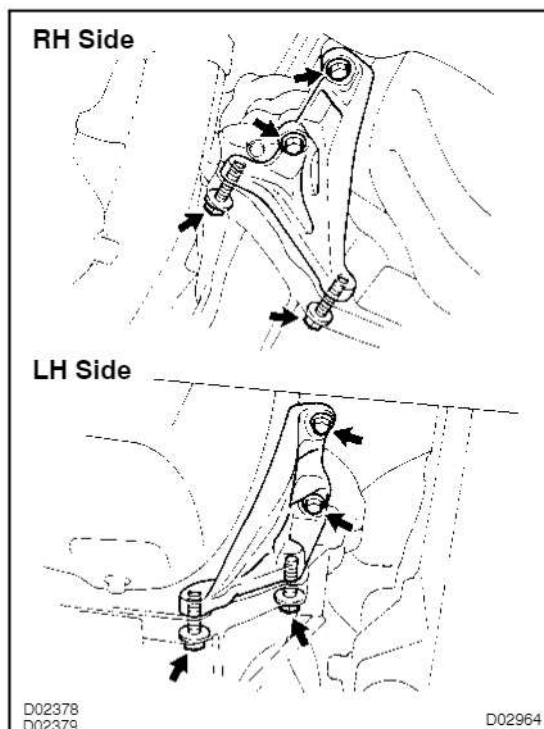
**12. REMOVE LH AND RH STIFFENER PLATE**

Remove the 8 bolts and LH and RH stiffener plates.

Torque: 68 N·m (693 kgf·cm, 50 ft·lbf)

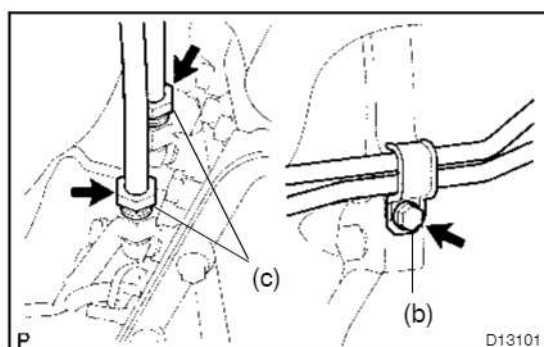
**13. DISCONNECT OIL COOLER PIPES**

(a) Loosen the 2 union nuts.

(b) Remove the bolt and clamp.

Torque: 12 N·m (122 kgf·cm, 9 ft·lbf)

(c) Remove the 2 union nuts, disconnect the 2 oil cooler pipes.

Torque: 34 N·m (347 kgf·cm, 25 ft·lbf)

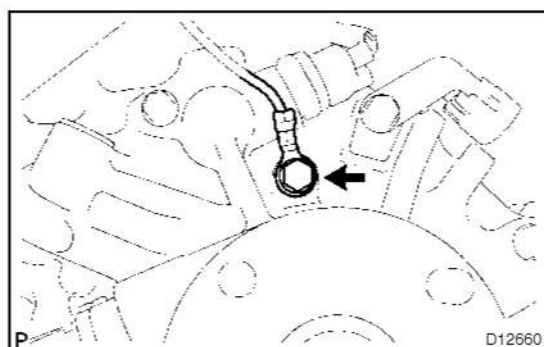
**14. SEPARATE GROUND CABLE**

Remove the bolt, separate the ground cable.

Torque: 8.0 N·m (82 kgf·cm, 71 in·lbf)

15. REMOVE CROSSMEMBER AND TRANSFER CASE PROTECTOR

(a) Support the transmission with a jack.

(b) Remove the 3 bolts and transfer case protector.

Torque: 29 N·m (296 kgf·cm, 21 ft·lbf)

(c) Remove the 8 bolts, 2 nuts and crossmember.

Torque:

Bolt: 50 N·m (510 kgf·cm, 37 ft·lbf)

Nut: 74 N·m (750 kgf·cm, 54 ft·lbf)

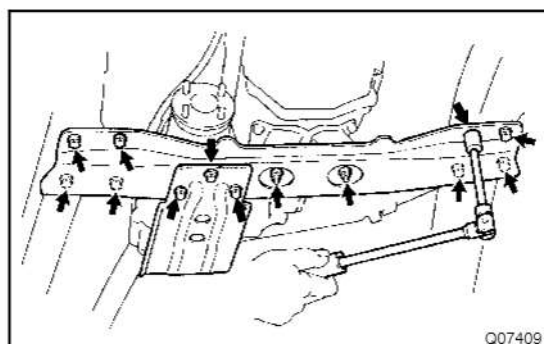

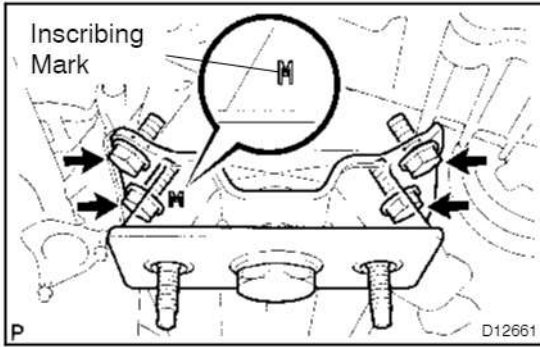
**16. REMOVE ENGINE MOUNTING INSULATOR RR**

Remove the 4 bolts and engine mounting insulator RR.

Torque: 59 N·m (600 kgf·cm, 43 ft·lbf)

HINT:

At the time of installation, install the insulator rear with the inscribing mark facing backward.

17. REMOVE TRANSMISSION

(a) Lower the rear end of the transmission unit.

(b) Remove the transmission wire clamp bolt.

(c) Remove the 4 bolts and transmission unit.

Torque: 71 N·m (724 kgf·cm, 52 ft·lbf)

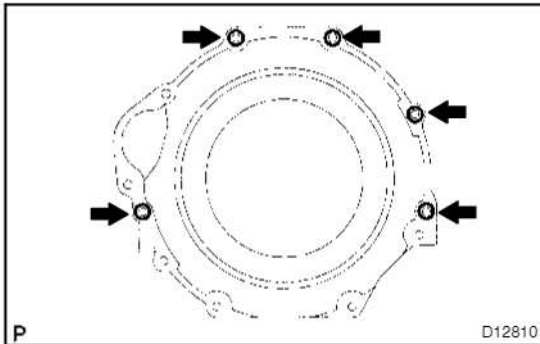

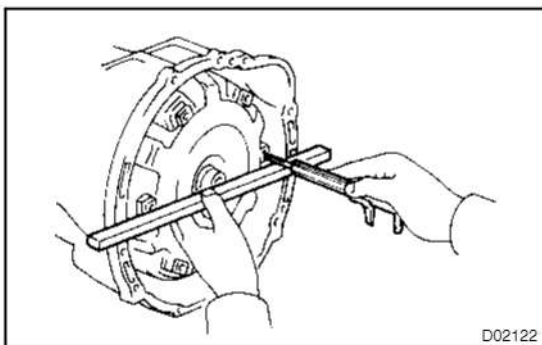

INSTALLATION

1. CHECK TORQUE CONVERTER CLUTCH INSTALLATION

Using calipers and a straight edge, measure the distance from the installed surface of the transmission housing to the installed surface of the torque converter clutch.

Correct distance: More than 43.4 mm (1.710 in.)

2. TRANSMISSION INSTALLATION

Installation is in the reverse order of removal (See page AT-12).

HINT:

- Transmission control rod and park/neutral position switch (See page DI-33).
- ATF level (See page DI-33).
- Conduct the road test of the vehicle (See page DI-33).

TROUBLESHOOTING

VEHICLE PULLING DIAGNOSIS

SA2B-J-03

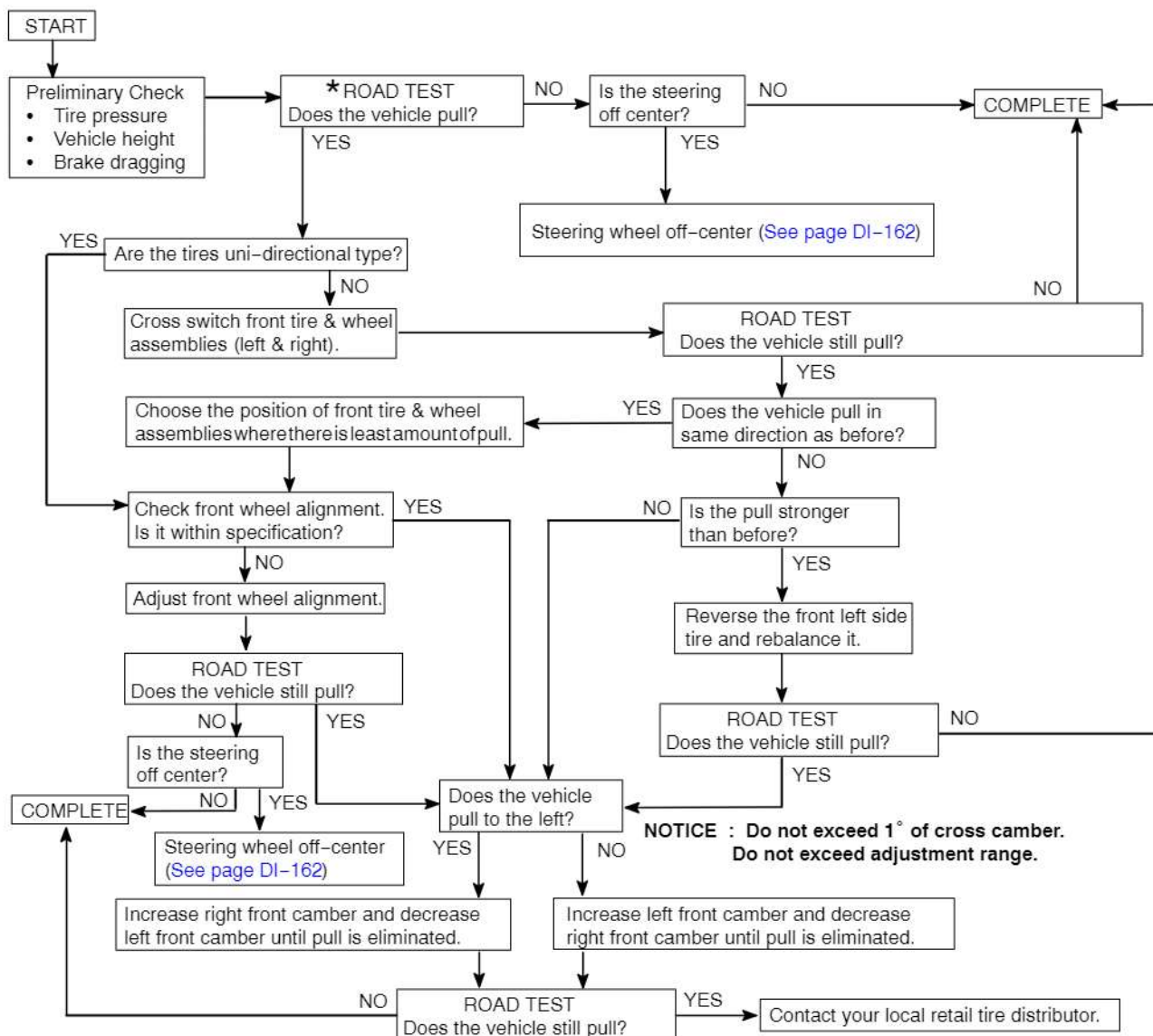

★ Select a flat road where the vehicle can be driven in a straight line for 100 meters at a constant speed of 56 km/h (35mph). Please confirm safety and set the steering wheel to its straight position. Drive the vehicle in a straight line for 100 meters at a constant speed of 35mph without holding the steering wheel.

- (1) The vehicle can keep straight but the steering wheel has some angle.
→ STEERING OFF CENTER (See page DI-162)
- (2) The vehicle cannot keep straight.
→ STEERING PULL

FRONT WHEEL ALIGNMENT INSPECTION

SA171-08

NOTICE:

After adjusting wheel alignment perform the VGRS calibration.

HINT:

- For the steering wheel off-center, perform the "steering off-center" (See page DI-162).
- Check that the "STRAIGHT ANG FLG" is "VALID" in the DATA LIST (See page DI-91 step 5.).

1. MEASURE VEHICLE HEIGHT

Vehicle height EUROPE

Engine	Front	Rear
2UZ-FE	A - B: 75.0 mm (2.953 in.)	C - D: 40.0 mm (1.575 in.)
1HD-FT	A - B: 76.0 mm (2.992 in.)	C - D: 41.0 mm (1.614 in.)

GENERAL

Engine	Front	Rear
2UZ-FE	A - B: 76.0 mm (2.992 in.)	C - D: 31.0 mm (1.220 in.)
1HD-T	A - B: 76.0 mm (2.992 in.)	C - D: 34.0 mm (1.339 in.)

G.C.C.

Engine	Front	Rear
2UZ-FE	A - B: 72.0 mm (2.835 in.)	C - D: 53.0 mm (2.087 in.)
1FZ-FE	A - B: 71.0 mm (2.795 in.)	C - D: 64.0 mm (2.520 in.)

AUSTRALIA

Front	A - B: 75.0 mm (2.953 in.)
Rear	C - D: 39.0 mm (1.535 in.)

w/ AHC System

Front	A - B: 83.0 mm (3.268 in.)
Rear	C - D: 71.0 mm (2.795 in.)

Measuring points:

A: Ground clearance of spindle center

B: Ground clearance of lower suspension arm front bolt center

C: Ground clearance of rear axle shaft center

D: Ground clearance of lower control arm front bolt center

NOTICE:

Before inspecting the wheel alignment, adjust the vehicle height to the specification.

If the vehicle height is not within the specification, try to adjust it by pushing down on or lifting the body.

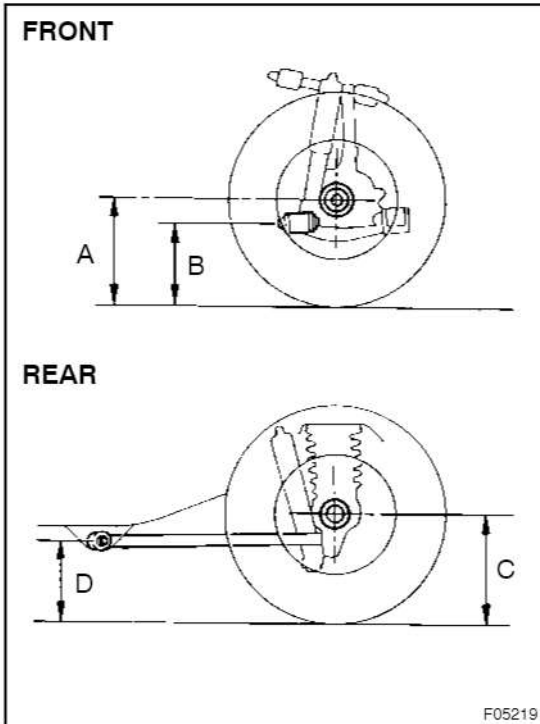

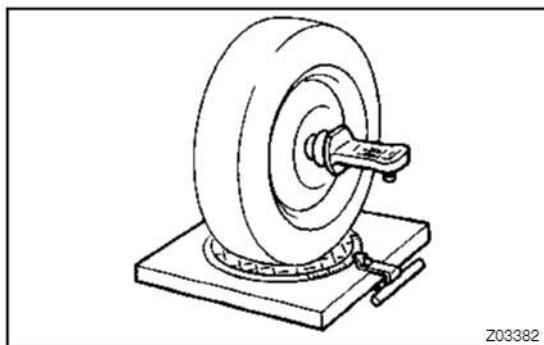

2. INSTALL CAMBER-CASTER-KINGPIN GAUGE OR POSITION VEHICLE ON WHEEL ALIGNMENT TESTER

Follow the specific instructions of the equipment manufacturer.

3. INSPECT CAMBER, CASTER AND STEERING AXIS INCLINATION EUROPE AND GENERAL (2UZ-FE)

Camber	$0^{\circ}05' \pm 45'$ ($0.08^{\circ} \pm 0.75^{\circ}$)
Left-right error	30' (0.5°) or less
Caster	$2^{\circ}10' \pm 45'$ ($2.17^{\circ} \pm 0.75^{\circ}$)
Left-right error	30' (0.5°) or less
Steering axis inclination	$12^{\circ}10' \pm 45'$ ($12.17^{\circ} \pm 0.75^{\circ}$)
Left-right error	30' (0.5°) or less

GENERAL (1HD-T)

Camber	$0^{\circ}05' \pm 45'$ ($0.08^{\circ} \pm 0.75^{\circ}$)
Left-right error	30' (0.5°) or less
Caster	$2^{\circ}25' \pm 45'$ ($2.42^{\circ} \pm 0.75^{\circ}$)
Left-right error	30' (0.5°) or less
Steering axis inclination	$12^{\circ}10' \pm 45'$ ($12.17^{\circ} \pm 0.75^{\circ}$)
Left-right error	30' (0.5°) or less

G.C.C. (2UZ-FE)

Camber	$0^{\circ}05' \pm 45'$ ($0.08^{\circ} \pm 0.75^{\circ}$)
Left-right error	30' (0.5°) or less
Caster	$2^{\circ}15' \pm 45'$ ($2.25^{\circ} \pm 0.75^{\circ}$)
Left-right error	30' (0.5°) or less
Steering axis inclination	$12^{\circ}10' \pm 45'$ ($12.17^{\circ} \pm 0.75^{\circ}$)
Left-right error	30' (0.5°) or less

G.C.C. (1FZ-FE)

Camber	$0^{\circ}05' \pm 45'$ ($0.08^{\circ} \pm 0.75^{\circ}$)
Left-right error	30' (0.5°) or less
Caster	$2^{\circ}50' \pm 45'$ ($2.83^{\circ} \pm 0.75^{\circ}$)
Left-right error	30' (0.5°) or less
Steering axis inclination	$12^{\circ}10' \pm 45'$ ($12.17^{\circ} \pm 0.75^{\circ}$)
Left-right error	30' (0.5°) or less

AUSTRALIA

Camber	$0^{\circ}05' \pm 45'$ ($0.08^{\circ} \pm 0.75^{\circ}$)
Left-right error	30' (0.5°) or less
Caster	$2^{\circ}10' \pm 45'$ ($2.17^{\circ} \pm 0.75^{\circ}$)
Left-right error	30' (0.5°) or less
Steering axis inclination	$12^{\circ}10' \pm 45'$ ($12.17^{\circ} \pm 0.75^{\circ}$)
Left-right error	30' (0.5°) or less

w/ AHC System

Camber	$0^{\circ}00' \pm 45'$ ($0^{\circ} \pm 0.75^{\circ}$)
Left-right error	30' (0.5°) or less
Caster	$3^{\circ}05' \pm 45'$ ($3.08^{\circ} \pm 0.75^{\circ}$)
Left-right error	30' (0.5°) or less
Steering axis inclination	$12^{\circ}15' \pm 45'$ ($12.25^{\circ} \pm 0.75^{\circ}$)
Left-right error	30' (0.5°) or less

If the steering axis inclination is not within the specification, after the camber and caster have been correctly adjusted, recheck the steering knuckle front wheel for bearing or looseness.

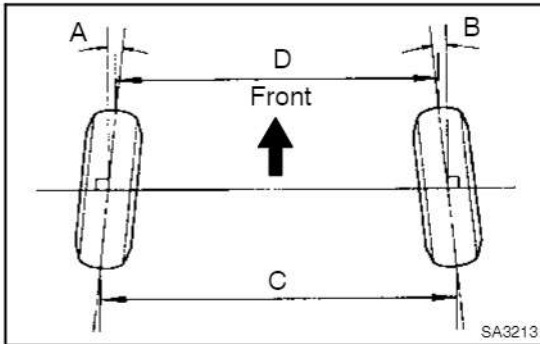

4. INSPECT TOE-IN w/ AHC System

Toe-in (total)	A + B: $0^{\circ}00' \pm 12'$ ($0^{\circ} \pm 0.2^{\circ}$) C - D: 0 ± 2 mm (0 ± 0.08 in.)
-------------------	--

OTHERS

Toe-in (total)	A + B: $0^{\circ}06' \pm 12'$ ($0.1^{\circ} \pm 0.2^{\circ}$) C - D: 1 ± 2 mm (0.04 ± 0.08 in.)
-------------------	---

If the toe-in is not within the specification, adjust the rack ends.

5. ADJUST CAMBER AND CASTER

NOTICE:

After the camber has been adjusted, inspect the toe-in.

- Loosen the front and/or rear adjusting cam nuts.
- Adjust the camber and caster by front and/or rear adjusting cams.

(Example)

- Camber
- - - Caster
- = Calculated value
- = 0 point

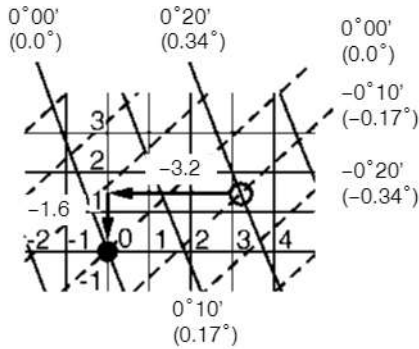

F05095

(c) How to read adjustment chart (using examples).

(1) Measure the present alignment.

Camber: -0°20' (-0.33°)

Caster: 3°15' (3.25°)

(2) Mark the difference between the standard value (A) and the measured value (B) on the adjustment chart.

Standard value:

Camber: 0°00' (0°)

Caster: 3°05' (3.08°)

Formula: A - B = C

Camber: 0°00' - (-0°20') = 0°20'

Caster: 3°05' - 3°15' = -0°10'

(3) As shown in the chart, read the distance from the marked point to 0 point, and adjust the front and/or rear adjusting cams accordingly.

Front cam: - (Shorter) 1.6

Rear cam: - (Shorter) 3.2

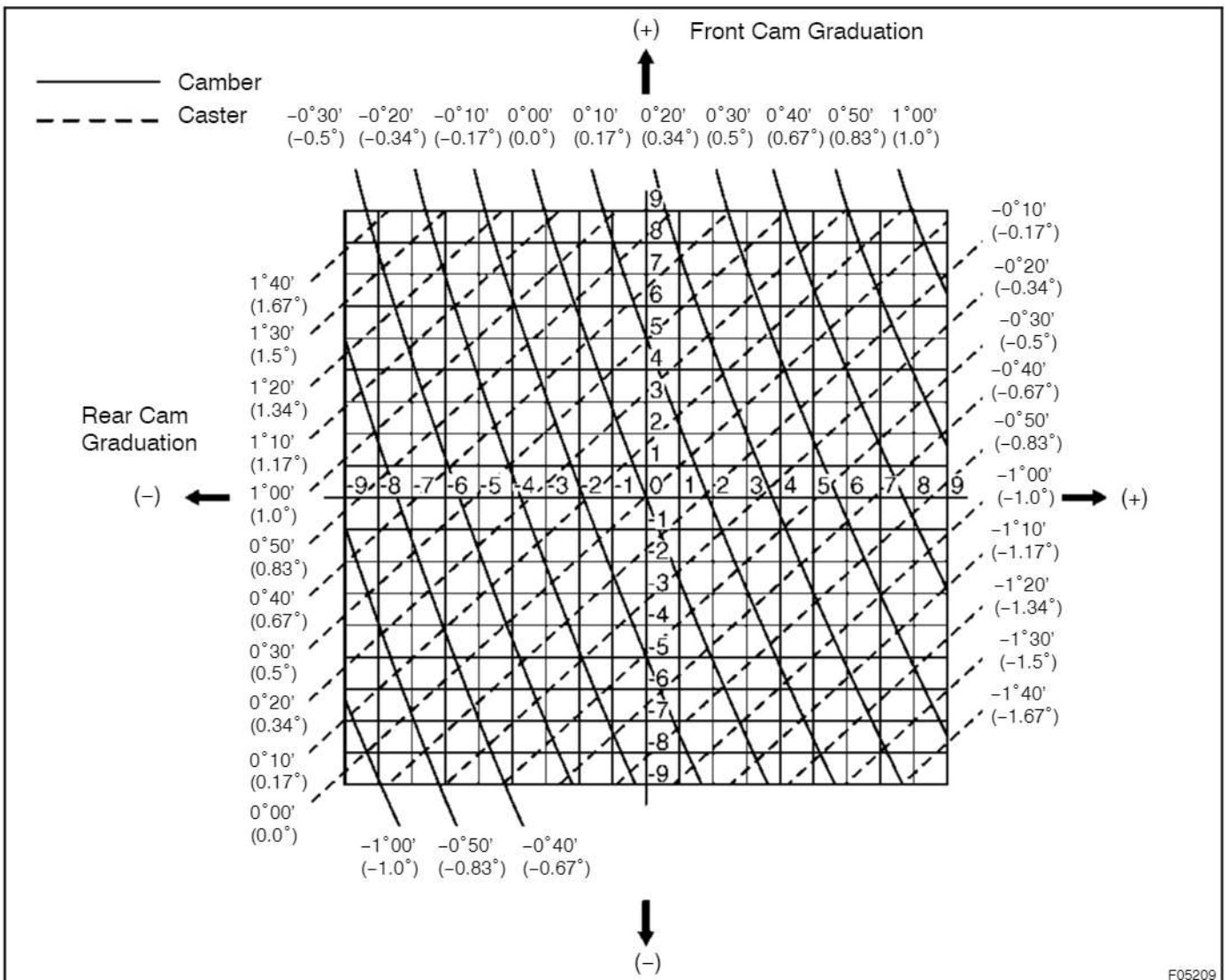

F05209

- (d) Torque the front and/or rear adjusting cam nuts.
Torque: 98 N·m (1,000 kgf·cm, 72 ft·lbf)

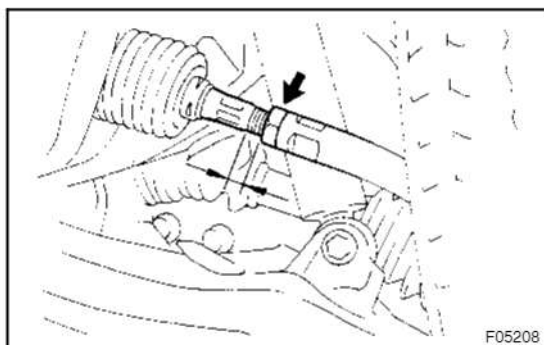

6. ADJUST TOE-IN

NOTICE:

After adjusting wheel alignment perform the VGRS calibration.

- (a) Check or adjust the lengths of the rack ends, then adjust the toe-in.
Rack end length difference: 3.0 mm (0.118 in.) or less
- (b) Remove the boot clamps.
- (c) Loosen the tie rod lock nuts.
- (d) Turn the left and right rack ends an equal amount to adjust the toe-in.

HINT:

Try to adjust the toe-in to the center value.

- (e) Tighten the tie rod lock nuts.
- (f) Place the boot on the seat and clamp it.

HINT:

Make sure that the boots are not twisted.

- (g) Perform the VGRS system calibration ([See page DI-100](#)).
- (h) Perform the zero point calibration of yaw rate and deceleration sensor ([See Pub No. RM970E, page DI-185](#)).

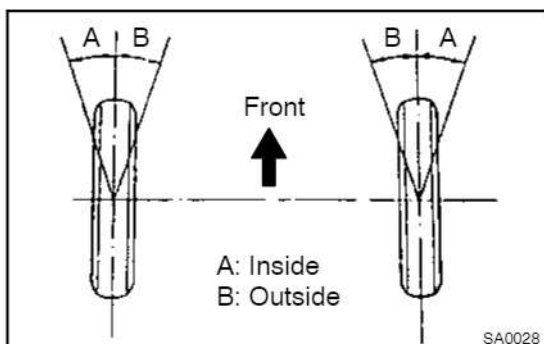

7. INSPECT AND ADJUST WHEEL ANGLE

- (a) Turn the steering wheel fully, and measure the turning angle.

Inside wheel	36°42' (33°42' - 36°42') 36.7° (33.7° - 36.7°)
Reference: Outside wheel	32°36' 32.6°

If the wheel angles differ from the standard of the specification, inspect the toe-in.

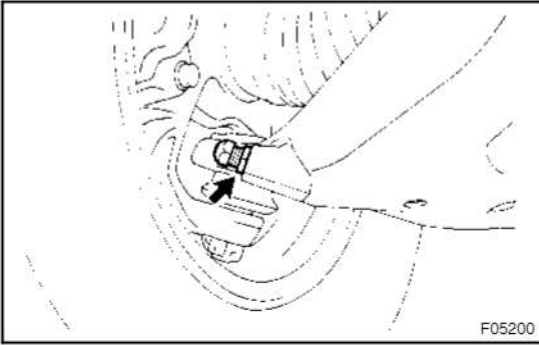

- (b) When toe-in is normal after inspection, adjust wheel angle with the knuckle stopper bolt of the lower suspension arm.

Torque: 44 N·m (450 kgf·cm, 32 ft·lbf)

STEERING WHEEL REPAIR PROCEDURES

SR1HO-18

HINT:

- For the steering off-center, perform the "steering off-center" (See page DI-162).
- Check that the "STRAIGHT ANG FLG" is "VALID" in the DATA LIST (See page DI-91 step 5.).
- This is the repair procedure for steering off center.

1. INSPECT STEERING WHEEL OFF CENTER

- (a) Apply masking tape on the top center of the steering wheel and steering column upper cover.

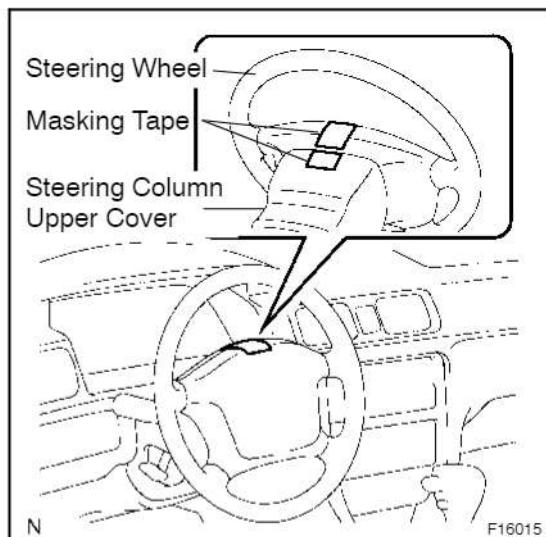

- (b) Drive the vehicle in a straight line for 100 meters at a constant speed of 35 mph (56 km/h), and hold the steering wheel to maintain the course.
- (c) Draw a line on the masking tape as shown in the illustration.

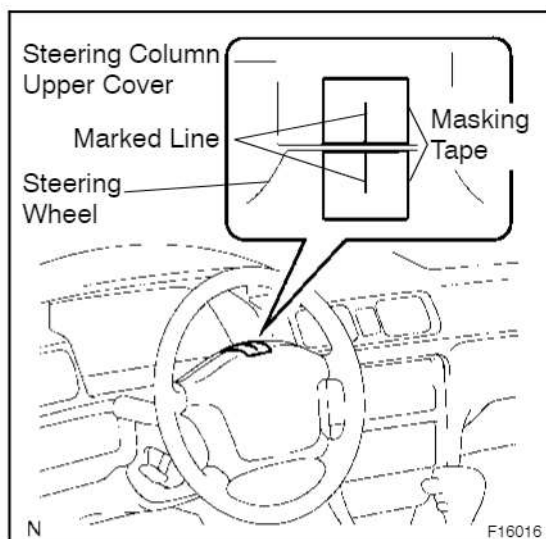

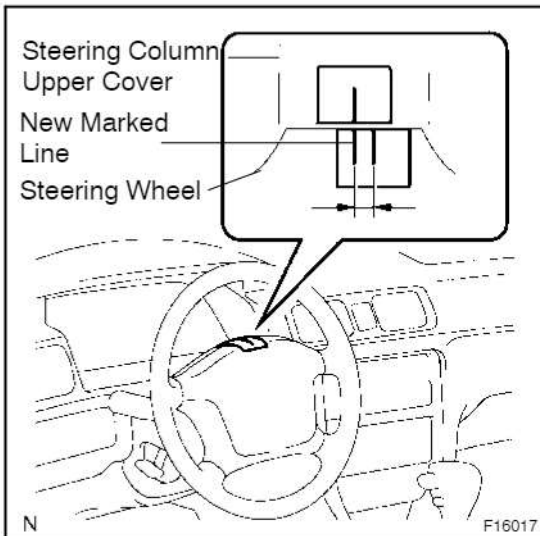

(d) Turn the steering wheel to its straight position.

HINT:

Refer to the upper surface of the steering wheel, steering spoke and SRS airbag line for the straight position.

(e) Draw a new line on the masking tape of the steering wheel as shown in the illustration.

(f) Measure the distance between the 2 lines on the masking tape of the steering wheel.

(g) Convert the measured distance to steering angle.

Measured distance 1 mm (0.04 in.) = Steering angle approximately 1 deg.

HINT:

Make a note of the steering angle.

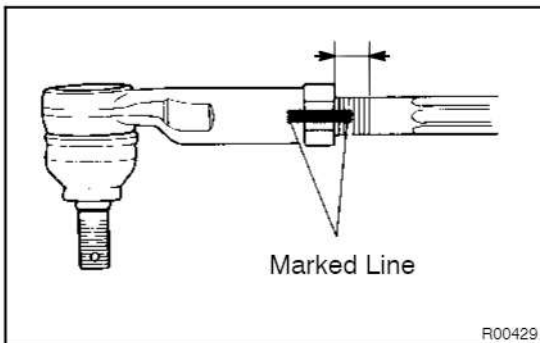

2. ADJUST STEERING ANGLE

(a) Draw a line on the RH and LH tie rod and rack ends where it can easily be seen.

(b) Using a paper gauge, measure the distance from RH and LH tie rod ends to the rack end screws.

HINT:

- Measure the RH side and LH side.
- Make a note of the measured values.

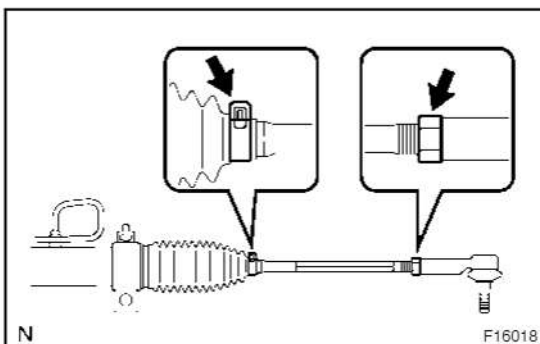

(c) Remove the RH and LH boot clips from the rack boots.

(d) Loosen the RH and LH lock nuts.

(e) Turn the RH and LH rack end by the same amount (but in different directions) according to the steering angle.

1 turn 360 deg. of rack end (1.5 mm (0.059 in.) horizontal movement) = 12 deg. of steering angle

(f) Tighten the RH and LH lock nuts.

Torque: 55 N·m (560 kgf·cm, 41 ft·lbf)

NOTICE:

Make sure that the difference in length between RH and LH tie rod ends and rack end screws are within 3.0 mm (0.118 in.).

(g) Install the RH and LH boot clips.

(h) Perform the steering angle adjustment ([See page DI-100](#) step 4 to 7).

(i) Perform the zero point calibration of yaw rate and deceleration sensors ([See Pub. No. RM970E](#), page DI-185).

POWER TILT AND POWER TELESCOPIC STEERING COLUMN COMPONENTS

SR0FF-02

w/ VGRS:

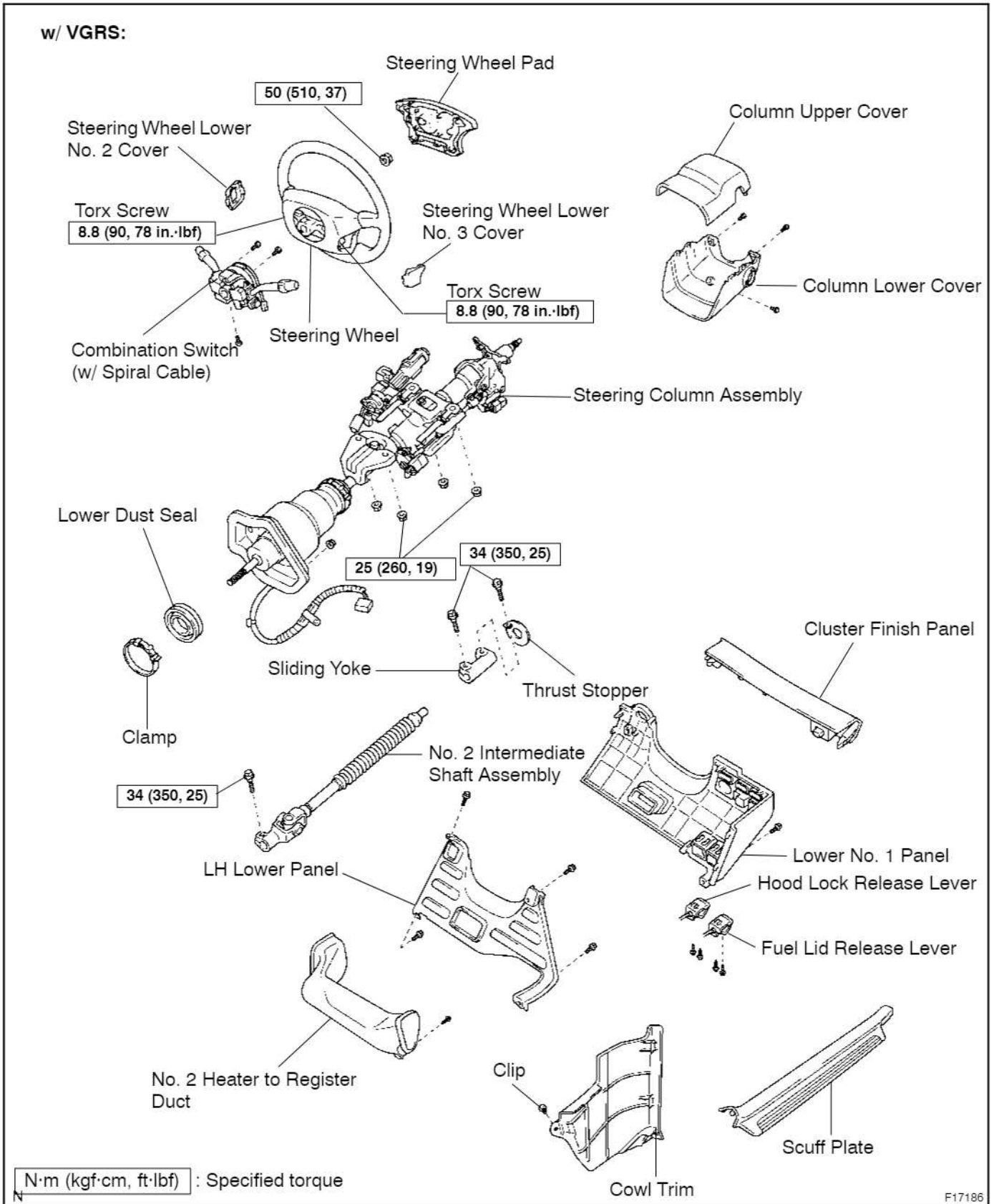

cardiagn.com

F17186

REMOVAL

1. REMOVE STEERING WHEEL PAD

NOTICE:

If the airbag connector is disconnected with the ignition switch at ON or ACC, DTCs will be recorded.

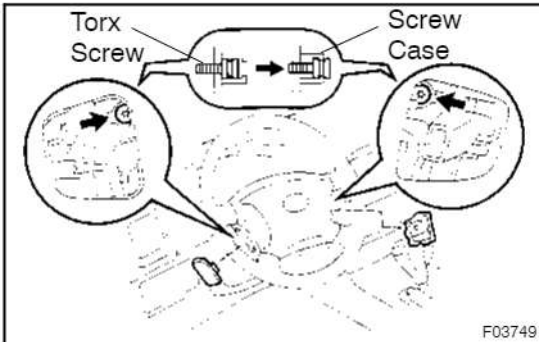

- (a) Place the front wheels facing straight ahead.
- (b) Remove the steering wheel lower No. 2 and No. 3 covers.
- (c) Using a torx socket wrench, loosen the 2 torx screws.

HINT:

Loosen the 2 screws until the groove along the screw circumference catches on the screw case.

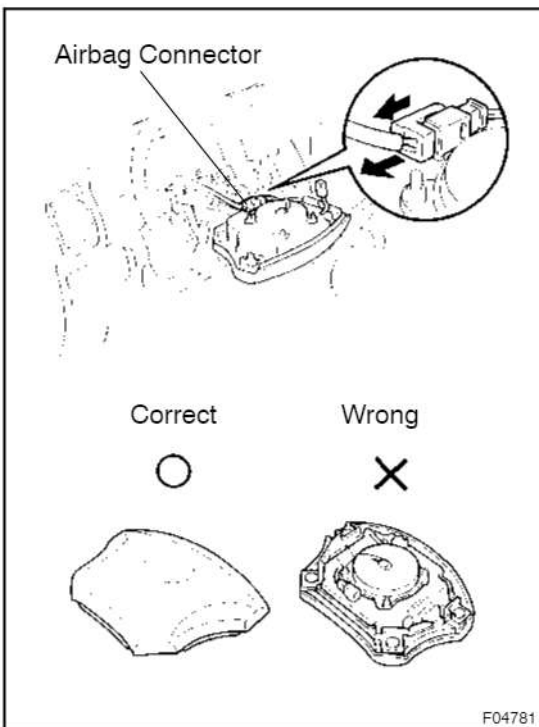

- (d) Except Dual-stage Airbag:
Pull out the wheel pad from the steering wheel and disconnect the airbag connector.
- (e) Except Dual-stage Airbag:
Disconnect the connector.

CAUTION:

- When storing the wheel pad, keep the upper surface of the pad facing upward.
- Never disassemble the wheel pad.

NOTICE:

When removing the wheel pad, take care not to pull the airbag wire harness.

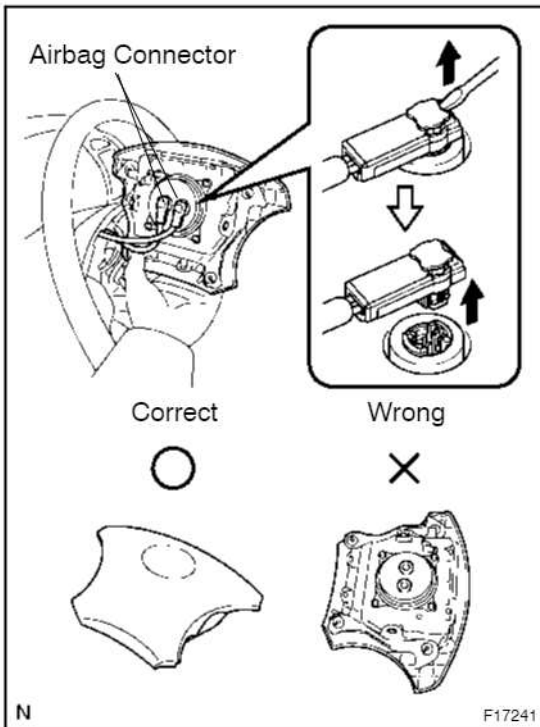

- (f) Dual-stage Airbag:
Pull the pad out from the steering wheel and disconnect the airbag connector.
- (g) Dual-stage Airbag:
Disconnect the connector.

CAUTION:

- When storing the wheel pad, keep the upper surface of the pad facing upward.
- Never disassemble the wheel pad.

NOTICE:

When removing the wheel pad, take care not to pull the airbag wire harness.

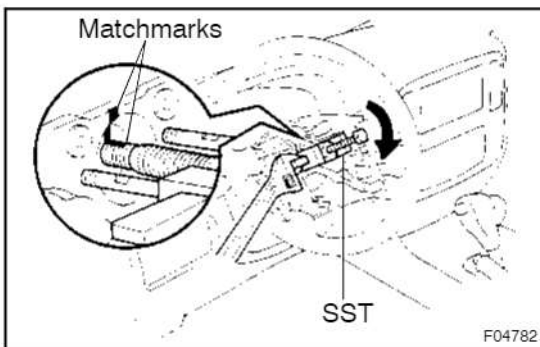
**2. REMOVE STEERING WHEEL**

- (a) Disconnect the connector.
- (b) Remove the steering wheel set nut.
- (c) Place matchmarks on the steering wheel and main shaft assembly.
- (d) Using SST, remove the wheel.
SST 09950-50013 (09951-05010, 09952-05010, 09953-05020, 09954-05021)

3. REMOVE UPPER AND LOWER COLUMN COVERS

Remove the 3 screws.

4. REMOVE COMBINATION SWITCH WITH SPIRAL CABLE

- (a) Disconnect the 5 connectors.
- (b) Disconnect the airbag connector.
- (c) Remove the 3 screws.

5. REMOVE SPIRAL CABLE**NOTICE:**

Do not disassembly the cable or apply oil to it.

6. REMOVE SCUFF PLATE**7. REMOVE COWL TRIM**

Remove the clip.

8. REMOVE CLUSTER FINISH PANEL

Remove the connector.

9. REMOVE LOWER NO. 1 PANEL

- (a) Remove the 2 screws and disconnect the hood lock release lever from the panel.
- (b) Remove the 2 screws and disconnect the fuel lid release lever from the panel.
- (c) Remove pad set screw.

10. REMOVE LH LOWER PANEL

Remove the 4 bolts.

11. REMOVE NO. 2 HEATER TO REGISTER DUCT

Remove the screw.

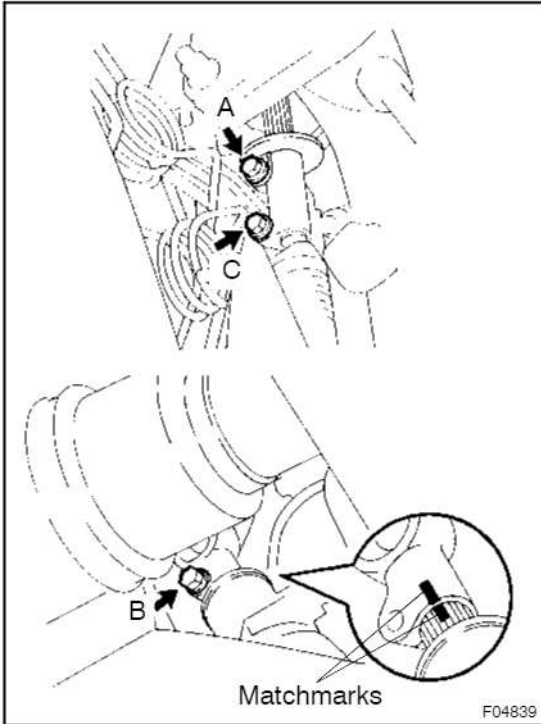

12. DISCONNECT NO. 2 INTERMEDIATE SHAFT ASSEMBLY

- (a) Place matchmarks on the intermediate shaft and control valve shaft.
- (b) Loosen the bolt A.
- (c) Remove the bolt B and the bolt C.

13. w/o VGRS:

DISCONNECT HOLE COVER

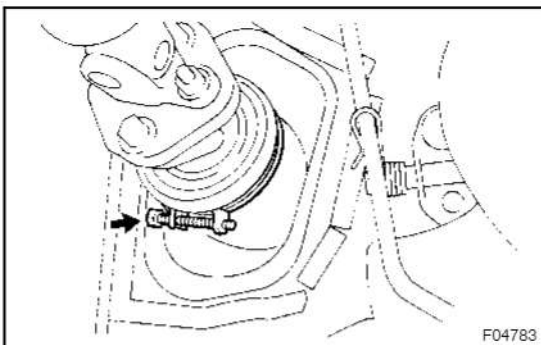

14. w/o VGRS:

REMOVE STEERING COLUMN ASSEMBLY

- (a) Loosen the hose clamp.
- (b) Remove the 4 bolts.
- (c) Disconnect the connectors from column assembly.
- (d) Remove the 4 column assembly set nuts.
- (e) Remove the steering column assembly.

15. w/ VGRS:

REMOVE STEERING COLUMN ASSEMBLY

- (a) Disconnect the connectors from column assembly.
- (b) Disconnect the connector from VGRS ECU.
- (c) Disconnect the VGRS wire harness clamp.
- (d) Remove the 2 nuts from hole cover.
- (e) Remove the 4 column assembly set nuts.
- (f) Remove the steering column assembly.

16. REMOVE NO. 2 INTERMEDIATE SHAFT ASSEMBLY

17. REMOVE SLIDING YOKE

- (a) Remove the bolt.
- (b) Remove the thrust stopper, and sliding yoke.

18. REMOVE LOWER DUST SEAL

Remove the clamp.

19. w/o VGRS:

**REMOVE HOLE COVER, HOSE CLAMP AND NO.2
HOLE COVER FROM COLUMN ASSEMBLY**

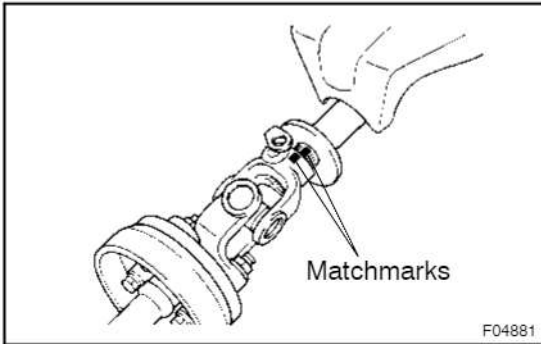

DISASSEMBLY

NOTICE:

When using a vise, do not overtighten it.

1. w/o VGRS:

REMOVE NO. 2 LOWER COVER

Remove the 2 nuts and No. 2 lower cover.

2. w/o VGRS:

REMOVE INTERMEDIATE SHAFT ASSEMBLY

(a) Place matchmarks on the intermediate shaft assembly and main shaft assembly.

(b) Remove the bolt and disconnect the intermediate shaft assembly.

(c) Remove the thrust stopper.

3. w/o VGRS:

REMOVE NO. 2 LOWER COVER

4. w/ VGRS:

REMOVE VGRS ACTUATOR

(a) Loosen the boot clamp.

(b) Remove the bolt and place matchmarks on the intermediate shaft assembly and main shaft assembly.

(c) Disconnect the VGRS assembly with hole cover.

(d) Remove the thrust stopper.

(e) Disconnect VGRS wire harness clamp from the plate.

(f) Remove the boot from the VGRS actuator assembly.

(g) Remove the No. 2 lower cover.

5. REMOVE TRANSPONDER KEY COIL AND KEY CYLINDER LAMP ASSEMBLY

Remove the screw and transponder key coil with the key cylinder lamp assembly.

6. REMOVE CONNECTOR BRACKET

Remove the bolt and connector bracket.

7. REMOVE STEERING COLUMN PROTECTOR NO. 1

Remove the bolt and steering column protector No. 1.

8. REMOVE TURN SIGNAL BRACKET

Remove the 3 bolts and turn signal bracket.

9. REMOVE POWER TILT MOTOR

(a) Using a hexagon wrench, remove the support stopper bolt.

(b) Remove the stopper spring and stopper No. 1.

(c) Using a hexagon wrench, remove the 2 tilt steering bolts.

(d) Using a screwdriver, remove the 2 E-rings.

(e) Remove the 2 support stopper bolt bushings from the motor.

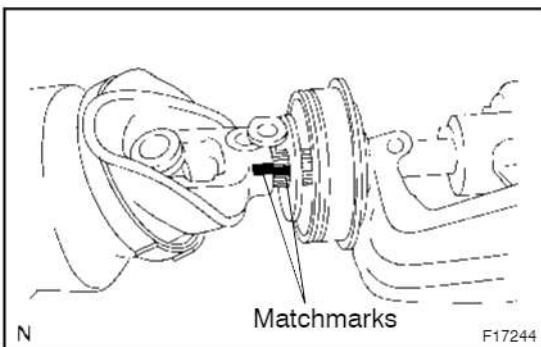

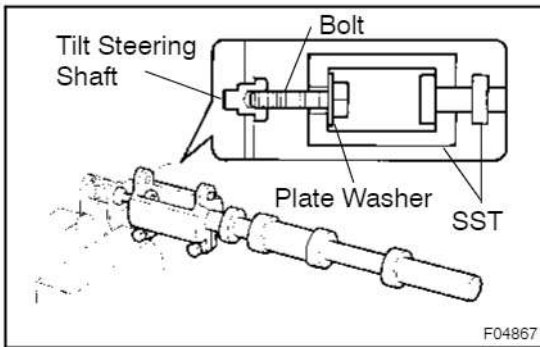
**10. REMOVE ADJUSTING NUT NO. 1**

- (a) Set SST, a plate washer (36 mm outer diameter) and bolt (6 mm normal diameter, 1.0 mm pitch, 50 mm length), as shown in the illustration.

SST 09910-00015 (09911-00011, 09912-00010)

Reference:

Plate washer 90201-10201

Bolt 91111-51050

- (b) Remove the 2 tilt steering shafts by using the sliding hammer on SST.
- (c) Remove the 2 support stopper bolt bushings from the adjusting nut No. 1.

11. REMOVE POWER TELESCOPIC MOTOR

- (a) Remove the 2 bolts and power telescopic motor.
- (b) Remove the telescopic steering column cable.

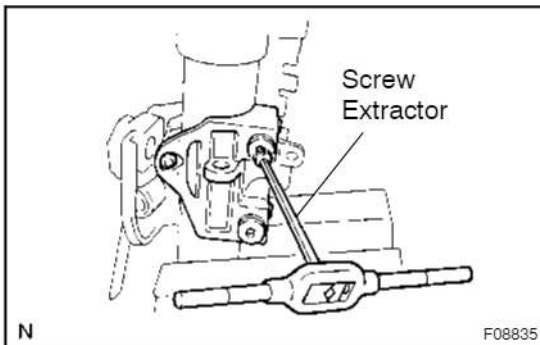
**12. REMOVE COLUMN UPPER BRACKET AND COLUMN UPPER CLAMP**

- (a) Remove column tube stopper.
- (b) Using a centering punch, mark the center of the 2 tapered-head bolts.
- (c) Using a 3 - 4 mm (0.12 - 0.16 in.) drill, drill into the 2 bolts.
- (d) Using a screw extractor, remove the 2 bolts, column upper bracket and column upper clamp.
- (e) Using a hexagon wrench, remove the 2 telescopic lever lock bolts.
- (f) Remove the 2 telescopic steering wedge lock springs and 2 steering lock wedges.

13. REMOVE COLUMN TUBE SUPPORT

- (a) Remove the bolt.
- (b) Remove the tube support with tube attachment.
- (c) Remove the tube attachment from the tube support.

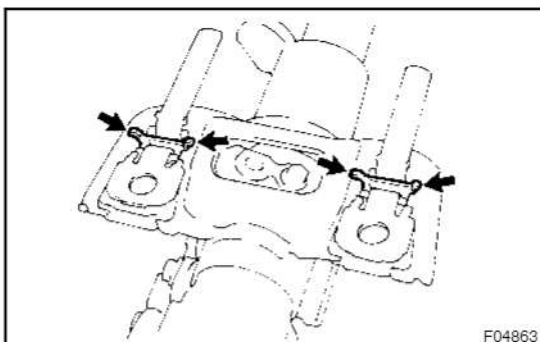
**14. REMOVE 2 ENERGY ABSORBING PLATES**

- (a) Using pliers, remove the 2 energy absorbing clips.
- (b) Remove the 2 energy absorbing plates and energy absorbing guides.

15. REMOVE TELESCOPIC STEERING SLIDER SUPPORT

Remove the 2 bolts and telescopic steering slider support.

16. REMOVE TELESCOPIC STEERING BUSHING**17. REMOVE TELESCOPIC STEERING SLIDER****18. REMOVE STEERING COLUMN BRACKET SPACER**

19. REMOVE TELESCOPIC STEERING SCREW

Remove the nut, 4 energy absorber cushions, 2 bearings and telescopic steering screw.

20. REMOVE COLUMN UPPER TUBE SUB-ASSEMBLY WITH MAIN SHAFT ASSEMBLY

- (a) Using a screwdriver, remove the lower side snap ring from the main shaft assembly.
- (b) Using a hexagon wrench, remove the 2 tilt steering bolts and column upper tube sub-assembly with the main shaft assembly.
- (c) Remove the column upper tube assembly from the break away bracket.
- (d) Remove the 2 support stopper bolt bushings from the column upper tube assembly.
- (e) Remove the 3 bushings from the break away bracket.

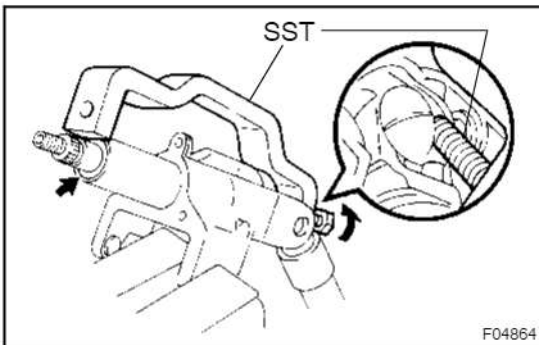
**21. REMOVE MAIN SHAFT ASSEMBLY**

- (a) Using SST, compress the compression spring.
SST 09950-40011 (09958-04010)

NOTICE:

Do not bend the universal joint of the shaft assembly more than 20°.

- (b) Using a snap ring expander, remove the upper side snap ring.
- (c) Remove the main shaft assembly from the column upper tube sub-assembly.
- (d) Remove the compression spring and bearing thrust collar from the main shaft assembly.

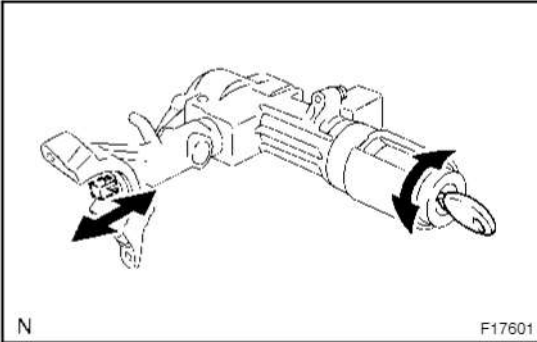

INSPECTION

NOTICE:

When using a vise, do not overtighten it.

1. INSPECT STEERING LOCK OPERATION

Check that the steering lock mechanism operates properly.

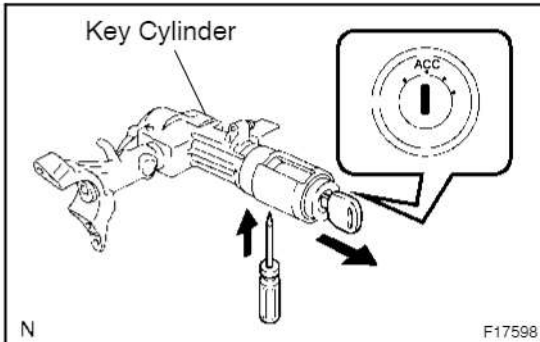

2. IF NECESSARY, REPLACE KEY CYLINDER

- (a) Place the ignition key at the ACC position.
- (b) Using a screwdriver, push down the stop pin of the cylinder, and pull out the key cylinder.
- (c) Install a new cylinder.

HINT:

Make sure the key is at the ACC position.

3. INSPECT IGNITION SWITCH

(See Pub. No. RM616E on page BE-20)

4. IF NECESSARY, REPLACE IGNITION SWITCH

- (a) Remove the 2 screws.
- (b) Install a new switch with the 2 screws.

5. INSPECT KEY UNLOCK WARNING SWITCH

(See Pub. No. RM616E on page BE-20)

6. IF NECESSARY, REPLACE KEY UNLOCK WARNING SWITCH

- (a) Slide out the switch.
- (b) Slide in a new switch.

7. IF NECESSARY, REPLACE KEY INTERLOCK SOLENOID

- (a) Remove the 2 screws.
- (b) Install a new solenoid with the 2 screws.

8. INSPECT TRANSPONDER KEY COIL

9. IF NECESSARY, REPLACE TRANSPONDER KEY COIL

10. IF NECESSARY, REPLACE TRANSPONDER KEY AMPLIFIER

- (a) Remove the 2 screws.
- (b) Install a new key amplifier with the 2 screws.

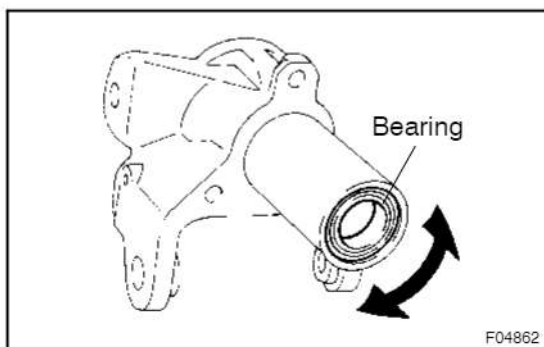
**11. INSPECT BEARING**

- (a) Check the bearing rotation condition and check for abnormal noise.
If the bearing is worn or damaged, replace the column upper tube.
- (b) Coat the bearing with molybdenum disulfide lithium base grease.

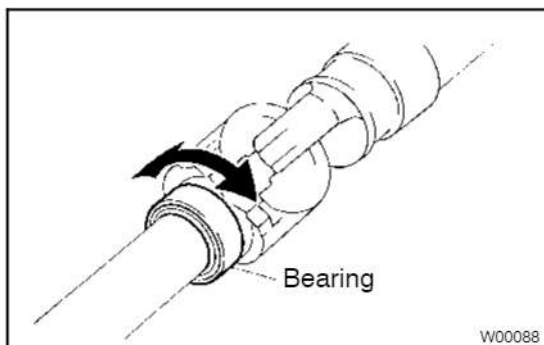
**12. INSPECT BEARING**

- (a) Check the bearing rotation condition of the main shaft assembly and check for abnormal noise.
If necessary, replace bearing.
- (b) Coat the bearing with molybdenum disulfide lithium base grease.

REASSEMBLY

NOTICE:

When using a vise, do not over tighten it.

1. **COAT WITH MOLYBDENUM DISULFIDE LITHIUM BASE GREASE**
(See page SR-3)

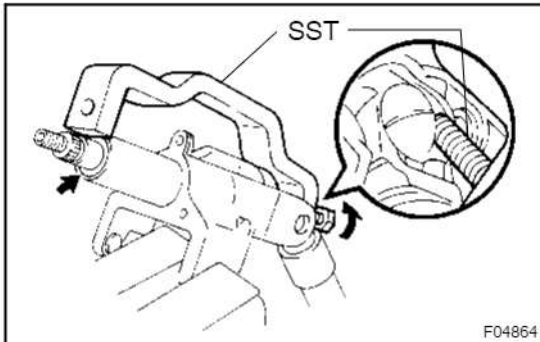

2. **INSTALL MAIN SHAFT ASSEMBLY**

- (a) Install the bearing thrust collar and compression spring to the main shaft assembly.
- (b) Install the main shaft assembly to the column upper tube sub-assembly.
- (c) Using SST, compress the compression spring.
SST 09950-40011 (09958-04010)

NOTICE:

Do not bend the universal joint of the shaft more than 20°.

- (d) Using a snap ring expander, install a new snap ring to the shaft.

3. **INSTALL COLUMN UPPER TUBE SUB-ASSEMBLY WITH MAIN SHAFT ASSEMBLY**

- (a) Install the 3 bushings to the break away bracket.
- (b) Install 2 new support stopper bolt bushings to the column upper tube assembly.
- (c) Install the column upper tube assembly to the break away bracket.
- (d) Install the column upper tube sub-assembly with the main shaft assembly to the break away bracket.
- (e) Using a hexagon wrench, install the 2 tilt steering bolts.

Torque: 20 N·m (210 kgf·cm, 15 ft·lbf)

- (f) Install a new snap ring.

4. **INSTALL TELESCOPIC STEERING SCREW**

- (a) Install the 4 energy absorber cushions, 2 bearings and telescopic steering screw.
- (b) Install the nut.

Torque: 0.8 N·m (8.2 kgf·cm, 7.1 in·lbf)

- (c) Using a punch, stake the nut.

5. **INSTALL STEERING COLUMN BRACKET SPACER**

6. **INSTALL TELESCOPIC STEERING SLIDER**

7. **INSTALL TELESCOPIC STEERING BUSHING**

8. **INSTALL TELESCOPIC STEERING SLIDER SUPPORT**

Install the telescopic steering slider support with the 2 bolts.

Torque: 11 N·m (110 kgf·cm, 8 ft·lbf)

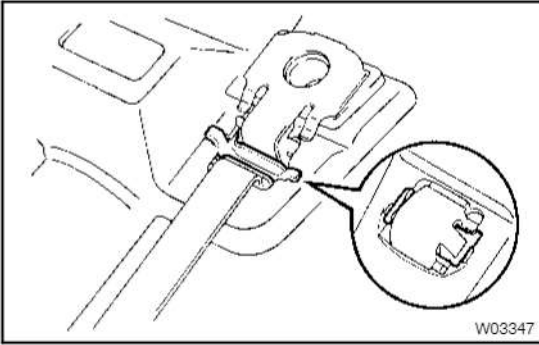

9. INSTALL 2 ENERGY ABSORBING GUIDES, PLATES AND CLIPS

- (a) Install 2 new energy absorbing guides and new absorbing plates.
- (b) Install 2 new energy absorbing clips.

10. INSTALL COLUMN TUBE SUPPORT

- (a) Install the tube attachment to the tube support.
- (b) Install the column tube support with the bolt.

Torque: 15 N·m (150 kgf·cm, 11 ft·lbf)

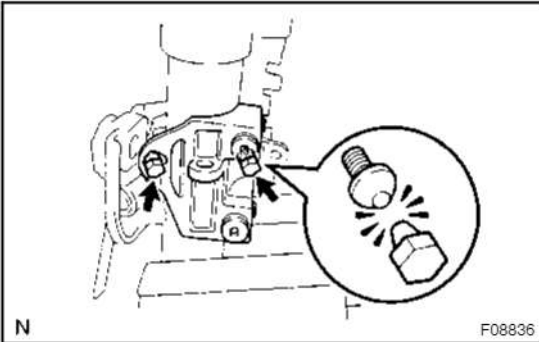

11. INSTALL COLUMN UPPER BRACKET AND COLUMN UPPER CLAMP

- (a) Install the 2 telescopic steering wedge lock springs and 2 steering lock wedges.
- (b) Using a hexagon wrench, install the 2 telescopic lever lock bolts.

Torque: 10 N·m (100 kgf·cm, 7 ft·lbf)

- (c) Install and tighten the 2 new tapered-head bolts until the bolt heads break off.

- (d) Install the column tube stopper.

Torque: 19 N·m (190 kgf·cm, 14 ft·lbf)

12. INSTALL POWER TELESCOPIC MOTOR

- (a) Install the telescopic steering column cable.
- (b) Install the power telescopic motor with the 2 bolts.

13. INSTALL ADJUSTING NUT NO. 1

- (a) Install 2 new support stopper bolt bushings.
- (b) Install the adjusting nut No. 1 to the power tilt motor.
- (c) Install the 2 tilt steering shafts.

14. INSTALL POWER TILT MOTOR

- (a) Install 2 new support stopper bolt bushings to the power tilt motor.
- (b) Install 2 new E-rings.
- (c) Using a hexagon wrench, install the 2 tilt steering bolts.

Torque: 20 N·m (210 kgf·cm, 15 ft·lbf)

- (d) Install the stopper No. 1 and stopper spring.

- (e) Using a hexagon wrench, install the support stopper bolt.

15. INSTALL TURN SIGNAL BRACKET

Install the turn signal bracket with the 3 bolts.

16. INSTALL STEERING COLUMN PROTECTOR NO. 1

Install the steering column protector No. 1 with the bolt.

Torque: 15 N·m (153 kgf·cm, 11 ft·lbf)

17. INSTALL CONNECTOR BRACKET

Install the connector bracket with the bolt.

18. INSTALL KEY CYLINDER LAMP ASSEMBLY AND TRANSPONDER KEY COIL

- (a) Install the transponder key coil with the key cylinder lamp assembly to the column upper bracket.
- (b) Install the screw.

19. w/o VGRS:

INSTALL NO. 2 LOWER COVER

**20. w/o VGRS:
INSTALL INTERMEDIATE SHAFT ASSEMBLY**

- (a) Install the thrust stopper.
- (b) Align the matchmarks on the intermediate shaft assembly and main shaft assembly.
- (c) Install the bolt.

Torque: 34 N·m (350 kgf·cm, 25 ft·lbf)

**21. w/o VGRS:
INSTALL NO. 2 LOWER COVER**

Install the No. 2 lower cover with the 2 nuts.

Torque: 24.5 N·m (240 kgf·cm, 17 ft·lbf)

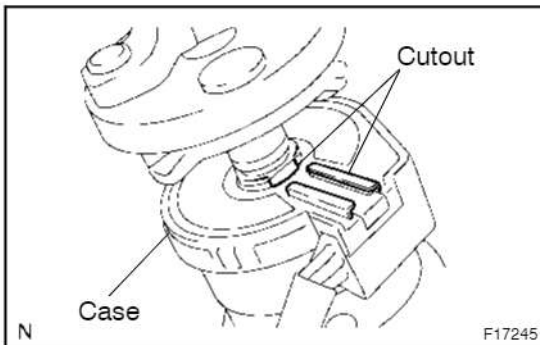

**22. w/ VGRS:
INSTALL VGRS ACTUATOR ASSEMBLY**

NOTICE:

Pull out the key from the key cylinder and lock the main shaft.

- (a) Turn the case clockwise by hand until it becomes harder to turn the cable.
- (b) Then rotate the case counterclockwise about 2.5 turns to align the cutout.

HINT:

The cable will rotate about 2.5 turns to either left or right of the center.

NOTICE:

After setting, pay attention not to rotate the VGRS actuator until the installation of the steering column.

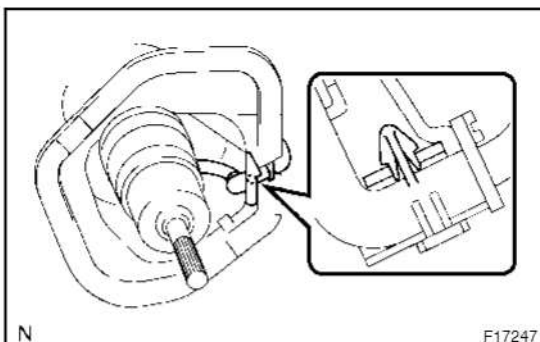

- (c) Install the boot with plate to the VGRS actuator assembly and connect wire harness clamp to the plate.
- (d) Install the thrust stopper, No. 2 lower cover and boot clamp to the main shaft assembly.
- (e) Align the matchmarks on the VGRS assembly and main shaft assembly.
- (f) Install the bolt.
- (g) Install the boot to the No. 2 lower cover and clamp.

INSTALLATION

1. **w/o VGRS:**
INSTALL NO.2 HOLE COVER, HOSE CLAMP AND HOLE COVER TO COLUMN ASSEMBLY

Temporarily tighten the hose clamp.

2. **INSTALL SLIDING YOKE**
 - (a) Check that the front wheels are facing straight ahead.
 - (b) Install the thrust stopper.
 - (c) Temporarily tighten the bolt.
3. **INSTALL STEERING COLUMN ASSEMBLY**
 - (a) Torque the 4 column assembly set nuts.
Torque: 24.5 N·m (250 kgf·cm, 18 ft·lbf)
 - (b) Connect the connector.
4. **INSTALL LOWER DUST COVER**
Install the clamp.
5. **INSTALL NO.2 INTERMEDIATE SHAFT ASSEMBLY**
Temporarily tighten the bolt.

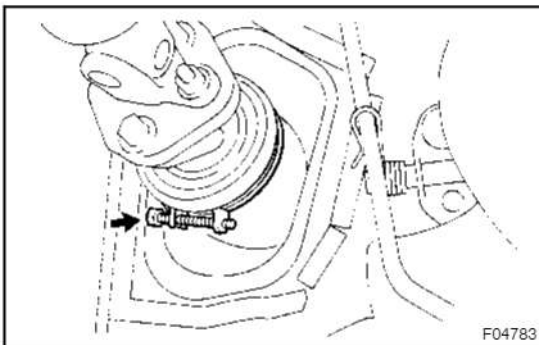

6. **w/o VGRS:**
CONNECT HOLE COVER
 - (a) Torque the 4 bolts.
Torque: 13 N·m (130 kgf·cm, 9 ft·lbf)
 - (b) Tighten the hose clamp.

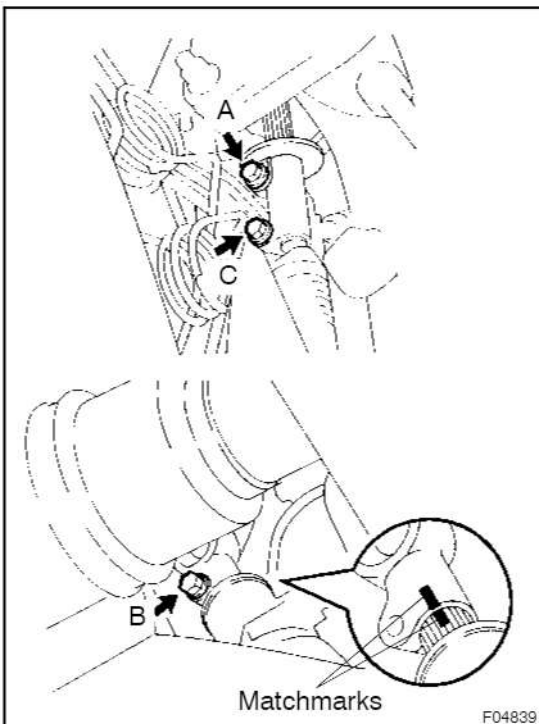

7. **CONNECT NO.2 INTERMEDIATE SHAFT ASSEMBLY**
 - (a) Align the matchmarks on the intermediate shaft and control valve shaft.
 - (b) Torque the bolt C.
Torque: 34 N·m (350 kgf·cm, 25 ft·lbf)
 - (c) Torque the bolt B.
Torque: 34 N·m (350 kgf·cm, 25 ft·lbf)
 - (d) Torque the bolt A.
Torque: 34 N·m (350 kgf·cm, 25 ft·lbf)
8. **INSTALL NO.2 HEATER TO REGISTER DUCT**
Tighten the screw.
9. **INSTALL LOWER NO.1 PANEL**
 - (a) Connect the connector.
 - (b) Tighten the pad set screw.
 - (c) Connect the fuel lid release lever with the 2 screws.
 - (d) Connect the hood lock release lever with the 2 screws.
10. **INSTALL CLUSTER FINISH PANEL**
Connect the connector.
11. **INSTALL COWL TRIM**
Install the clip.

12. **INSTALL SCUFF PLATE**
13. **INSTALL SPIRAL CABLE**
14. **INSTALL COMBINATION SWITCH WITH SPIRAL CABLE**
 - (a) Tighten the 3 screws.
 - (b) Connect the airbag connector.
 - (c) Connect the 3 connectors.
 - (d) w/ Power tilt and power telescopic steering column:
Connect the 5 connectors.
15. **INSTALL COLUMN UPPER AND LOWER COVERS**
Tighten the 3 screws to the lower cover.

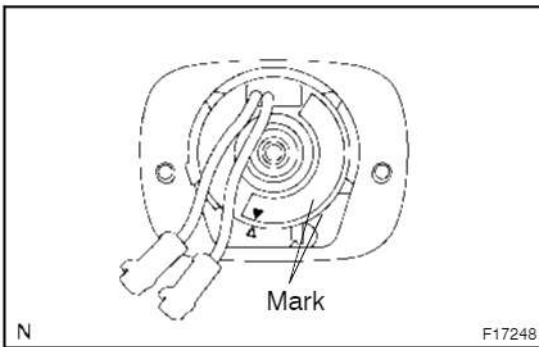

16. **CENTER SPIRAL CABLE**
 - (a) Check that the front wheels are facing straight ahead.
 - (b) Turn the cable counterclockwise by hand until it becomes harder to turn.
 - (c) Then rotate the cable clockwise about 2.5 turns to align the marks.

HINT:

The cable will rotate about 2.5 turns to either left or right of the center.

17. **INSTALL STEERING WHEEL**
 - (a) Align the matchmarks on the wheel and main shaft.
 - (b) Torque the wheel set nut.
Torque: 34 N·m (350 kgf·cm, 25 ft·lbf)
 - (c) w/ Airbag:
Connect the connector.

18. INSTALL STEERING WHEEL PAD**NOTICE:**

- **Make sure the wheel pad is installed to the specified torque.**
- **If the wheel pad has been dropped, or there are cracks, dents or other defects in the case or connector, replace the wheel pad with a new one.**
- **When installing the wheel pad, take care that the wirings do not interfere with other parts and are not pinched between other parts.**

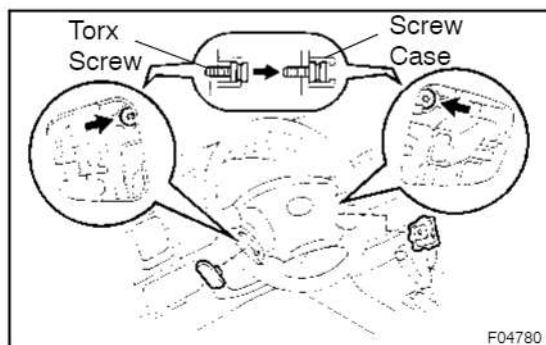

- (a) Connect the connector.
 - (b) Connect the airbag connector.
 - (c) Install the pad after confirming that the circumference groove of the torx screw is caught on the screw case.
 - (d) Using a torx socket wrench, torque the 2 screws.
Torque: 8.8 N·m (90 kgf·cm, 78 in·lbf)
 - (e) Install the steering wheel lower No.2 and No.3 covers.
- 19. CHECK AND ADJUST STEERING WHEEL CENTER POINT (See page DI-91)**
- 20. PERFORM STEERING CENTER POINT CALIBRATION (See page DI-91)**

POWER STEERING GEAR (Independent Front Suspension) COMPONENTS

SF00J-02

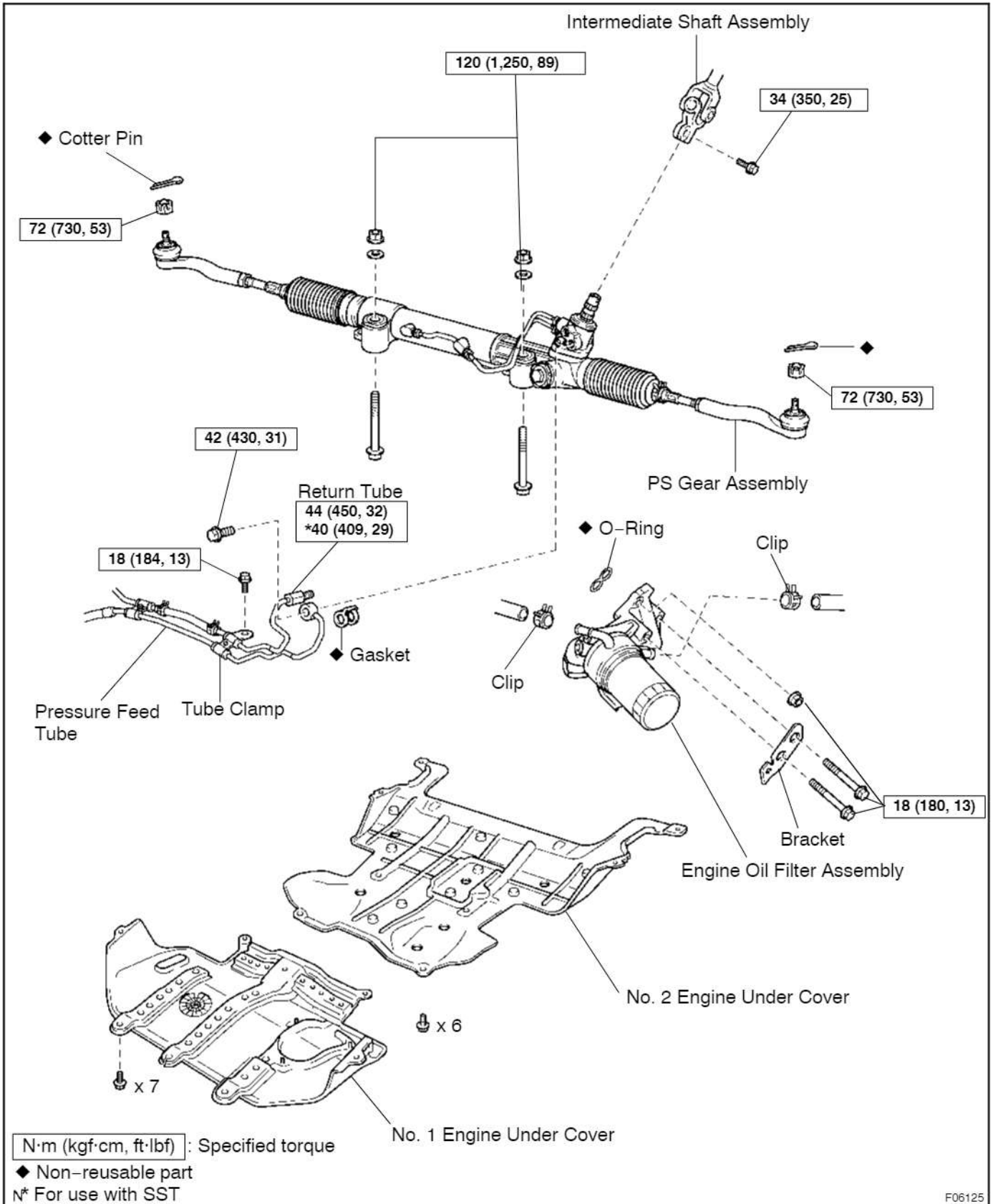

cardiagn.com

F06125

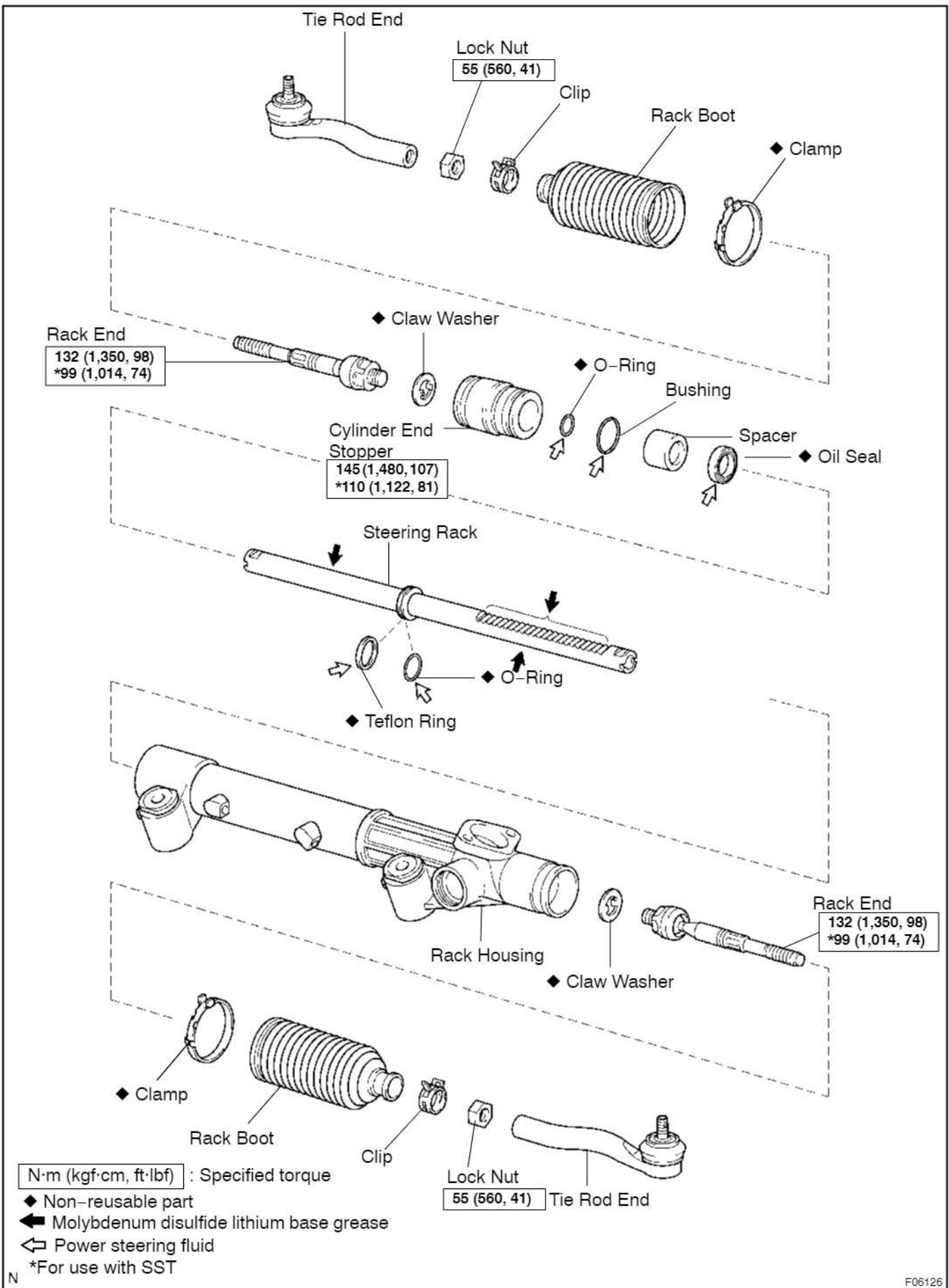

cardiagn.com

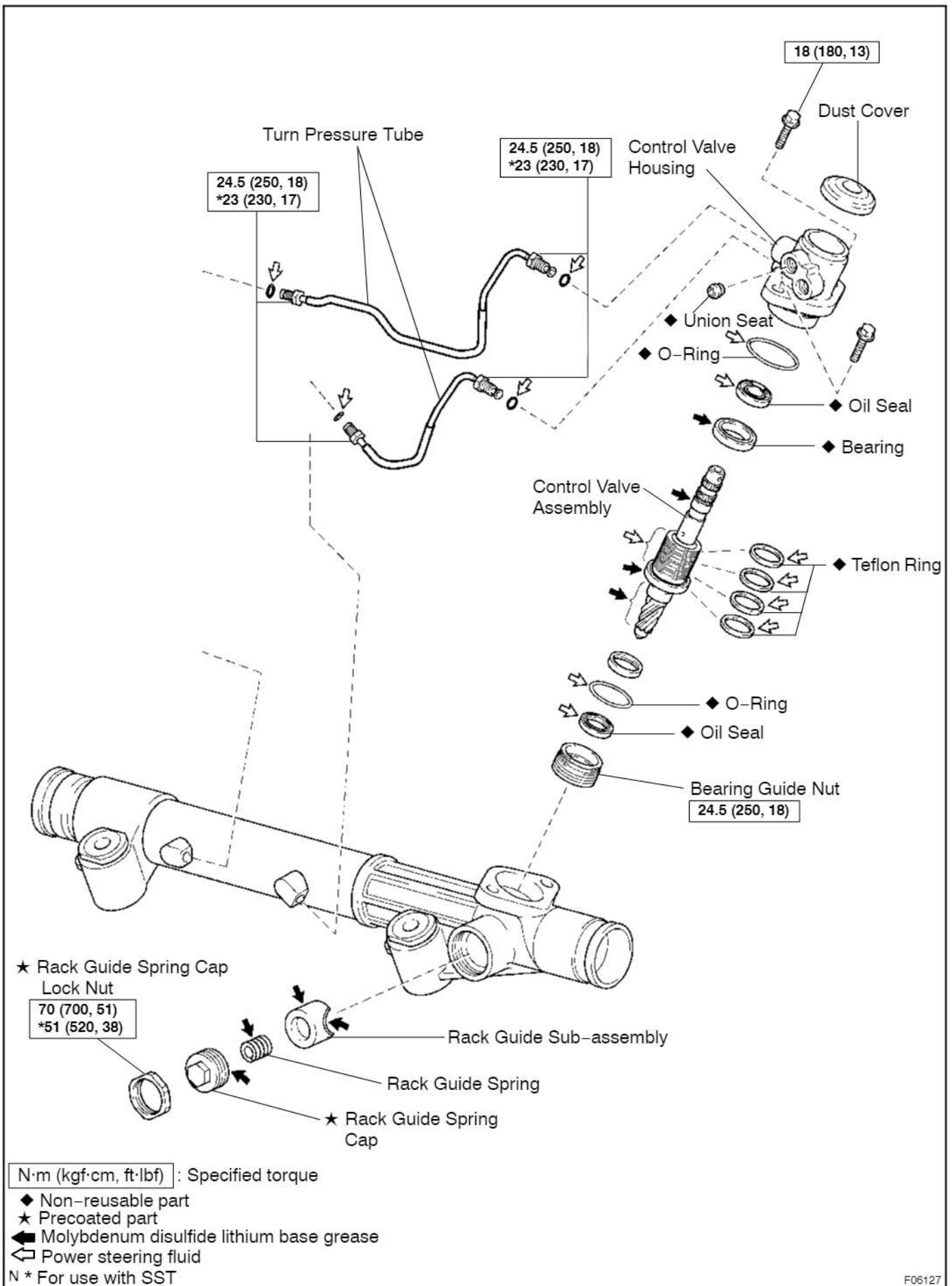

cardiagn.com

REMOVAL

NOTICE:

Remove the steering wheel assembly before the steering gear removal, because there is possibility of breaking of the spiral cable.

1. PLACE FRONT WHEELS FACING STRAIGHT AHEAD
2. REMOVE STEERING WHEEL PAD
(See page SR-5)
3. REMOVE STEERING WHEEL (See page SR-5)
4. REMOVE NO. 1 ENGINE UNDER COVER

Remove the 7 bolts.

5. REMOVE NO. 2 ENGINE UNDER COVER

Remove the 6 bolts.

6. DISCONNECT RH AND LH TIE ROD ENDS
(See Pub. No. RM616E, page SA-34)

7. REMOVE ENGINE OIL FILTER ASSEMBLY

- (a) Disconnect the 2 clips and hoses.
- (b) Remove the 2 bolts and nut with the bracket.
- (c) Remove the O-ring.

8. DISCONNECT NO. 2 INTERMEDIATE SHAFT ASSEMBLY (See page SR-5)

HINT:

Turn the steering wheel fully to the right side.

9. DISCONNECT PRESSURE FEED TUBE

Remove the union bolt, gasket and disconnect the pressure feed tube.

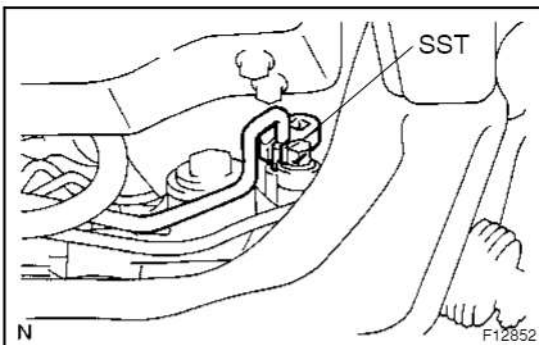

10. DISCONNECT RETURN TUBE

Using SST, disconnect the tube.

SST 09023-38400

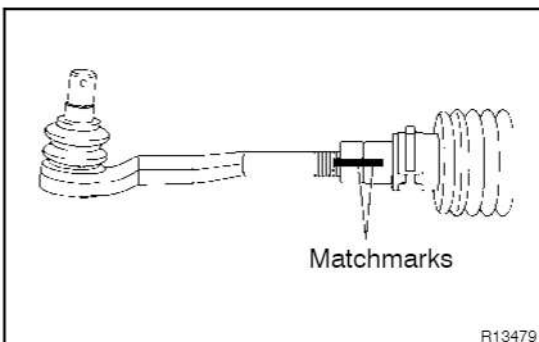

11. REMOVE RH AND LH TIE ROD ENDS AND LOCK NUTS

- (a) Place matchmarks on the tie rod end and rack end.
- (b) Loosen the lock nut, and remove the tie rod end and lock nut.
- (c) Employ the same manner described above to the other side.

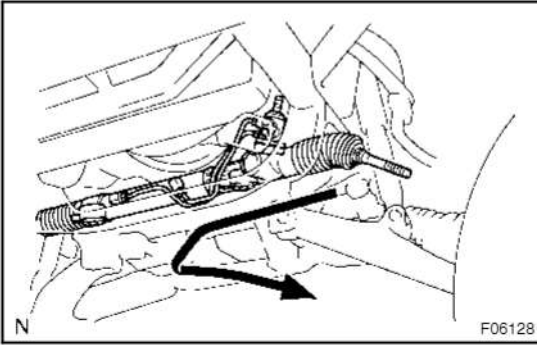

12. REMOVE PS GEAR ASSEMBLY

Remove the 2 gear assembly set bolts, nuts and washers.

HINT:

Slide the gear assembly to the right side, pull out the left side of the gear assembly from the member.

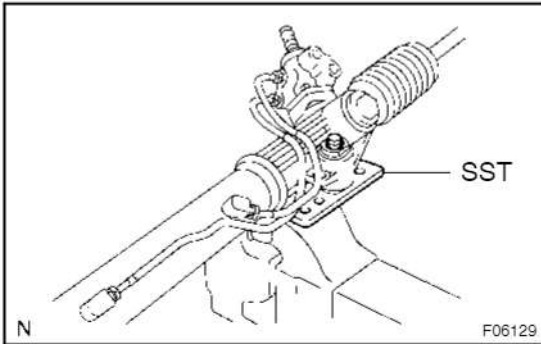

DISASSEMBLY

NOTICE:

When using a vise, do not overtighten it.

1. SECURE PS GEAR ASSEMBLY IN VISE

Using SST, secure the gear assembly in a vise, as shown in the illustration.

SST 09630-00014 (09631-00142)

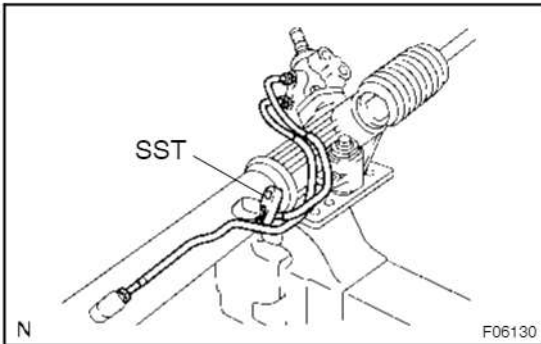

2. REMOVE 2 TURN PRESSURE TUBES

Using SST, remove the tube.

SST 09023-38200

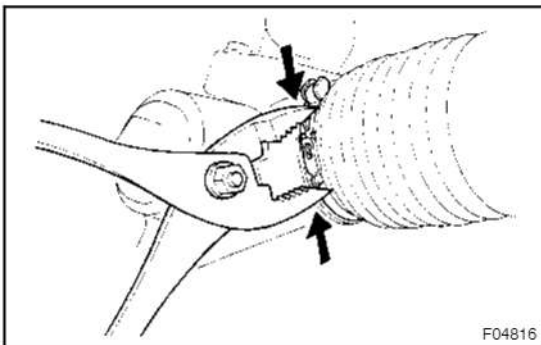

3. REMOVE RH AND LH CLIPS, RACK BOOTS AND CLAMPS

(a) Using pliers, loosen the clamp, as shown in the illustration.

NOTICE:

Be careful not to damage the boot.

(b) Remove the clip, rack boot and clamp.

(c) Employ the same manner described above to the other side.

HINT:

Mark the RH and LH rack boots.

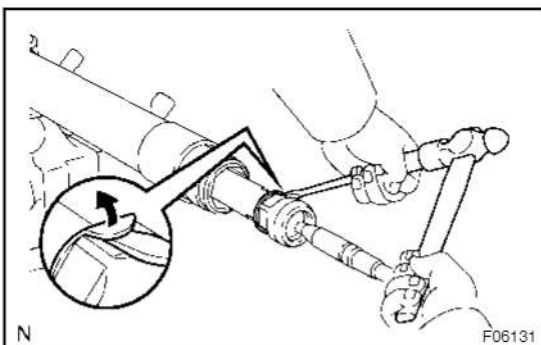

4. REMOVE RH AND LH RACK ENDS AND CLAW WASHERS

(a) Using a screwdriver and hammer, stake back the washer.

NOTICE:

Avoid and impact to the steering rack.

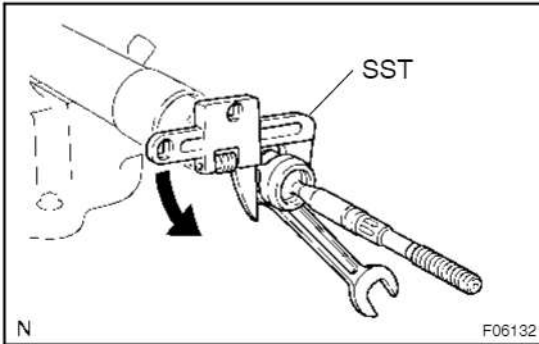

- (b) Using a spanner to hold the steering rack steady, and using SST, remove the rack end.

SST 09922-10010

NOTICE:

Use SST 09922-10010 in the direction shown in the illustration.

- (c) Remove the claw washer.
 (d) Employ the same manner described above to the other side.

HINT:

Mark the RH and LH rack ends.

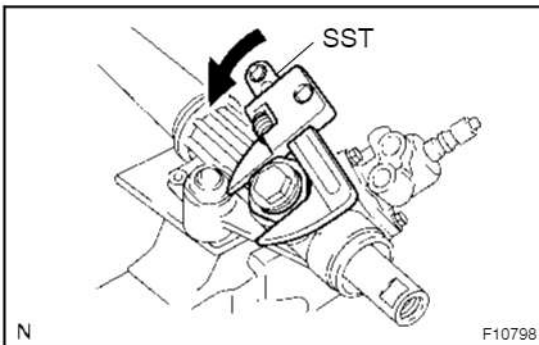

5. REMOVE RACK GUIDE SPRING CAP LOCK NUT

Using SST, remove the nut.

SST 09922-10010

NOTICE:

Use SST 09922-10010 in the direction shown in the illustration.

- 6. REMOVE RACK GUIDE SPRING CAP**
7. REMOVE RACK GUIDE SPRING AND RACK GUIDE SUB-ASSEMBLY
8. REMOVE DUST COVER
9. REMOVE CONTROL VALVE HOUSING WITH CONTROL VALVE ASSEMBLY

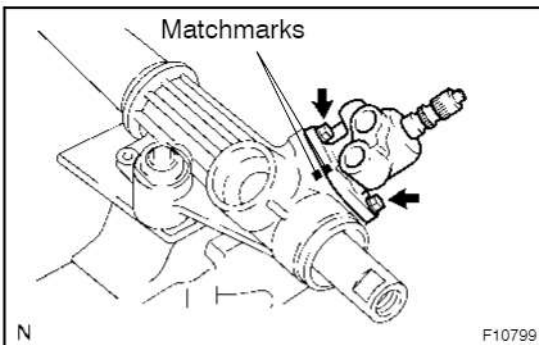

- (a) Place matchmarks on the valve housing and rack housing.
 (b) Remove the 2 bolts.
 (c) Pull out the control valve assembly with the valve housing.
 (d) Remove the O-ring from the valve housing.

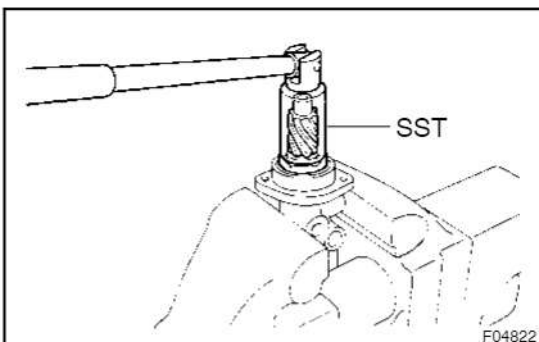

10. REMOVE CONTROL VALVE ASSEMBLY

- (a) Using SST, loosen the bearing guide nut.

SST 09631-20060

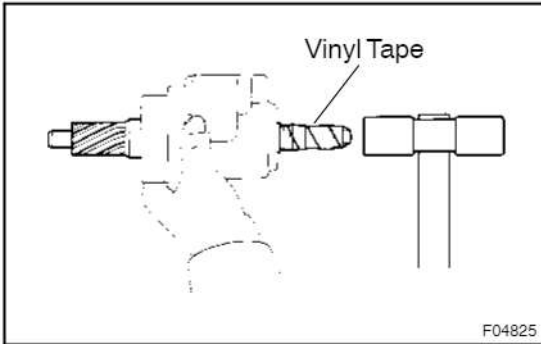

- (b) Wind vinyl tape to the control valve shaft.
- (c) Using a plastic hammer, tap out the valve assembly with the nut from the control valve housing.

NOTICE:

Be careful not to damage the oil seal lip.

- (d) Remove the nut from the valve assembly.

NOTICE:

Be careful not to damage the oil seal lip.

- (e) Remove the O-ring from the nut.

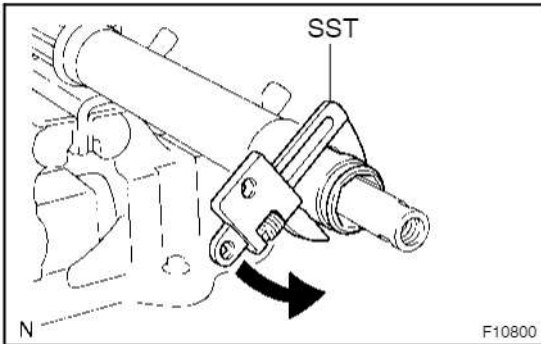

11. REMOVE CYLINDER END STOPPER AND SPACER

- (a) Using SST, remove the stopper.

SST 09922-10010

NOTICE:

Use SST 09922-10010 in the direction shown in the illustration.

- (b) Remove the O-ring from the stopper.

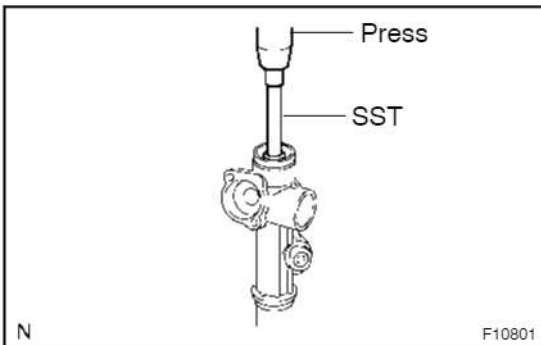

12. REMOVE STEERING RACK AND OIL SEAL

- (a) Using SST, press out the rack and oil seal.

NOTICE:

Take care not to drop the rack.

SST 09950-70010 (09951-07200)

- (b) Remove the oil seal from the rack.

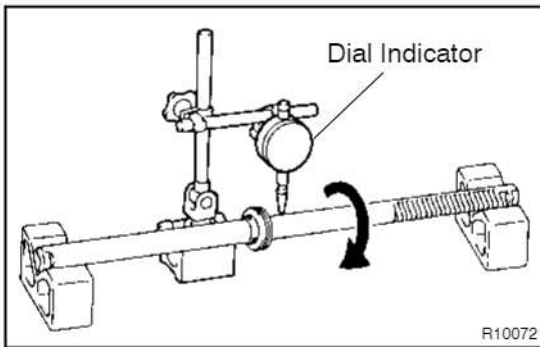

INSPECTION

1. INSPECT STEERING RACK

- (a) Using a dial indicator, check the rack for runout and for teeth wear and damage.

Maximum runout: 0.03 mm (0.0012 in.)

- (b) Check the back surface for wear and damage.

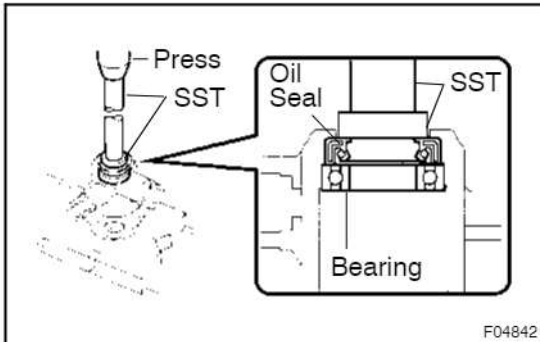

2. IF NECESSARY, REPLACE OIL SEAL AND BEARING

- (a) Using SST, press out the oil seal and bearing from the control valve housing.

SST 09950-60010 (09951-00260),
09950-70010 (09951-07150)

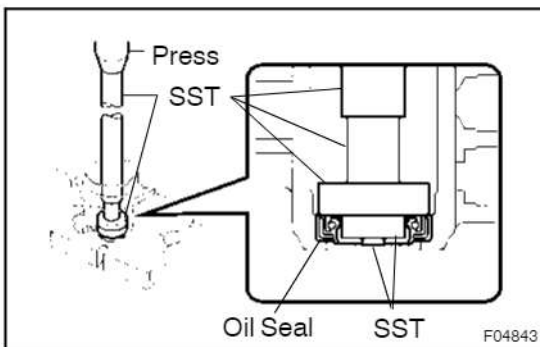

- (b) Coat a new oil seal lip with power steering fluid.

- (c) Using SST, press in the oil seal.

SST 09950-60010 (09951-00180, 09951-00330,
09952-06010), 09950-70010 (09951-07150)

NOTICE:

Make sure to install the oil seal facing the correct direction.

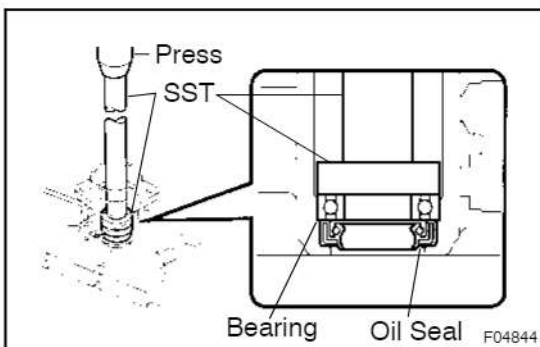

- (d) Coat a new bearing with molybdenum disulfide lithium base grease.

- (e) Using SST, press in the bearing.

SST 09950-60010 (09951-00330),
09950-70010 (09951-07150)

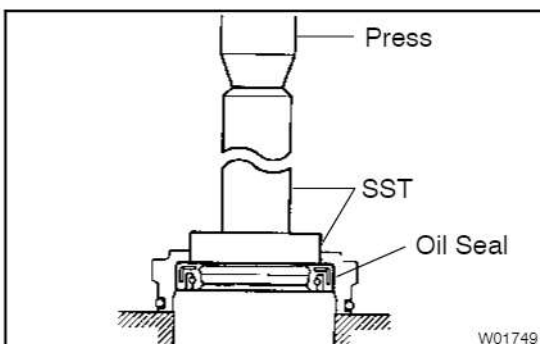

3. IF NECESSARY, REPLACE OIL SEAL

- (a) Using SST, press out the oil seal from the bearing guide nut.

SST 09950-60010 (09951-00320),
09950-70010 (09951-07100)

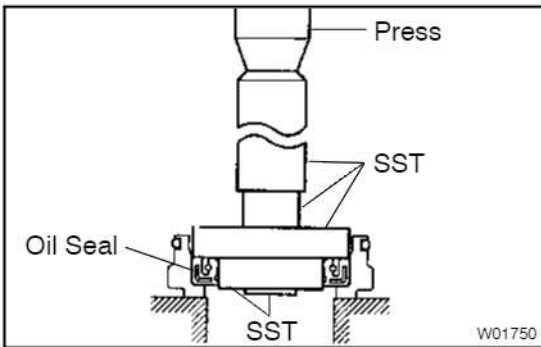

- (b) Coat a new oil seal lip with power steering fluid.
- (c) Using SST, press in the oil seal.
SST 09950-60010 (09951-00280, 09951-00360, 09952-06010), 09950-70010 (09951-07100)

NOTICE:

Make sure to install the oil seal facing the correct direction.



4. INSPECT BEARING

- (a) Check the needle roller bearing of the rack housing for pit-marks or damage.
If faulty, replace the rack housing.
- (b) Coat the inside of the bearing with molybdenum disulfide lithium base grease.

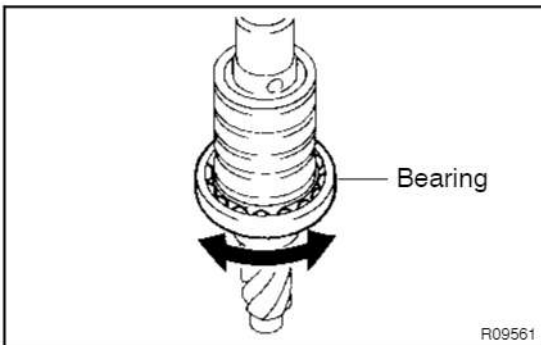

5. INSPECT BEARING

- (a) Check the bearing rotation condition and check for abnormal noise.
If the bearing is worn or damaged, replace the control valve assembly.
- (b) Coat the bearing with molybdenum disulfide lithium base grease.

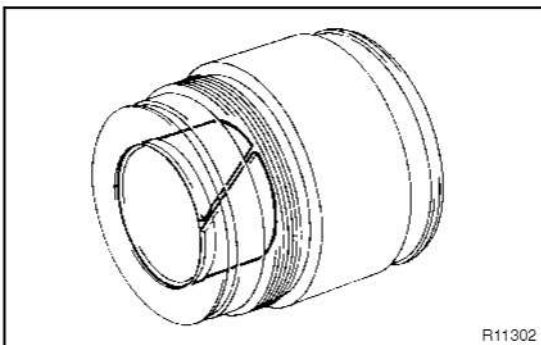

6. INSPECT BUSHING

- (a) Check the inside of the bushing of the cylinder end stopper for cracks.
If faulty, replace the bushing.
- (b) Apply molybdenum disulfide lithium base grease to the inside of the bushing.

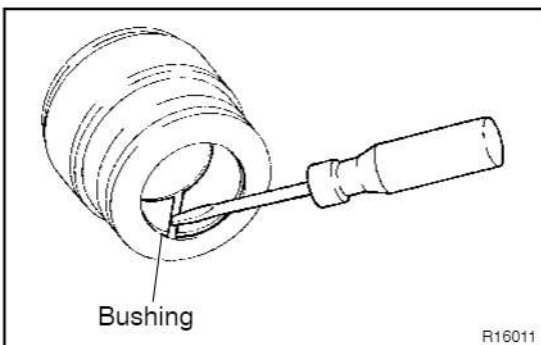

7. IF NECESSARY, REPLACE BUSHING

- (a) Using a screwdriver, remove the bushing from the cylinder end stopper.
- NOTICE:**
Be careful not to damage the cylinder end stopper.
- (b) Coat the inside of a new bushing with molybdenum disulfide lithium base grease.
 - (c) Install the bushing.

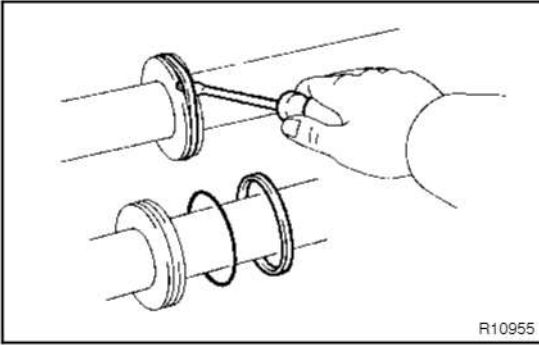

8. IF NECESSARY, REPLACE TEFLON RING AND O-RING

- (a) Using a screwdriver, remove the teflon ring and O-ring from the steering rack.

NOTICE:

Be careful not to damage the groove for the ring.

- (b) Coat a new O-ring with power steering fluid and install it.

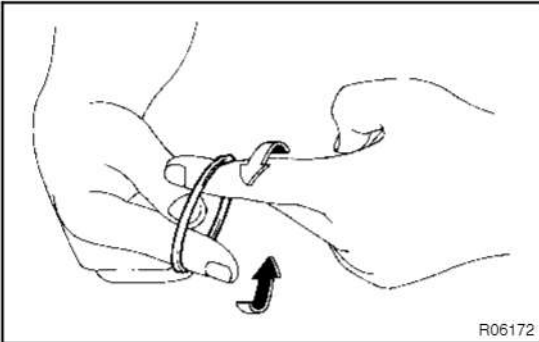

- (c) Expand a new teflon ring with your fingers.

NOTICE:

Be careful not to overexpand the ring.

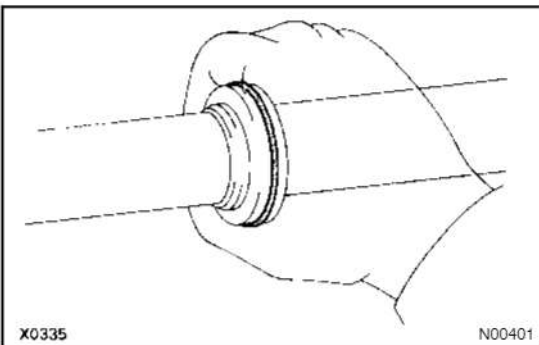

- (d) Coat the ring with power steering fluid.

- (e) Install the ring to the rack, and settle it down with your fingers.

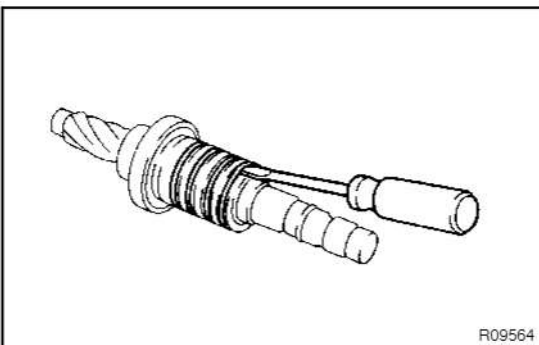

9. IF NECESSARY, REPLACE 4 TEFLON RINGS

- (a) Using a screwdriver, remove the 4 rings from the control valve assembly.

NOTICE:

Be careful not to damage the grooves for the ring.

- (b) Expand 4 new rings with your fingers.

NOTICE:

Be careful not to overexpand the ring.

- (c) Coat the rings with power steering fluid.

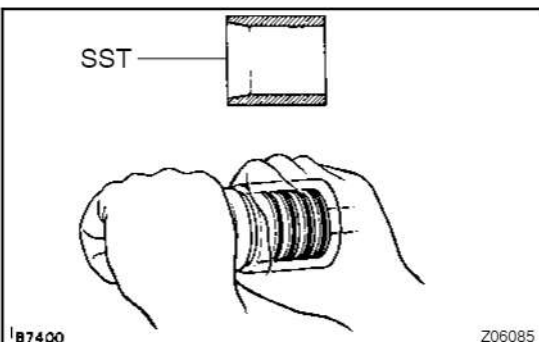

- (d) Install the rings to the control valve assembly, and settle them down with your fingers.

- (e) Carefully slide the tapered end of SST over the rings until the ring fits to the valve assembly.

SST 09631-20081

NOTICE:

Be careful not to damage the rings.

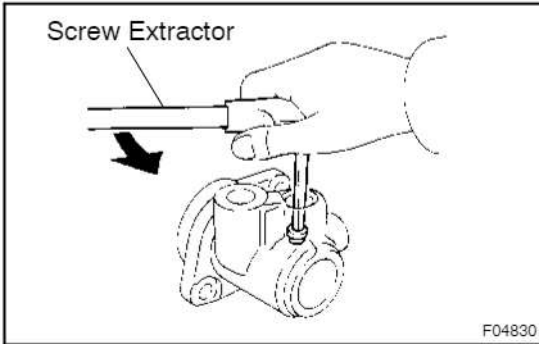

10. IF NECESSARY, REPLACE UNION SEAT

- (a) Using a screw extractor, remove the seat from the control valve housing.

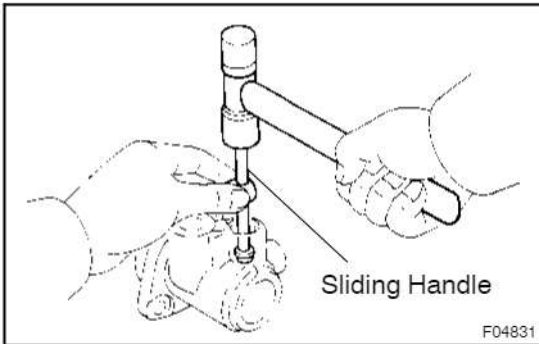

- (b) Using plastic hammer and sliding handle, lightly tap in a new seat.

NOTICE:

Before installing the union seat, remove dust sticking to the control valve housing.

REASSEMBLY

NOTICE:

When using a vise, do not overtighten it.

1. COAT PARTS INDICATED BY ARROWS WITH POWER STEERING FLUID OR MOLYBDENUM DISULFIDE LITHIUM BASE GREASE

(See page SR-20)

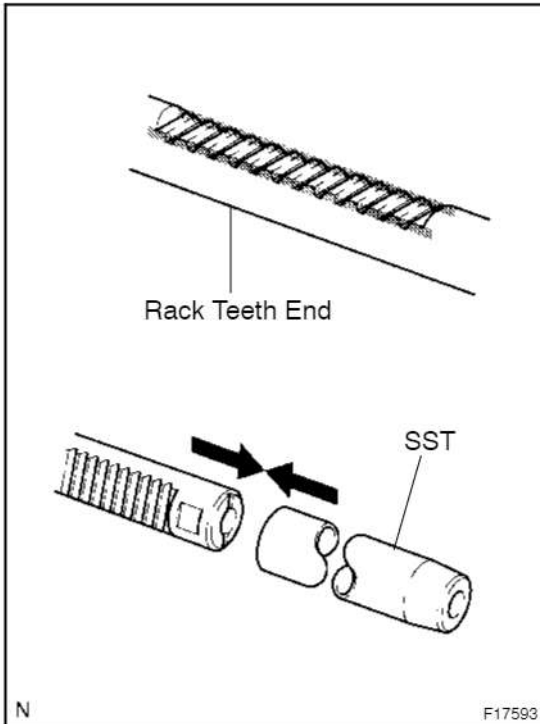

2. INSTALL STEERING RACK

- (a) Install SST to the rack.

SST 09631-00350

HINT:

If necessary, scrape the burrs off the rack teeth end and bur-nish.

- (b) Coat SST with power steering fluid.
- (c) Install the rack into the rack housing.
- (d) Remove the SST.

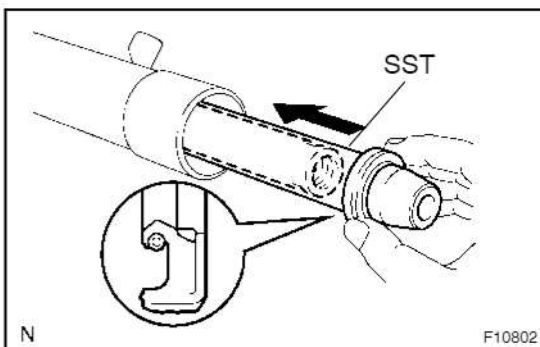

3. INSTALL OIL SEAL

- (a) Install SST to the steering rack opposite end.

SST 09631-00350

- (b) Coat SST with power steering fluid.
- (c) Coat a new oil seal lip with power steering fluid.
- (d) Install the oil seal by pushing it onto the SST without tilt-ing.

NOTICE:

Make sure to install the oil seal facing the correct direction.

- (e) Remove the SST.

4. INSTALL SPACER AND CYLINDER END STOPPER

- (a) Install the spacer.
- (b) Coat a new O-ring with power steering fluid, and install it to the stopper.
- (c) Using a wooden block and hammer, drive in the stopper until it is tightly installed.

NOTICE:

Be careful not to damage the O-ring.

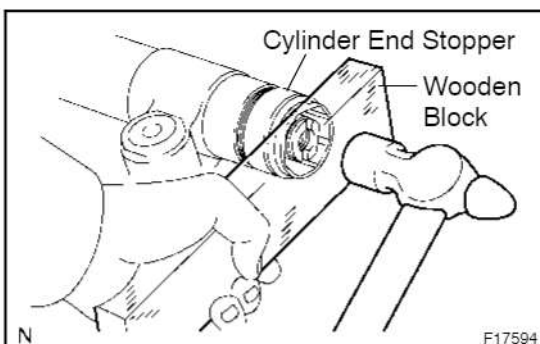

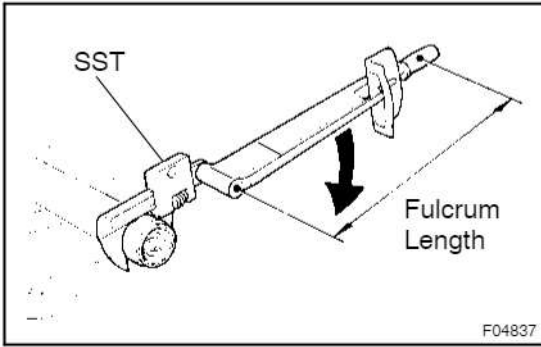

- (d) Using SST, torque the stopper.
 SST 09922-10010
Torque: 110 N·m (1,122 kgf·cm, 81 ft·lbf)

NOTICE:

Use SST 09922-10010 in the direction shown in the illustration.

HINT:

Use a torque wrench with a fulcrum length of 345 mm (13.58 in.).

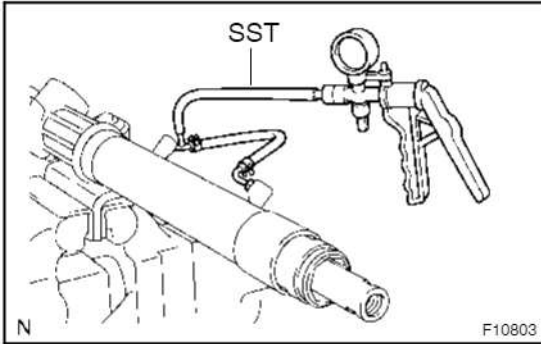

5. AIR TIGHTNESS TEST

- (a) Install SST to the unions of the rack housing.
 SST 09631-12071
 (b) Apply 53 kPa (400 mmHg, 15.75 in.Hg) of vacuum for about 30 seconds.
 (c) Check that there is no change in the vacuum.
 If there is change in the vacuum, check the installation of the oil seals.

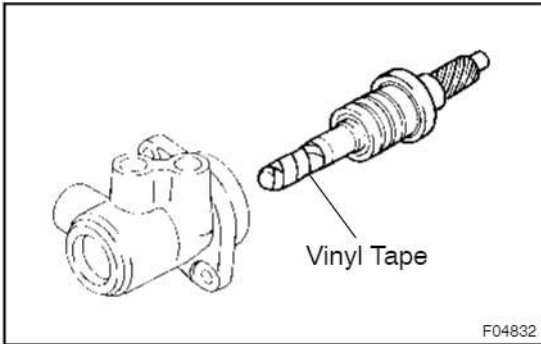

6. INSTALL CONTROL VALVE ASSEMBLY

- (a) Coat the teflon rings with power steering fluid.
 (b) To prevent oil seal lip damage, wind vinyl tape on the serrated part of the control valve shaft.
 (c) Push the valve assembly into the control valve housing.

NOTICE:

Be careful not to damage the teflon rings and oil seal lip.

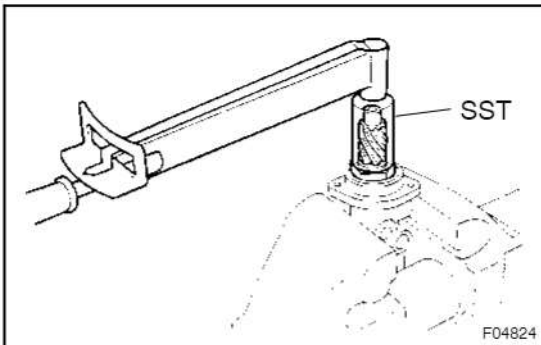

- (d) Coat a new O-ring with power steering fluid, and install it to the bearing guide nut.
 (e) Using SST, torque the nut.
 SST 09631-20060

Torque: 24.5 N·m (250 kgf·cm, 18 ft·lbf)

NOTICE:

Be careful not to damage the oil seal lip.

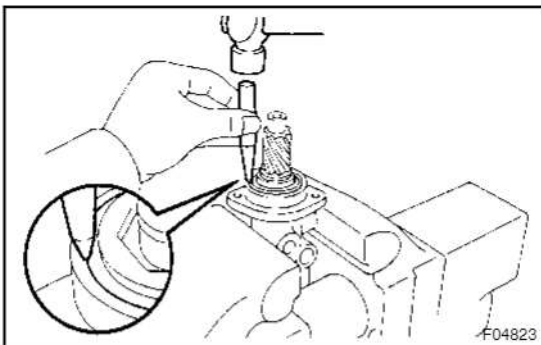

- (f) Using a punch, stake the nut.

7. INSTALL CONTROL VALVE HOUSING WITH CONTROL VALVE ASSEMBLY

- (a) Coat a new O-ring with power steering fluid, and install it to the valve housing.
- (b) Align the matchmarks on the valve housing and rack housing, and install the valve housing with the valve assembly to the rack housing.
- (c) Torque the 2 bolts.

Torque: 18 N·m (180 kgf·cm, 13 ft·lbf)

8. INSTALL DUST COVER**9. INSTALL RACK GUIDE SUB-ASSEMBLY, RACK GUIDE SPRING AND RACK GUIDE SPRING CAP**

- (a) Apply sealant to 2 or 3 threads of the cap.

Sealant:

Part No. 08833-00080, THREE BOND 1344,

LOCTITE 242 or equivalent

- (b) Temporarily install the cap.

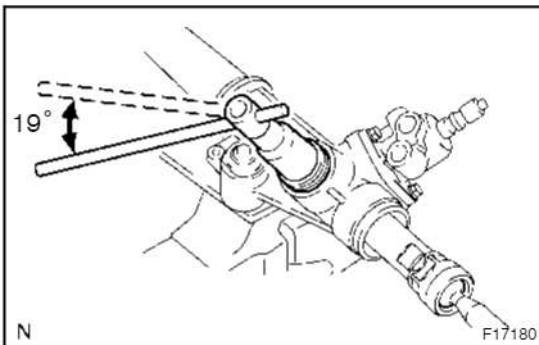
**10. ADJUST TOTAL PRELOAD**

- (a) To prevent the steering rack teeth from damaging the oil seal lip, temporarily install the RH and LH rack ends.
 - (b) Torque the rack guide spring cap.
- Torque: 25 N·m (250 kgf·cm, 18 ft·lbf)**
- (c) Return the cap 19°.

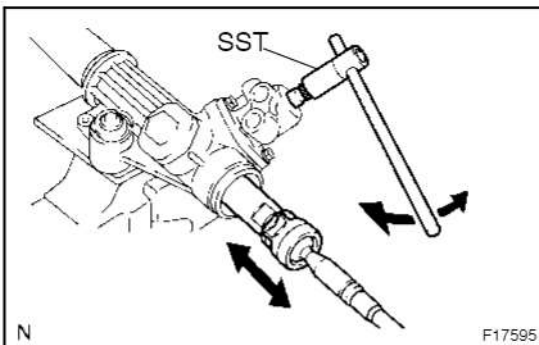

- (d) Using SST, turn the control valve shaft right and left 1 or 2 times.

SST 09616-00011

- (e) Loosen the cap until the rack guide spring is not functioning.

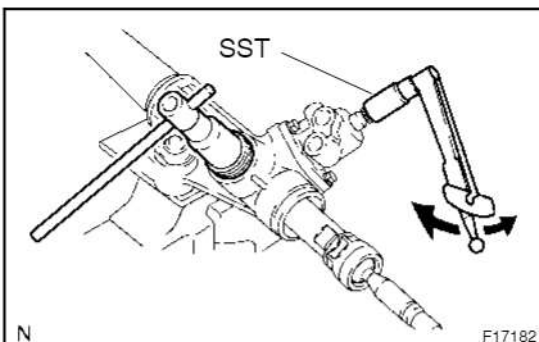

- (f) Using SST and a torque wrench, tighten the cap until the preload is within specification.

SST 09616-00011

Preload (turning):

Center Area

1.8 - 2.2 N·m (18.4 - 22.4 kgf·cm, 16.0 - 19.5 in·lbf)

End Area

1.3 - 1.7 N·m (13.3 - 17.3 kgf·cm, 11.5 - 15.0 in·lbf)

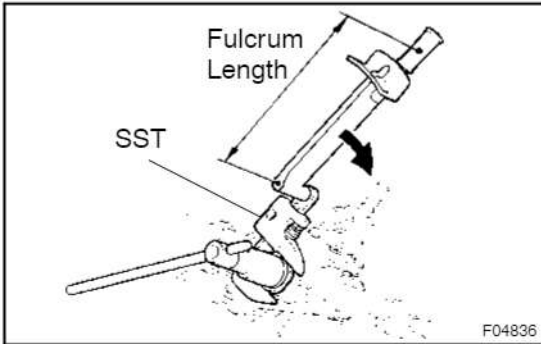

11. INSTALL RACK GUIDE SPRING CAP LOCK NUT

- (a) Apply sealant to 2 or 3 threads of the nut.
Sealant:
Part No.08833-00080, THREE BOND 1344, LOCTITE 242 or equivalent
- (b) Holding the rack guide spring cap rotating, and using SST, torque the nut.
 SST 09922-10010
Torque: 52 N·m (520 kgf·cm, 38 ft·lbf)

NOTICE:

Use SST 09922-10010 in the direction shown in the illustration.

HINT:

Use a torque wrench with a fulcrum length of 345 mm (13.58 in.).

- (c) Recheck the total preload.

Preload (turning):

Center Area

1.8 - 2.2 N·m (18.4 - 22.4 kgf·cm, 16.0 - 19.5 in·lbf)

End Area

1.3 - 1.7 N·m (13.3 - 17.3 kgf·cm, 11.5 - 15.0 in·lbf)

- (d) Remove the RH and LH rack ends.

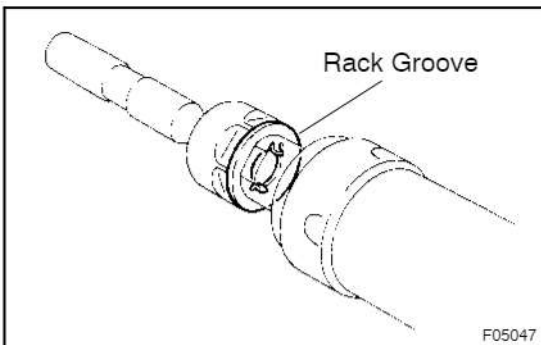

12. INSTALL RH AND LH CLAW WASHERS AND RACK ENDS

- (a) Install a new washer, and temporarily tighten the rack end.

HINT:

Align the claws of the washer with the steering rack grooves.

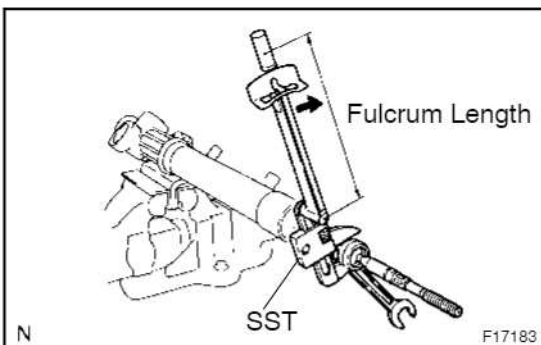

- (b) Using a spanner to hold the steering rack steady, and using SST, torque the rack end.
 SST 09922-10010

Torque: 99 N·m (1,014 kgf·cm, 74 ft·lbf)

NOTICE:

Use SST 09922-10010 in the direction shown in the illustration.

HINT:

Use a torque wrench with a fulcrum length of 345 mm (13.58 in.).

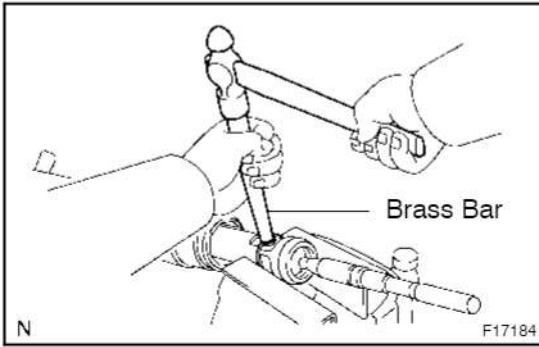

(c) Using a brass bar and hammer, stake the washer.

NOTICE:

Avoid any impact to the rack.

(d) Employ the same manner described above to the other side.

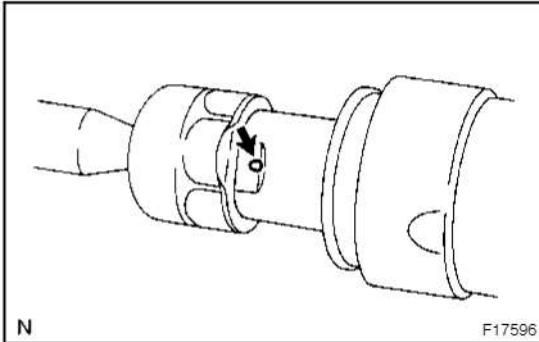

13. INSTALL RH AND LH RACK BOOTS, CLAMPS AND CLIPS

(a) Ensure that the tube hole is not clogged with grease.

HINT:

If the tube hole is clogged, the pressure inside the boot will change after it is assembled and the steering wheel is turned.

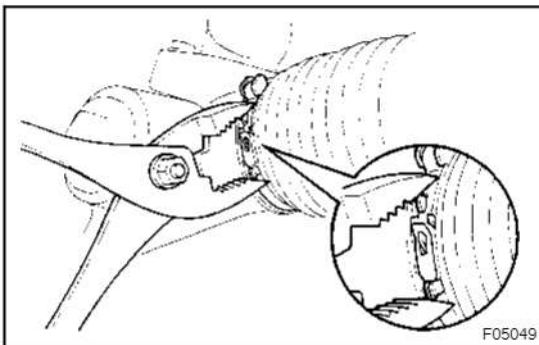

(b) Install the boot.

NOTICE:

Be careful not to damage or twist the boot.

(c) Using pliers tighten a new clamp, as shown in the illustration.

(d) Employ the same manner described above to the other side.

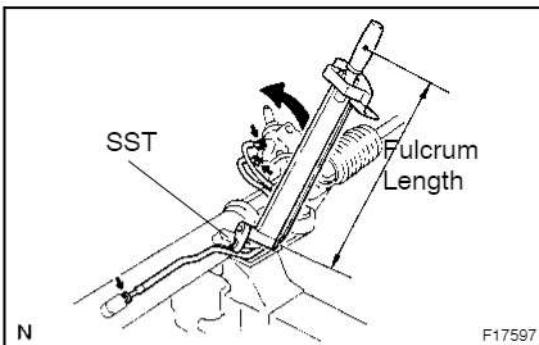

14. INSTALL 2 TURN PRESSURE TUBES

Using SST, install the tube.

SST 09023-38200

Torque: 24.5 N·m (250 kgf·cm, 18 ft·lbf)

HINT:

- Use a torque wrench with a fulcrum length of 300 mm (11.81 in.).
- This torque value is effective in case that SST is parallel to a torque wrench.

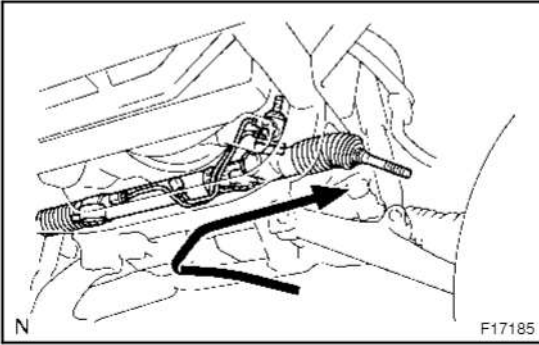

INSTALLATION

1. INSTALL PS GEAR ASSEMBLY

Torque the 2 new gear assembly set bolts, nuts and washers.

Torque: 120 N·m (1,250 kgf·cm, 89 ft·lbf)

HINT:

Slide the gear assembly to the right side, slide the gear assembly to the left side and position it.

2. INSTALL RH AND LH TIE ROD ENDS AND LOCK NUTS

(a) Screw the lock nut and tie rod end onto the rack end until the matchmarks are aligned.

(b) After adjusting toe-in, torque the nut (See Pub. No. RM616E on page SA-9).

Torque: 55 N·m (560 kgf·cm, 41 ft·lbf)

3. CONNECT TUBE CLAMP

Torque the bolt.

Torque: 18 N·m (180 kgf·cm, 13 ft·lbf)

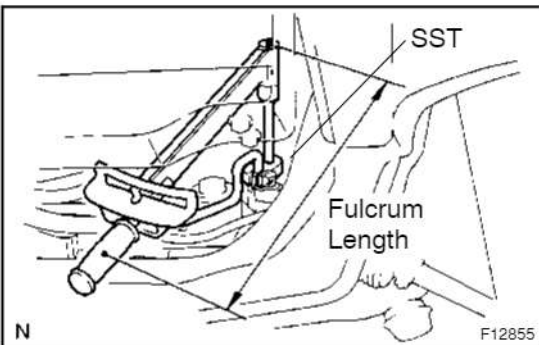

4. CONNECT RETURN TUBE

Using SST, connect the tube.

SST 09023-38400

Torque: 44 N·m (450 kgf·cm, 32 ft·lbf)

HINT:

- Use a torque wrench with a fulcrum length of 300 mm (11.81 in.).
- This torque value is effective in case that SST is parallel to a torque wrench.

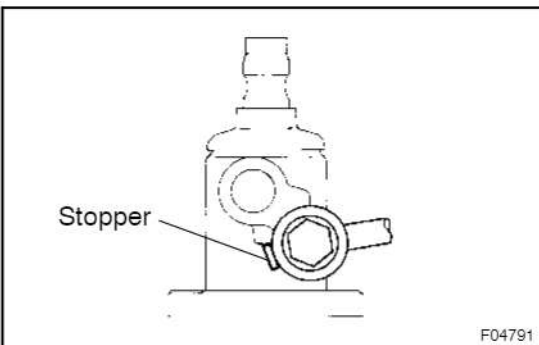

5. CONNECT PRESSURE FEED TUBE

Torque the union bolt with a new gasket.

HINT:

Make sure the stopper of the pressure feed tube touches the PS gear assembly as shown in the illustration, then torque the bolt.

Torque: 42 N·m (430 kgf·cm, 31 ft·lbf)

6. CONNECT NO. 2 INTERMEDIATE SHAFT ASSEMBLY (See page SR-17)

7. INSTALL ENGINE OIL FILTER ASSEMBLY

(a) Install a new O-ring.

(b) Torque the 2 bolts and nut with the bracket.

Torque: 18 N·m (180 kgf·cm, 13 ft·lbf)

(c) Connect the 2 clips and hoses.

8. CONNECT RH AND LH TIE ROD ENDS (See Pub. No. RM616E, page SA-38)

9. INSTALL NO. 2 ENGINE UNDER COVER

Tighten the 6 bolts.

10. INSTALL NO. 1 ENGINE UNDER COVER

Tighten the 7 bolts.

11. POSITION FRONT WHEELS FACING STRAIGHT AHEAD

HINT:

Do it with the front of the vehicle jacked up.

12. CENTER SPIRAL CABLE (See page SR-17)**13. INSTALL STEERING WHEEL**

- (a) Align the matchmarks on the wheel and steering column main shaft.
- (b) Temporarily tighten the wheel set nut.
- (c) Connect the connector.

**14. BLEED POWER STEERING SYSTEM
(See Pub. No. RM616E, page SR-4)****15. CHECK STEERING WHEEL CENTER POINT****16. TORQUE STEERING WHEEL SET NUT
Torque: 50 N·m (510 kgf·cm, 37 ft·lbf)****17. INSTALL STEERING WHEEL PAD (See page SR-17)****18. CHECK FRONT WHEEL ALIGNMENT (See Pub. No. RM616E, page SA-9)****19. PERFORM VGRS SYSTEM CALIBRATION
(See page DI-100)****20. PERFORM ZERO POINT CALIBRATION OF YAW RATE AND DECELERATION SENSORS
(See Pub. No. RM970E, page DI-185)**